

# Chapter 1. Disassembly & Assembly Guide

---

## 1-3. Disassembly & Assembly

### - Main Section -

#### MS-1 Main Section Disassembly

# Battery Pack, Dummy Card (EXP), Dummy Card (PC)

1)

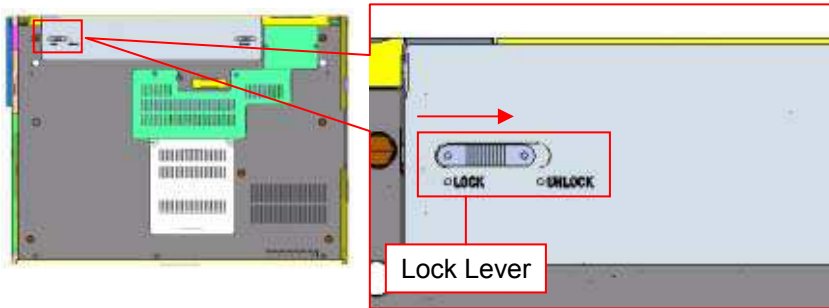

Slide the Lock Lever to the UNLOCK side.

2)

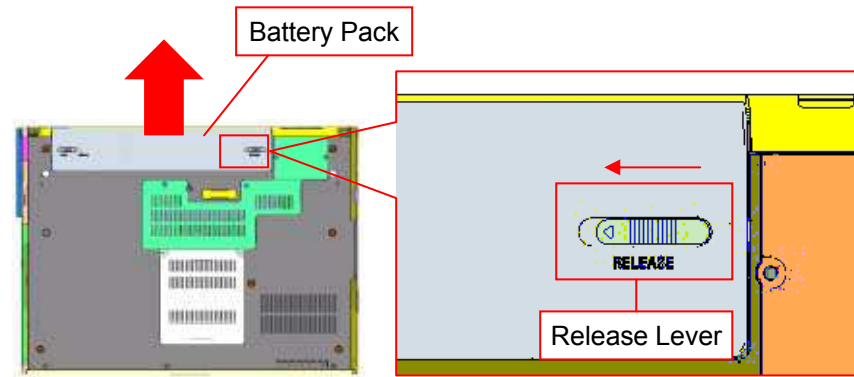

While Release Lever is slid in the left, remove the Battery Pack.

3)

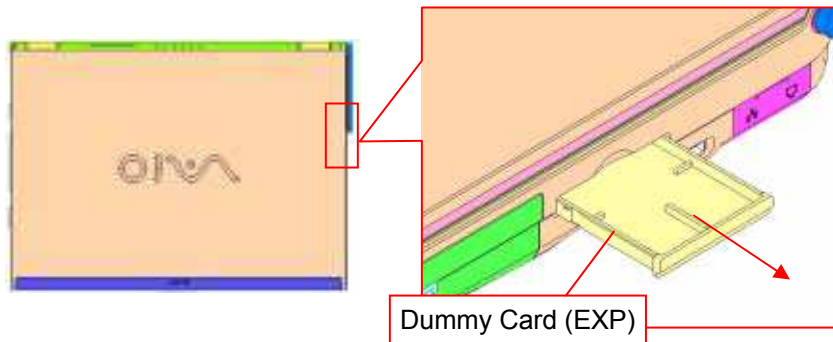

Hook the finger on the Dummy Card (EXP) and remove it.

4)

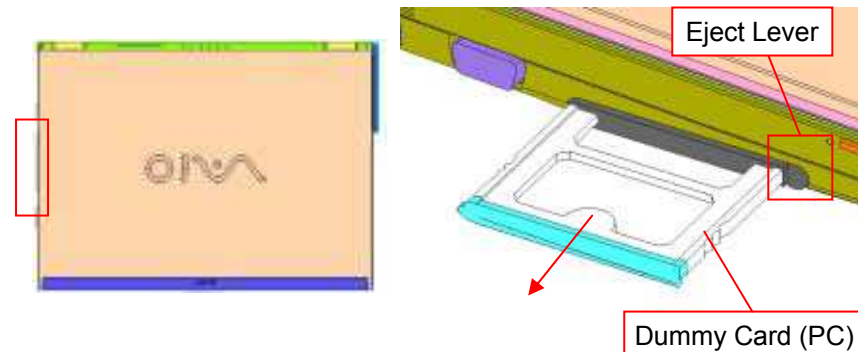

Push the Eject Lever once, and the Eject Lever pops up. Push the Eject Lever once again, and remove the Dummy Card (PC).

# WAN Antenna (Element Unit)

WAN Model

1)

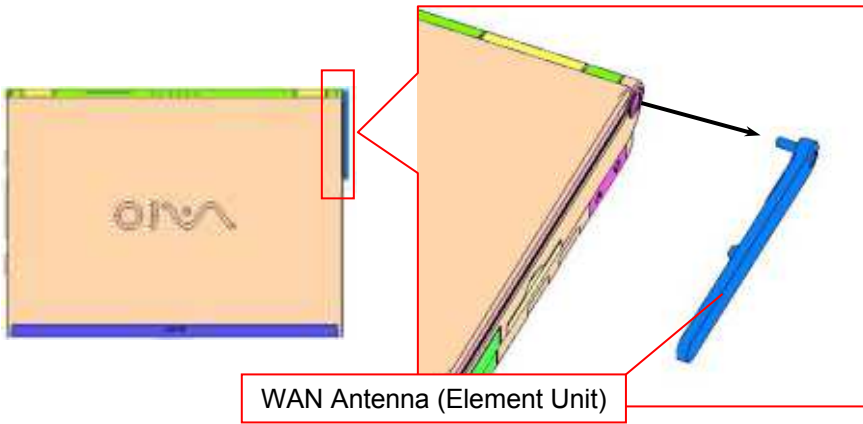

Remove the WAN Antenna (Element Unit).

# Heatsink

1)

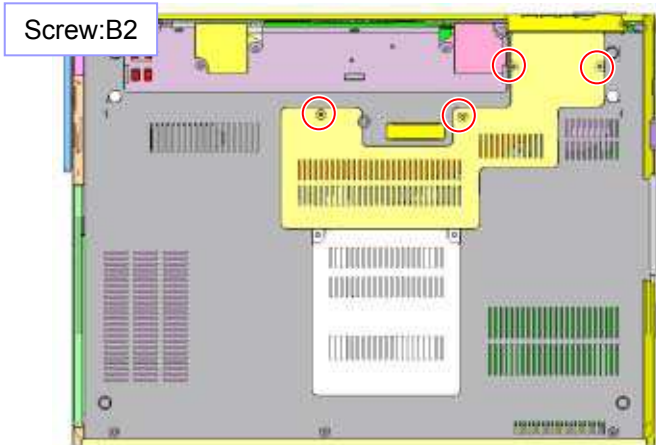

Remove the four screws.

2)

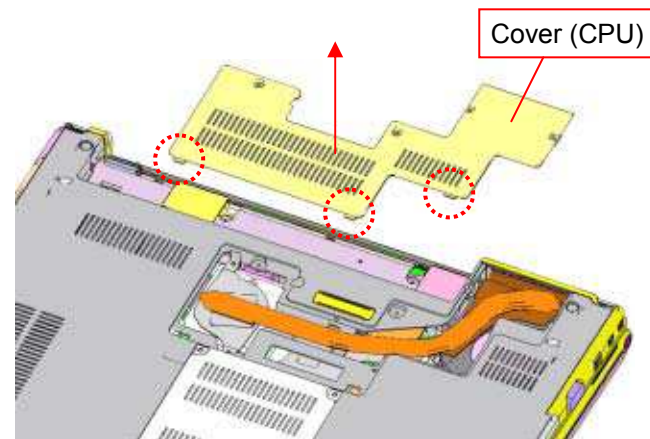

While disengaging the detent (three places), remove the Cover (CPU).

3)

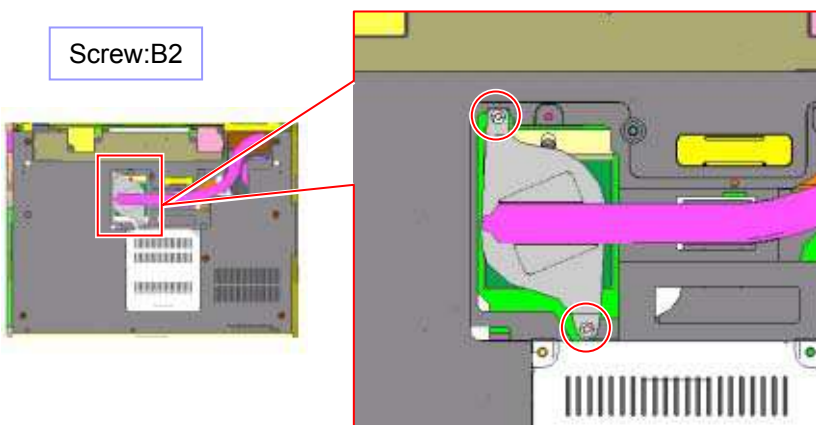

Remove the two screws.

4)

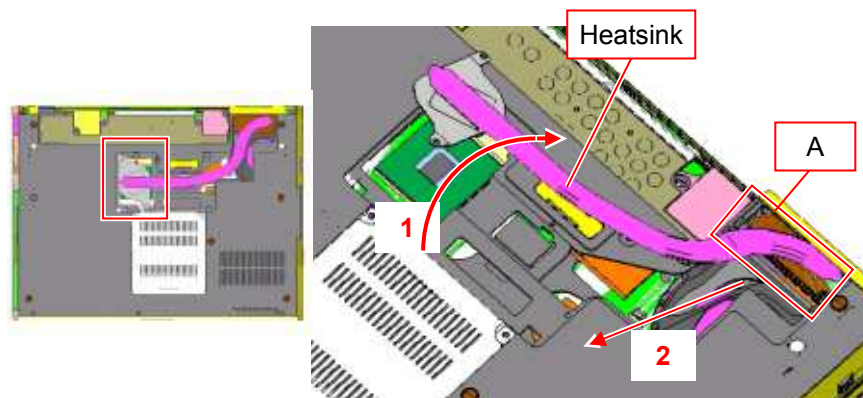

Raise the Heatsink in the direction of the arrow 1, and remove the Heatsink while removing the A portion diagonally upward (arrow 2).

## Cover (Memory)

1)

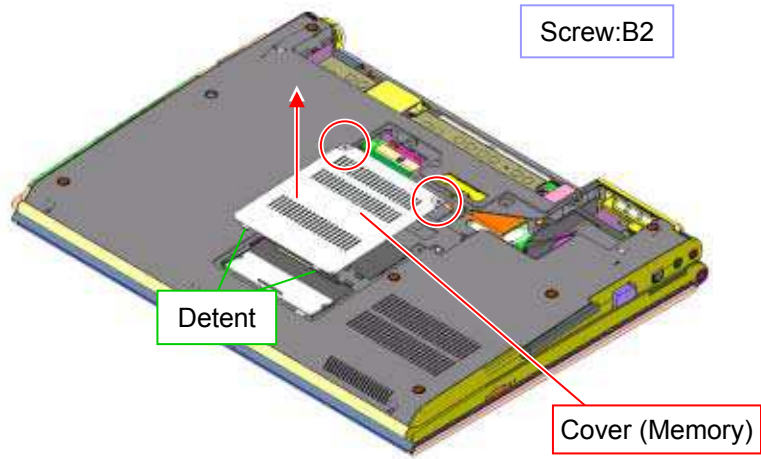

Remove the two screws, and remove the Cover (Memory) while disengaging the detent (two places).

2)

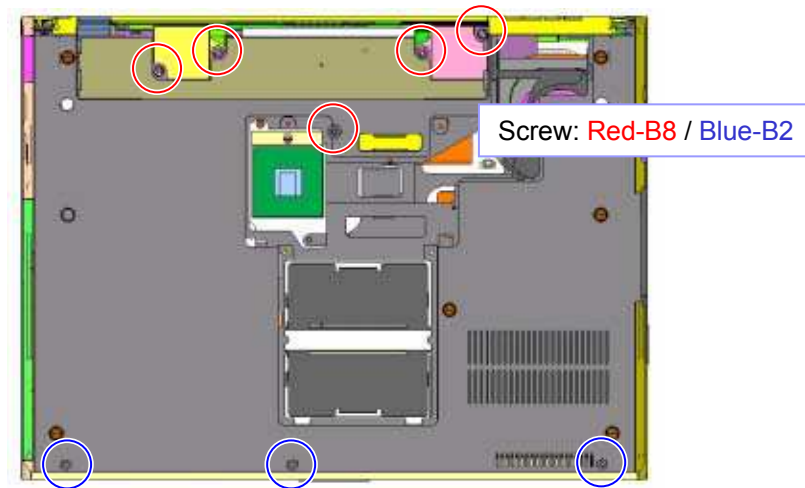

Remove the eight screws.

# Keyboard

1)

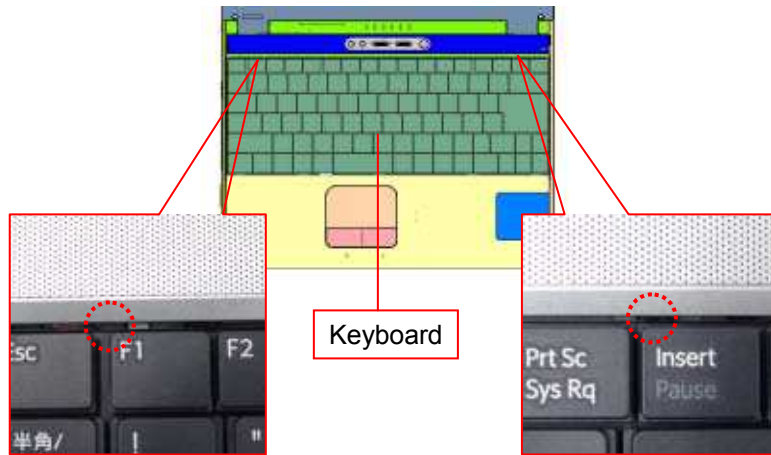

Disengage the detent (two places), and release the Keyboard.  
 \* Disengage the detent by pushing it by using a bamboo spatula.

2)

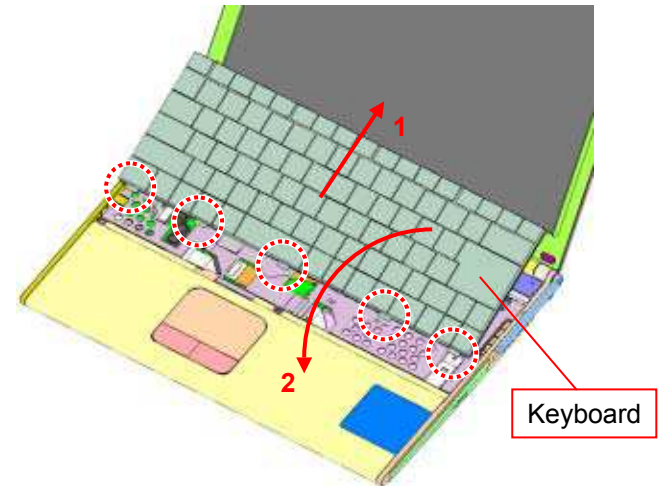

Slide the Keyboard in the direction of the arrow 1 to release the detent (five places), and turn it toward you and put it on the Plamrest.

3)

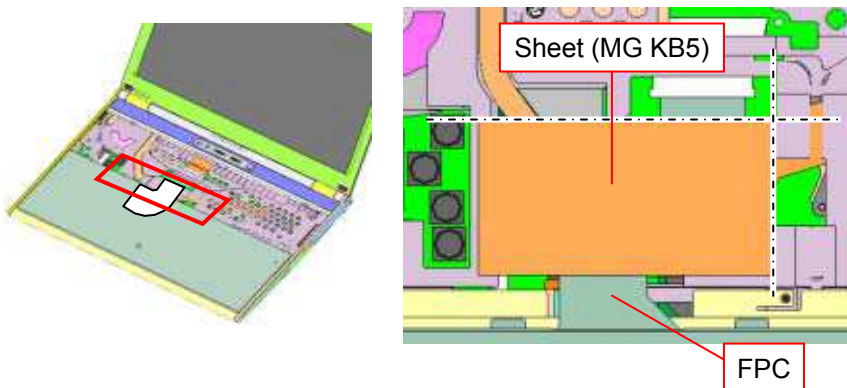

Peel off the Sheet (MG KB5).

4)

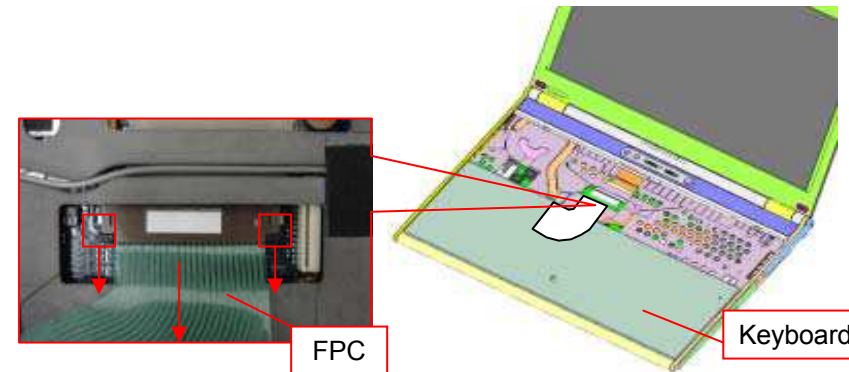

Slide the lock lever in the direction of the arrow to release the lock, disconnect the FPC, and then remove the Keyboard.

# Palmrest

1)

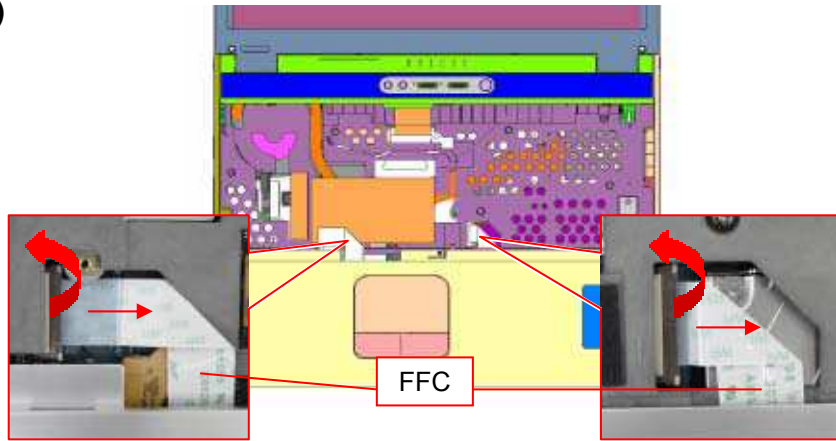

Raise the lock lever to release the lock, and disconnect the FFC (two places).

2)

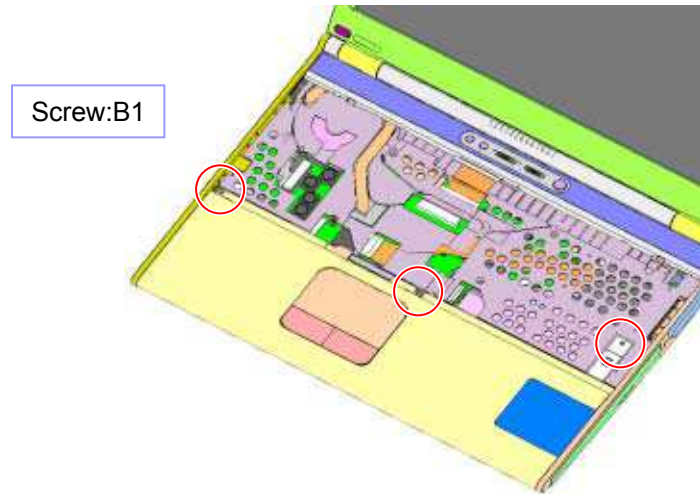

Remove the three screws.

3)

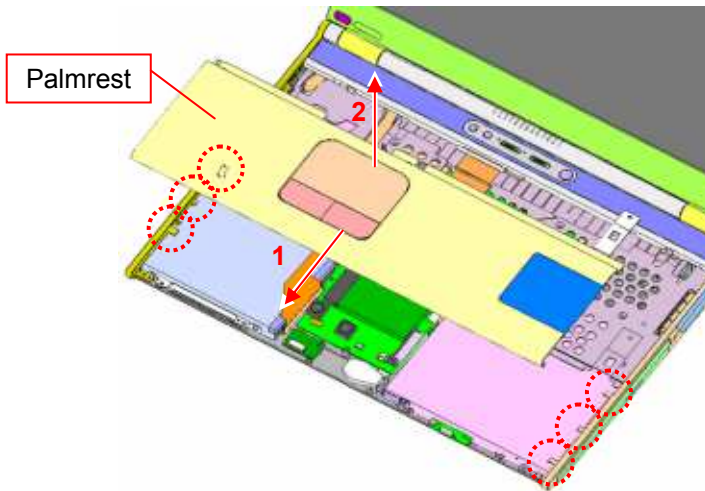

Disengage the detent (six places) by sliding the Palmrest in the direction of the arrow 1, and remove the Palmrest vertically upward.

# HDD

1)

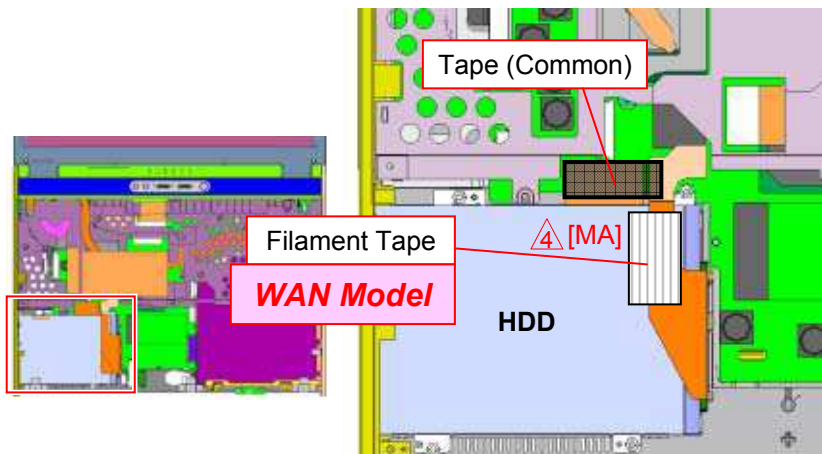

Peel off the Tape (Common) and Filament Tape.

2)

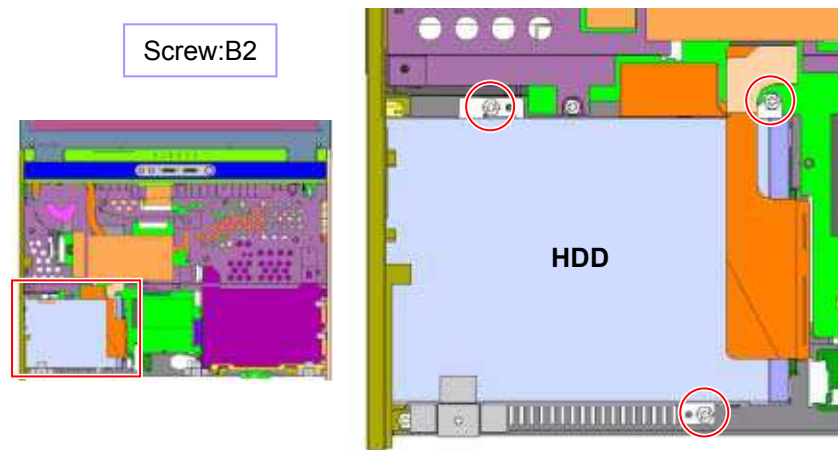

Remove the three screws.

3)

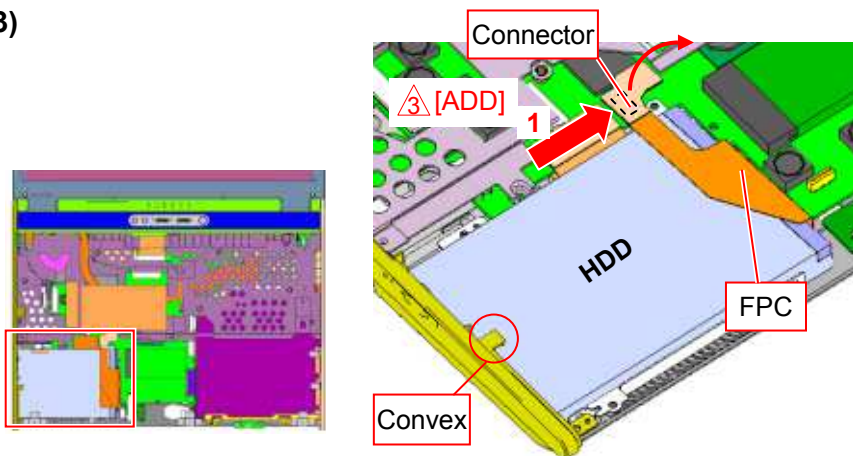

Disconnect the FPC, and remove the HDD while taking it out from under the convex portion (one place).

\* When disconnecting the FPC, be sure to remove it from the direction of the arrow 1.



## Parts of the HDD

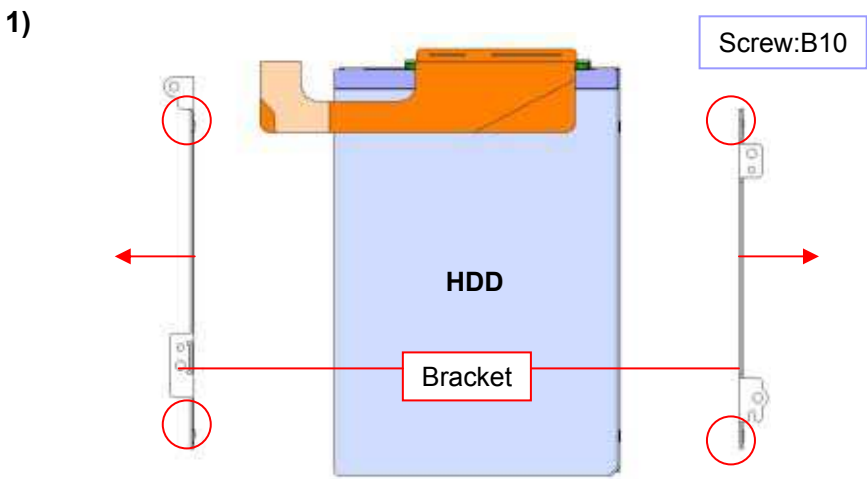

Remove the four screws, and then the Bracket (two places).

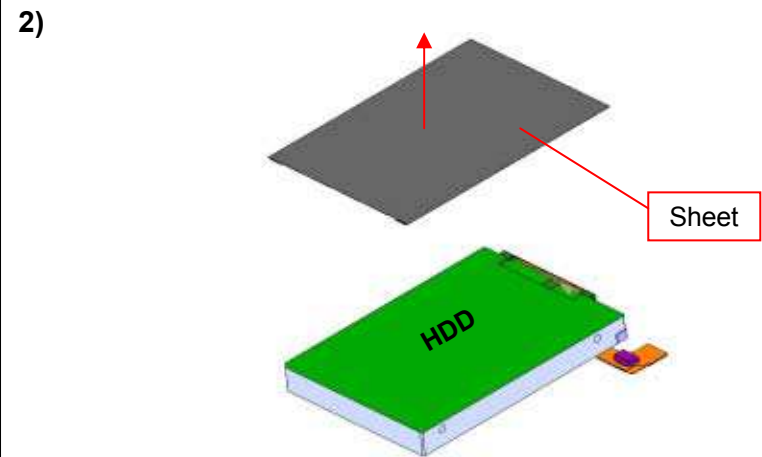

Peel off the Sheet from backside of the HDD.

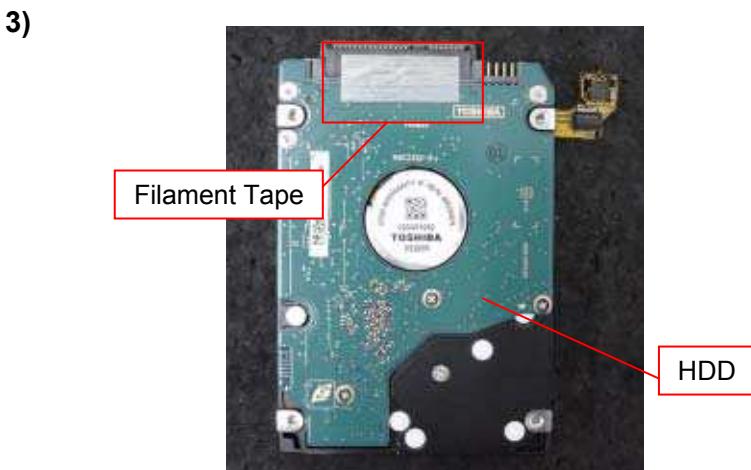

Peel off the Filament Tape.

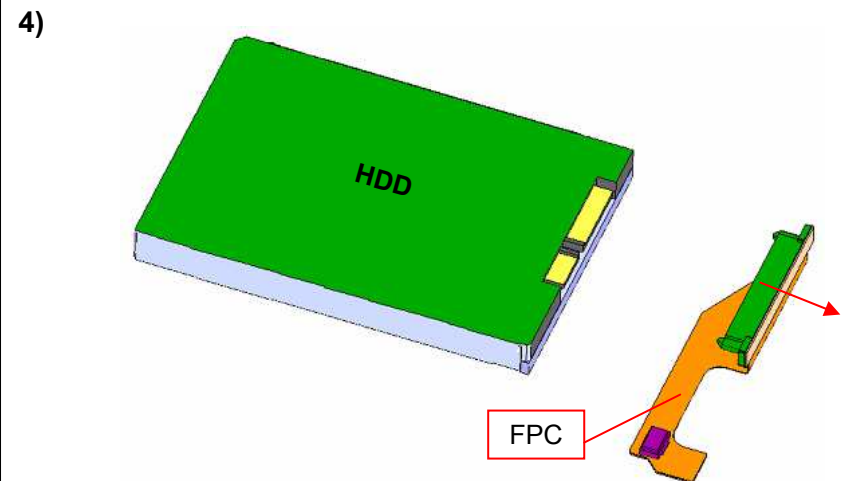

Disconnect the FPC.

## Hood (Keyboard)

1)

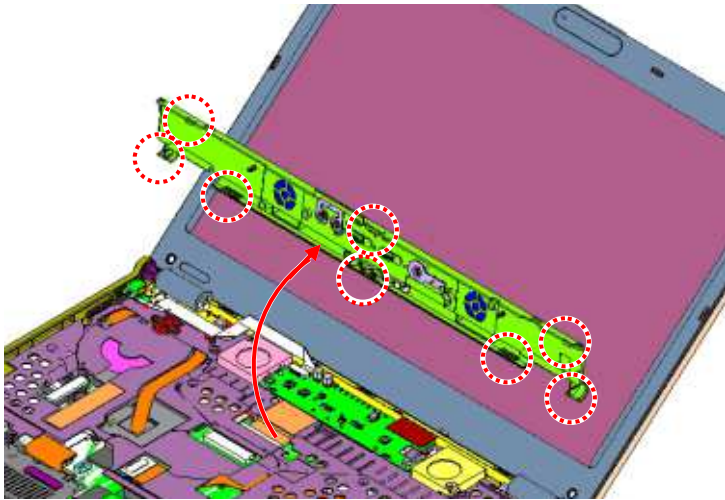

Turn up the Hood (Keyboard) from the front and disengage the detent (eight places).

2)

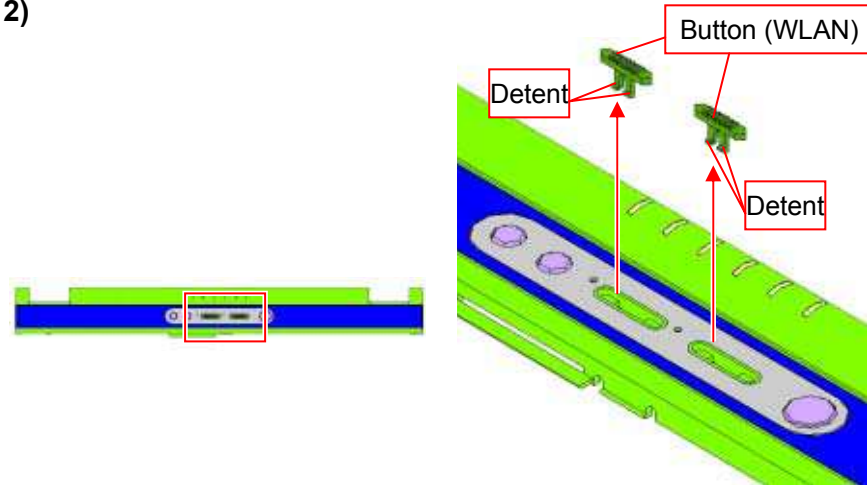

While disengaging the detent (two places) respectively, remove the Button (WLAN) (two places).

# SWX-214 Board

1)

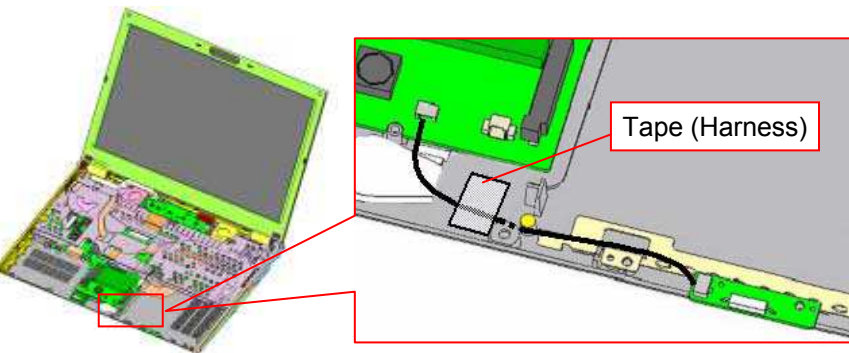

Peel off the Tape (Harness).

2)

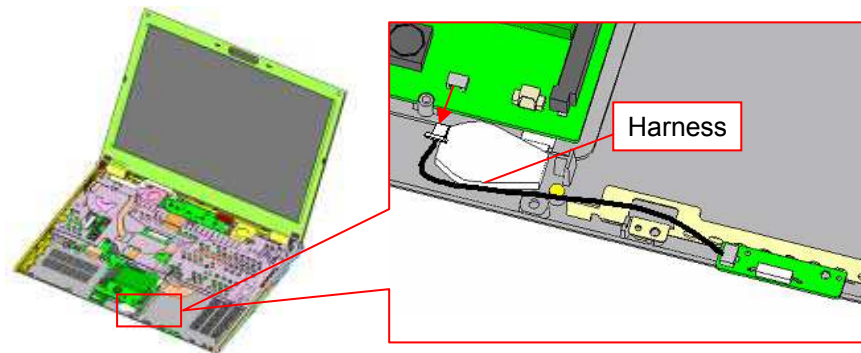

Disconnect the Harness.

3)

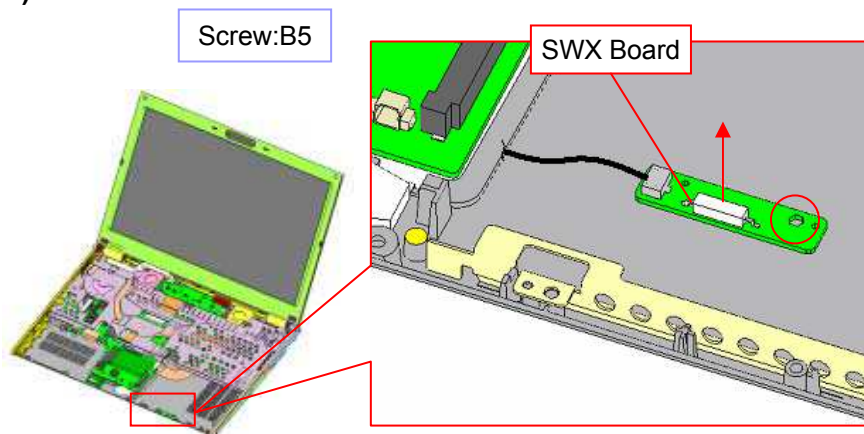

Remove the one screw, and then the SWX Board.

4)

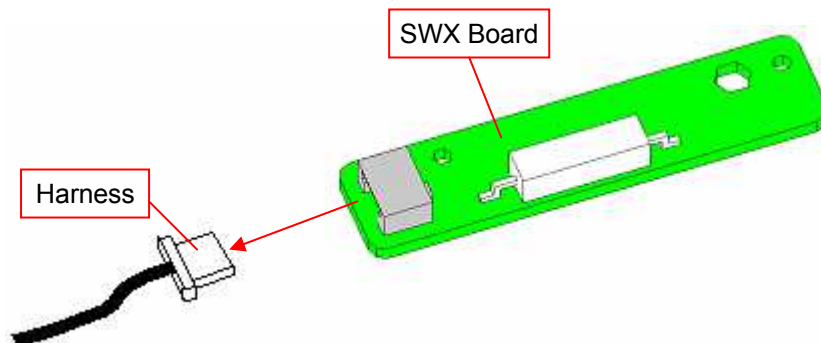

Disconnect the Harness.

# IFX-437 Board

TPM Model

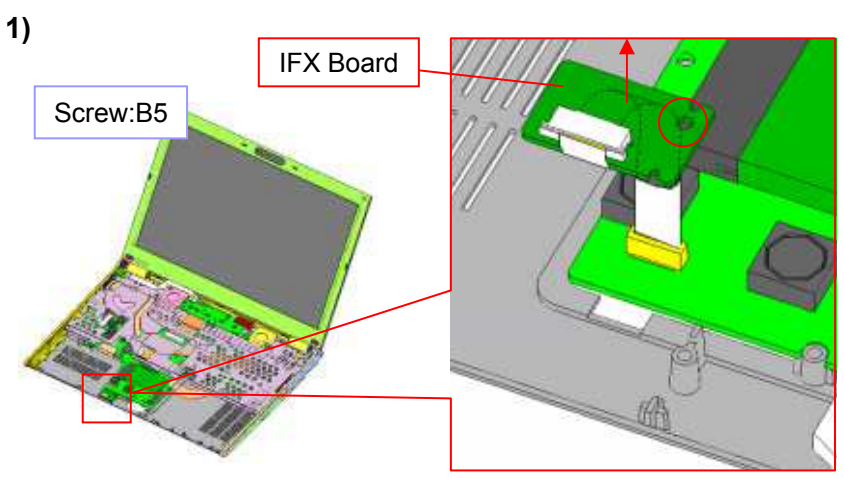

Remove the one screw, and then the IFX Board.

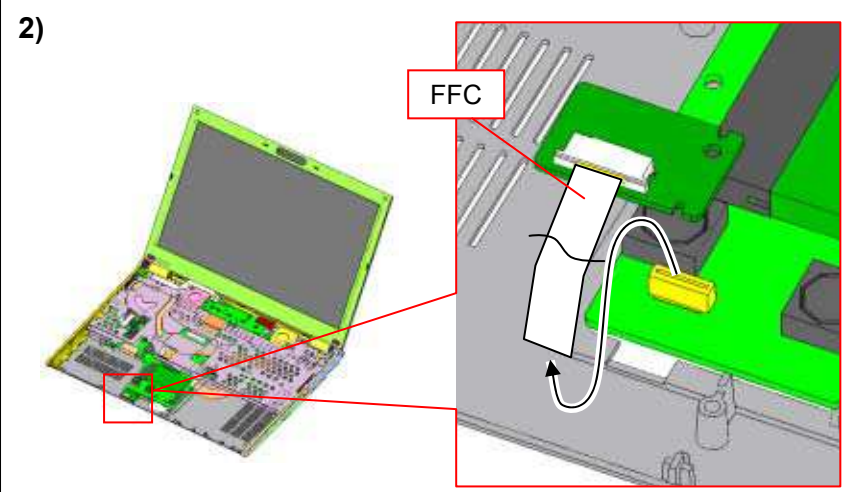

Pull out the FFC vertically and disconnect it.

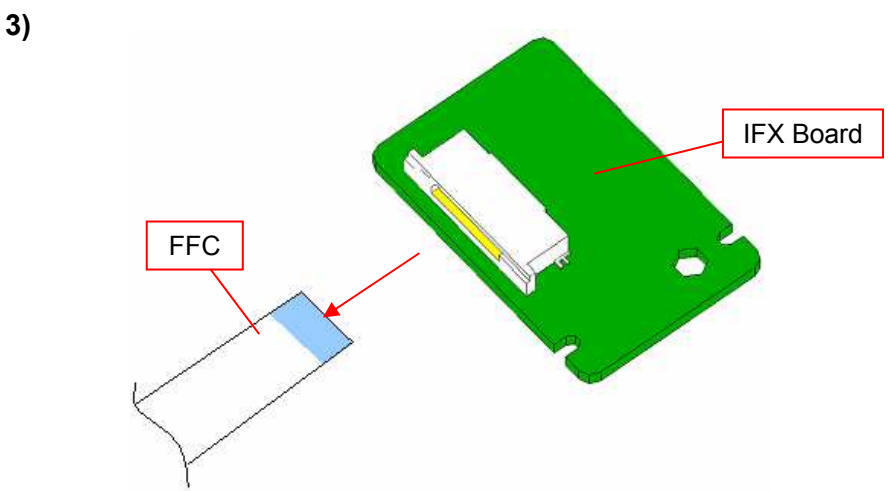

Pull out the FFC in the direction of the arrow.

## Reserve Battery

1)

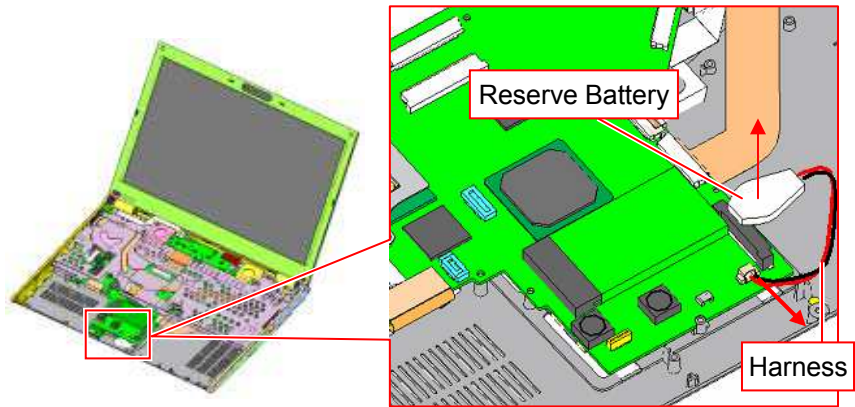

Disconnect the Harness, and remove the Reserve Battery.

\* The adhesive tape is attached on the bottom of it.

# Wireless LAN Card

1)

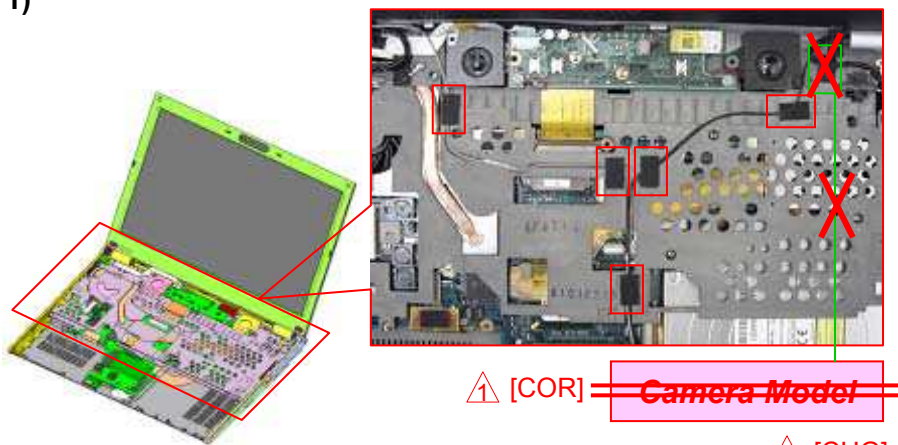

~~⚠ [COR] Camera Model~~

⚠ [CHG]

Peel off the Sheet (Paste Cable) (five places).

~~Camera Model Six places~~

~~Other Five places~~

2)



Move the tab (two places) in the direction of the arrow 1 to release the lock, and pull out the Wireless LAN Card diagonally upward (arrow2).

3)

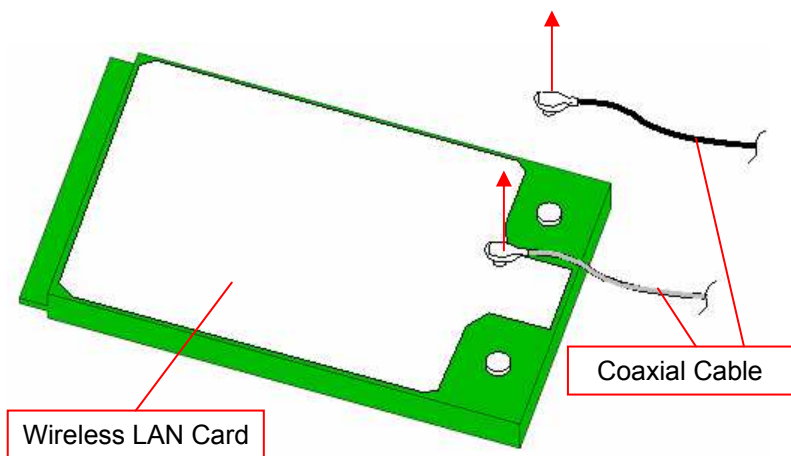

Disconnect the coaxial cable (two places).

\* Pull out it **vertically**.

## IFX-442 Board

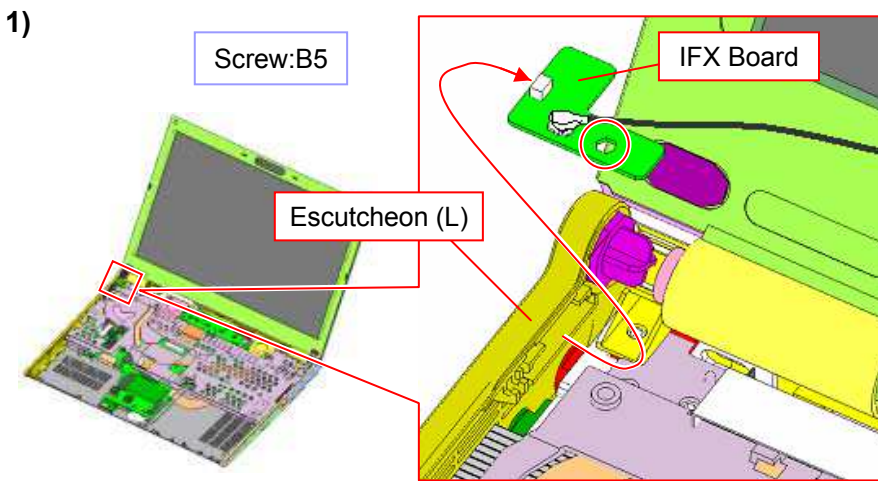
**Bluetooth Model**

Remove the screw, and remove the IFX Board while releasing it from the Escutcheon (L).

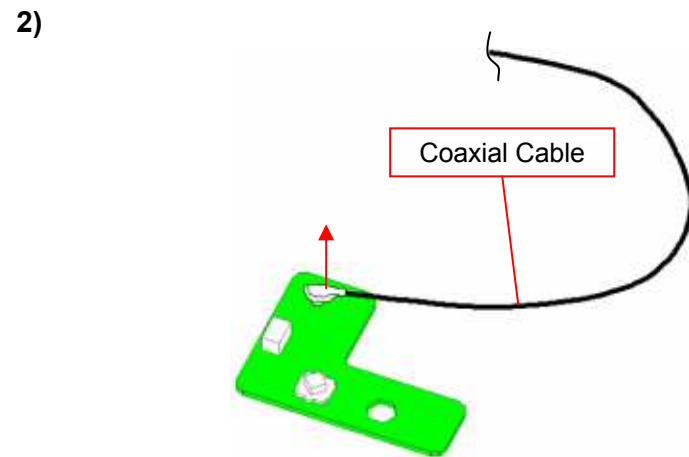

Disconnect the coaxial cable.  
\* Pull out it **vertically**.

# LCD -1

1)

Screw:B13

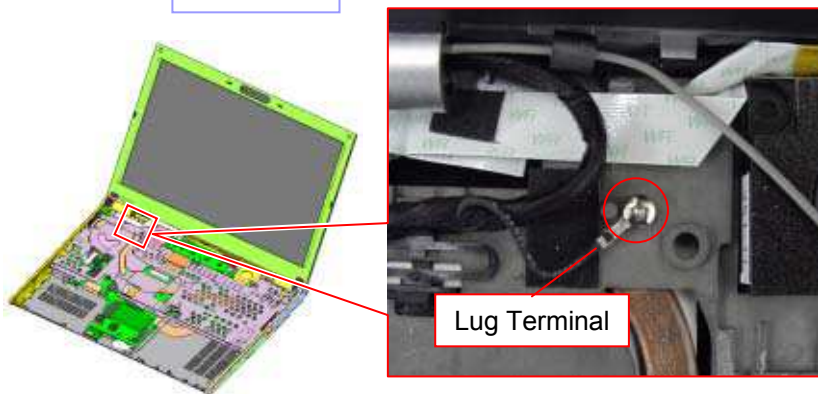

Remove the one screw.  
\* It secures the Lug Terminal.

2) ⚠️ [ADD]

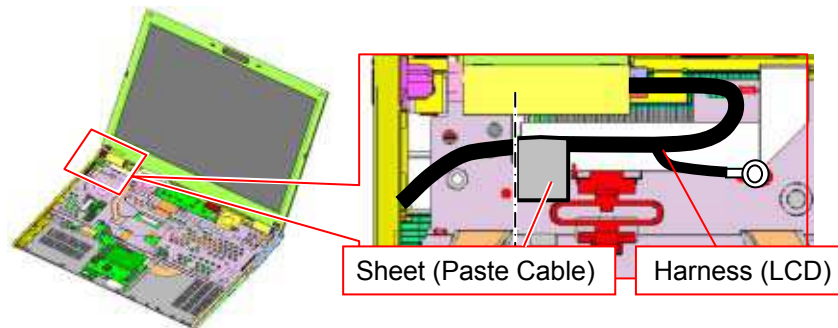

Peel off the Sheet (Paste Cable).

3)

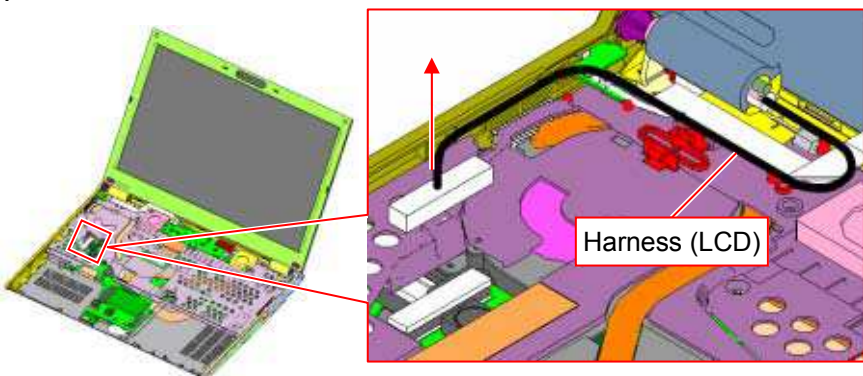

Disconnect the Harness (LCD).

4)

**Camera Model**

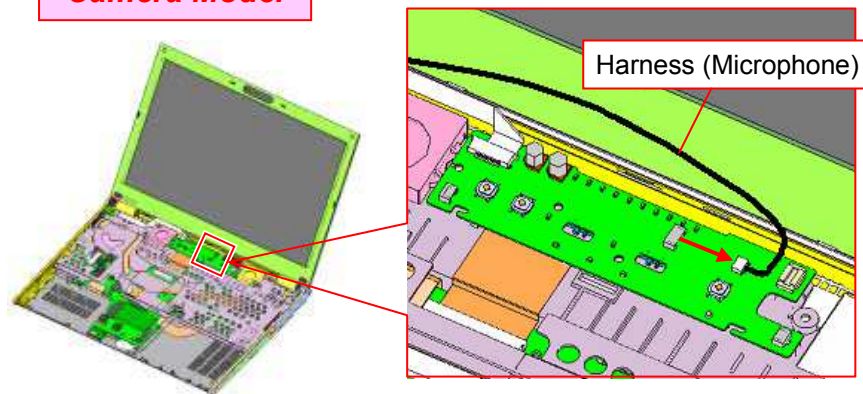

Disconnect the Harness (Microphone).



# LCD -2

5)

Camera Model

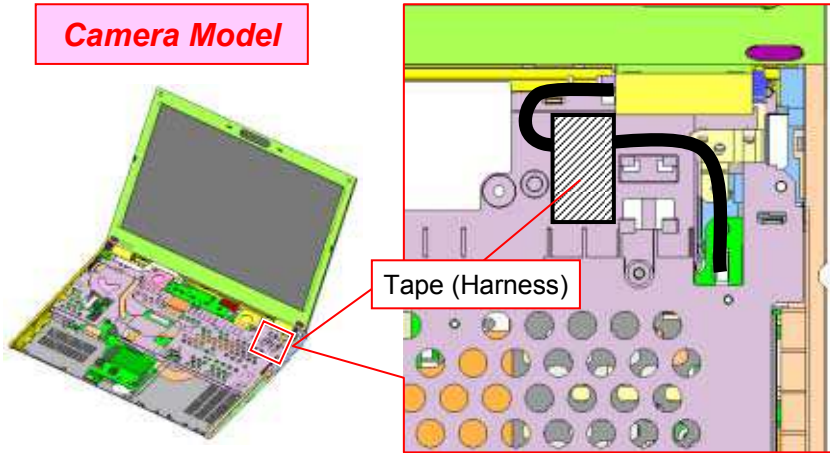

Peel off the Tape (Harness).

6)

Camera Model

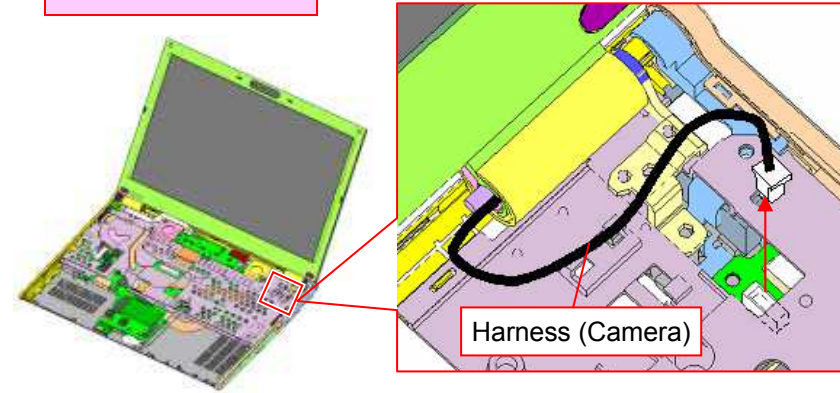

Disconnect the Harness (Camera).

7)

Screw: B8

LCD

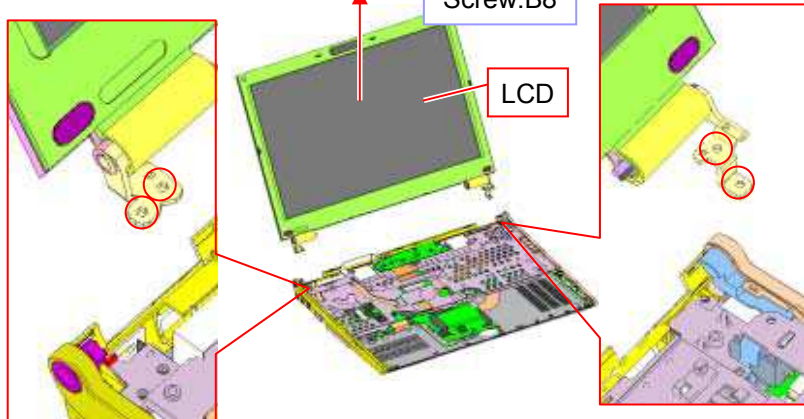

Remove the four screws, and then the LCD.

# Cap (Hinge), Speaker (R)

1)

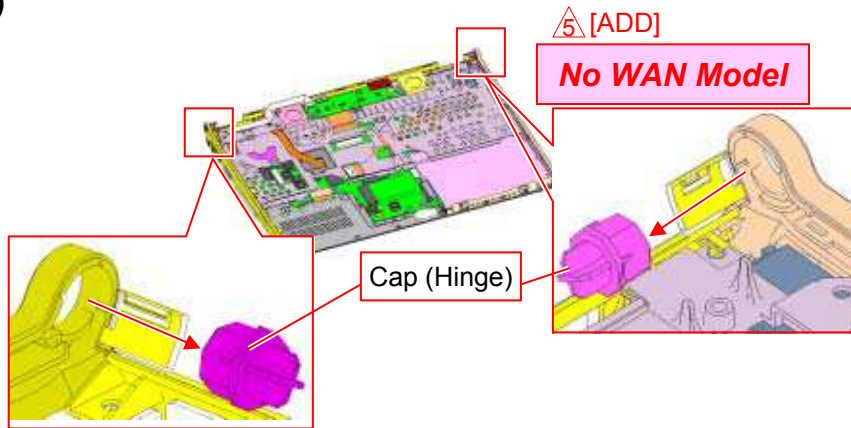

Remove the Cap (Hinge) .

\*WAN Model --- One place

No WAN Model --- Two places

2)

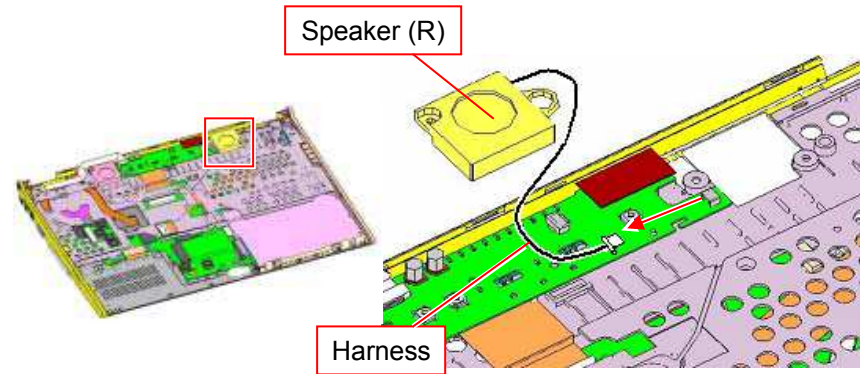

Disconnect the Harness, and remove the Speaker (R).

# Bluetooth Module

*Bluetooth Model*

1)

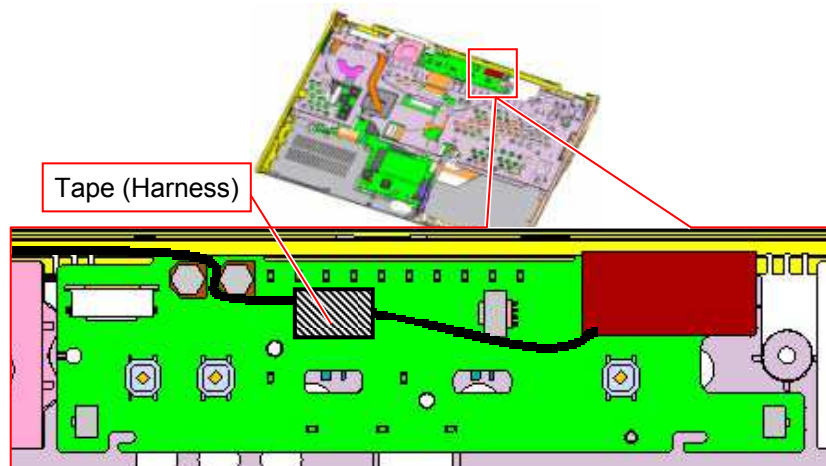

Peel off the Tape (Harness).

2)

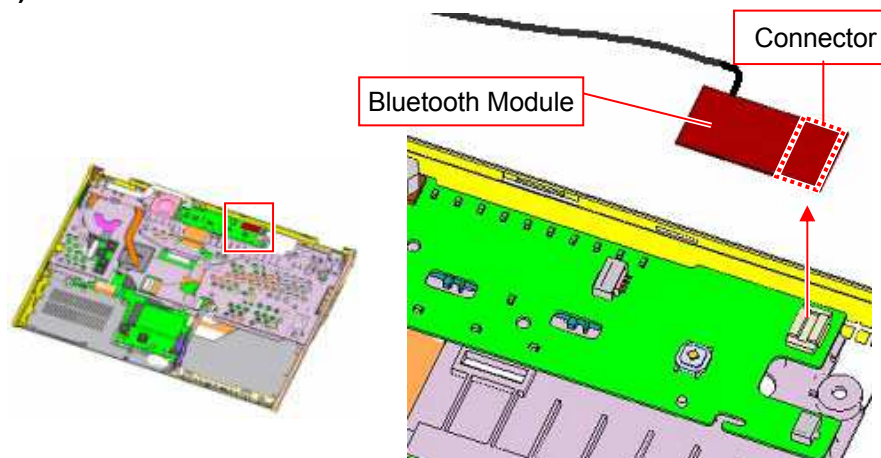

Remove the Bluetooth Module.

3)

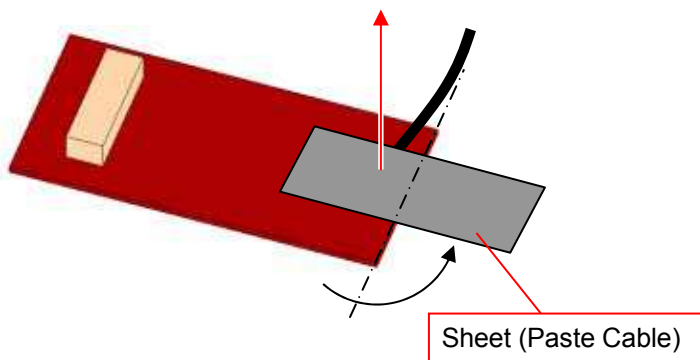

⚠ [CHG]  
Peel off the Sheet (Paste Cable).

4)

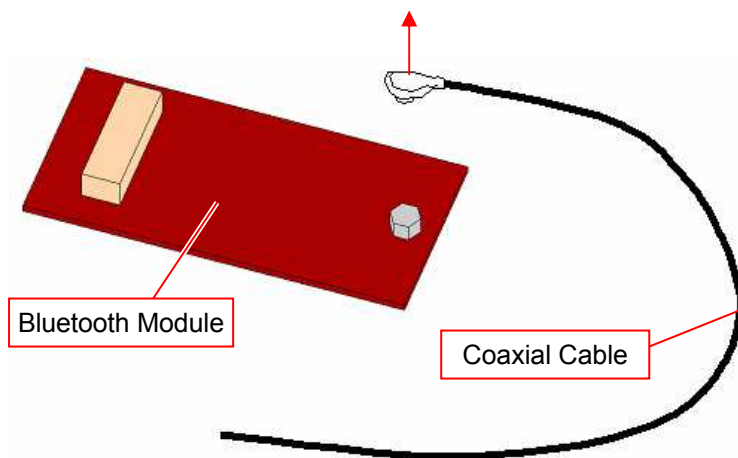

Disconnect the coaxial cable.  
\* Pull out it **vertically**.

## ANL-66 Board -1

1)

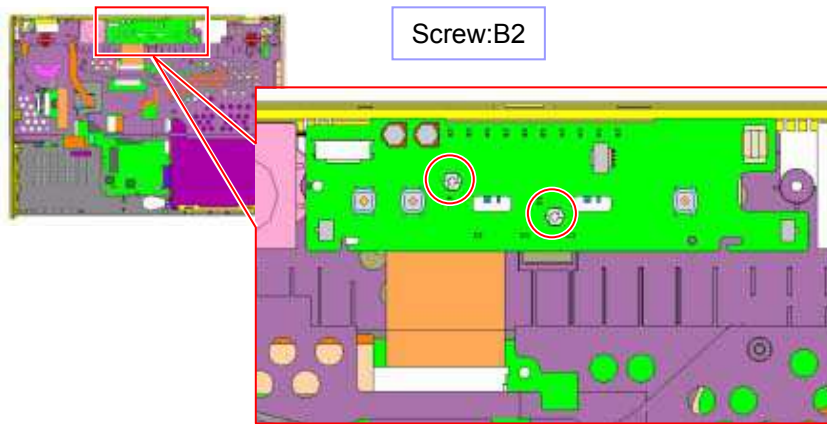

Remove the two screws.

2)

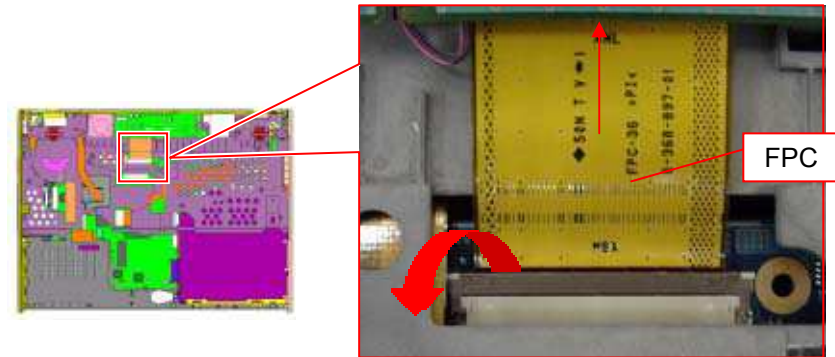

Raise the lock lever to release the lock, and disconnect the FPC.

3)

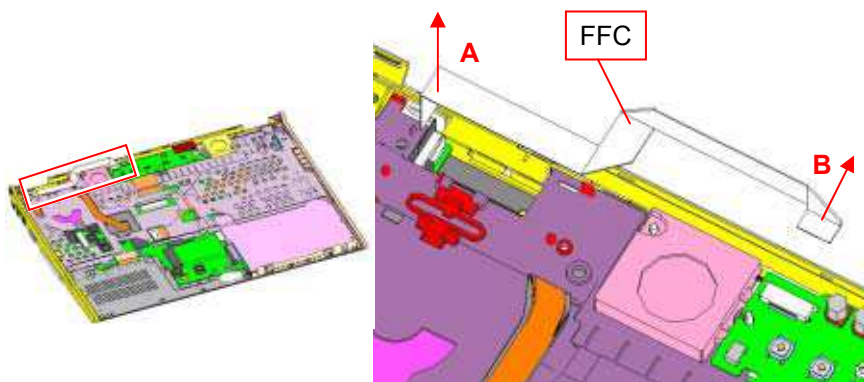

Disconnect the FFC.

\*A: Pull out it vertically upward.

B: Pull out it in the direction of the arrow.

4)

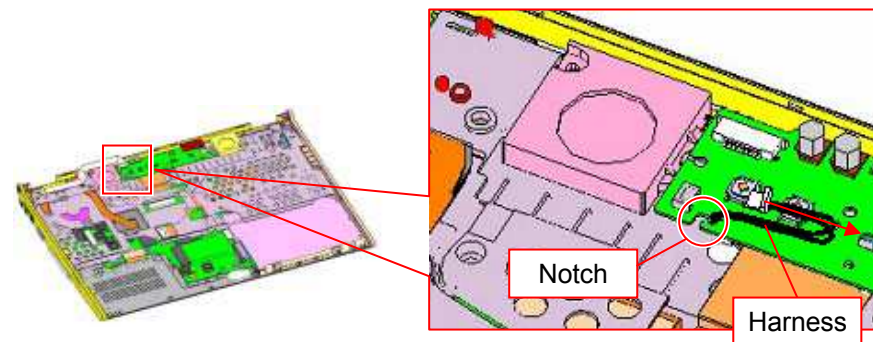

Disconnect the Harness, and release it from the notch.

# ANL-66 Board -2

5)

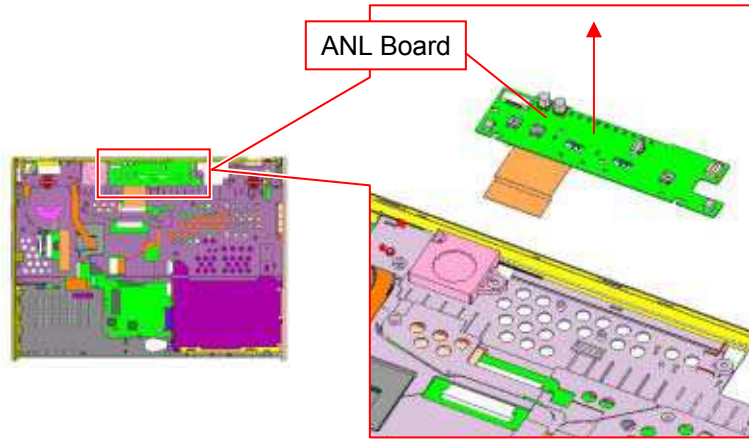

Remove the ANL Board.

6)

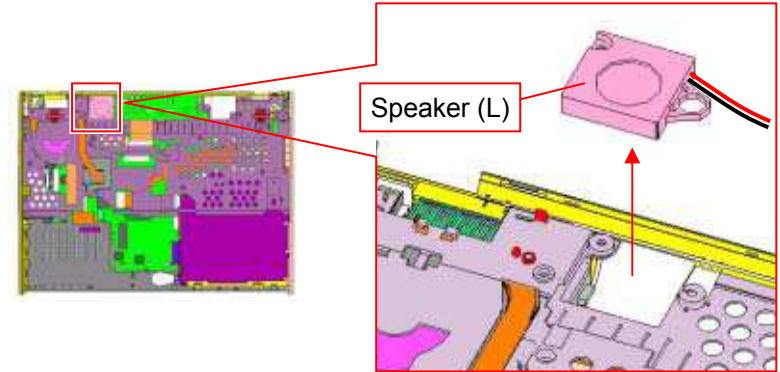

Remove the Speaker (L).

# Chassis (MG)

1)

Screw: Red-B8 / Blue-B9

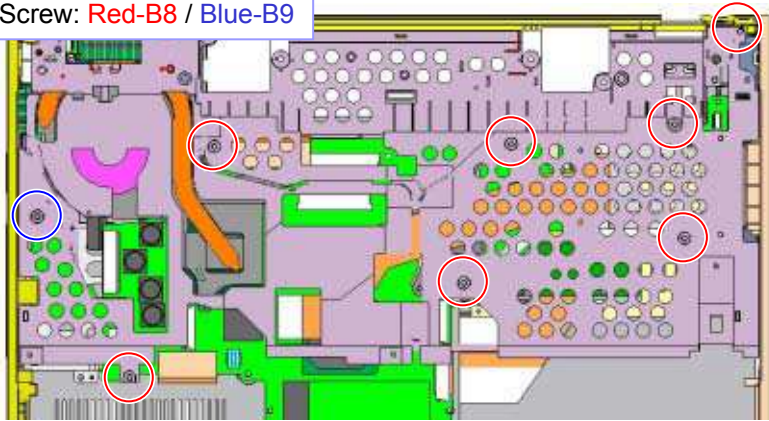

Remove the eight screws.

2)

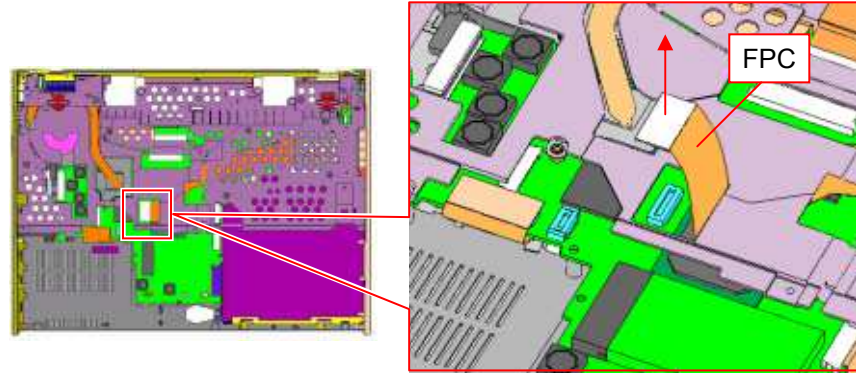

Disconnect the FPC vertically upward.

3)

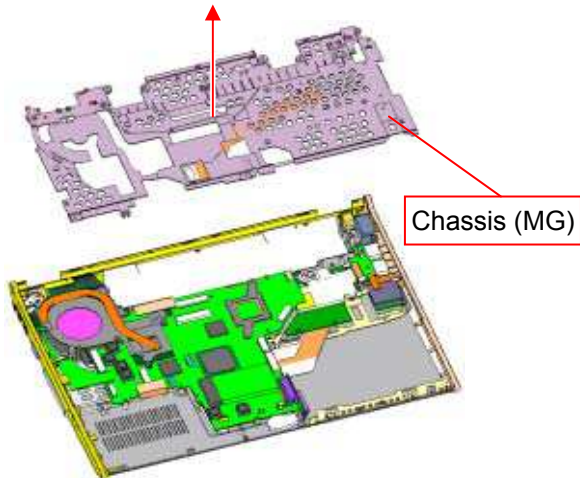

Remove the Chassis (MG).

## Parts of the Chassis (MG)

1)

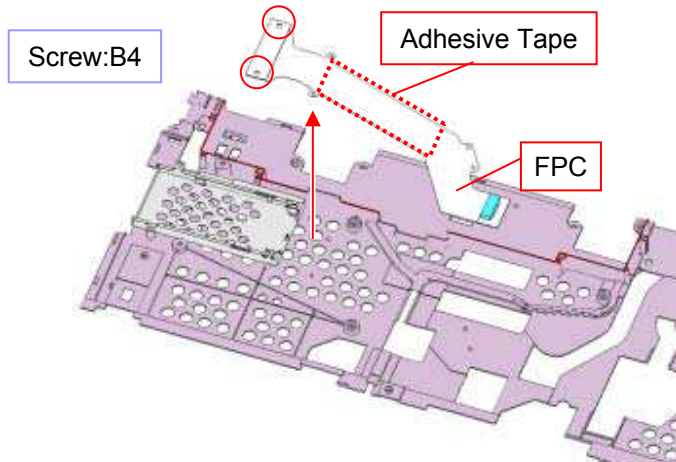

Remove the two screws, and disconnect the FPC.  
\* The adhesive tape is attached on the bottom of it.

2)

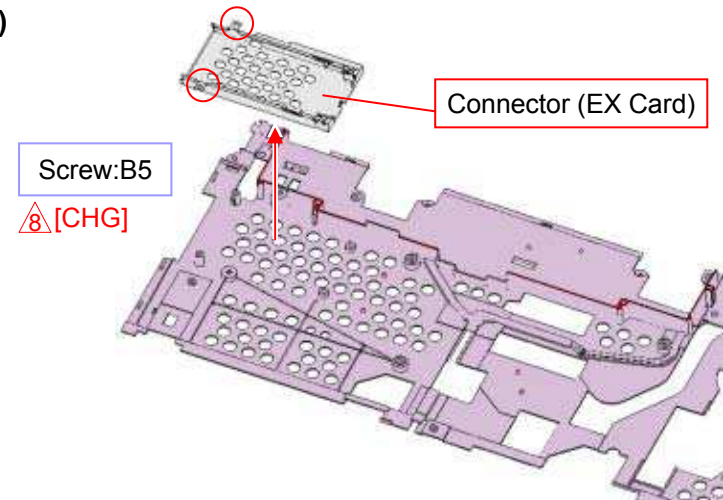

Remove the two screws, and then the Connector (EX Card).

# Optical Disc Drive

1)

Screw:B2

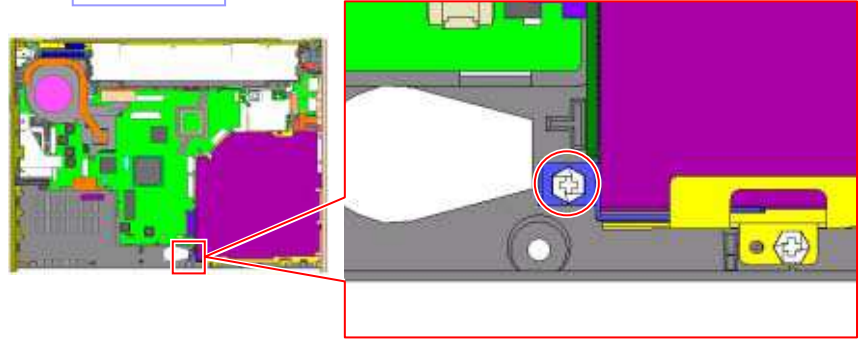

Remove the one screw.

2)

Connector

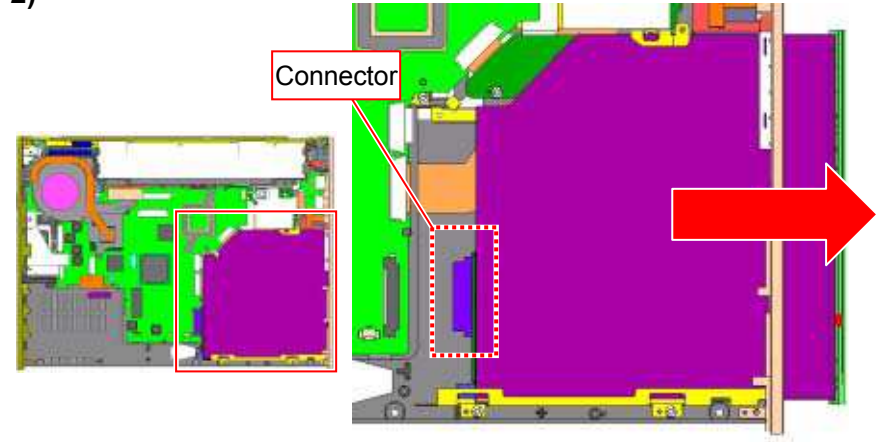

Remove the Optical Disc Drive while disconnecting the connector.



## IFX-435 Board -1

1)

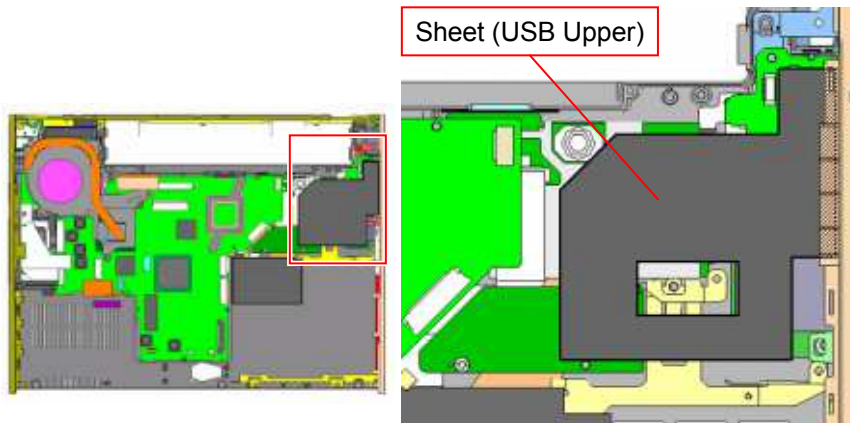

Peel off the Sheet (USB Upper).

2) ⚠ [MA]

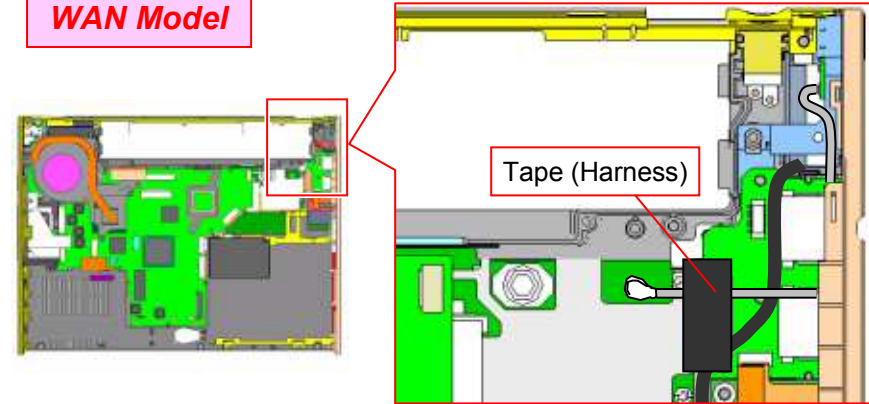
**WAN Model**

Peel off the Tape (Harness).

3)

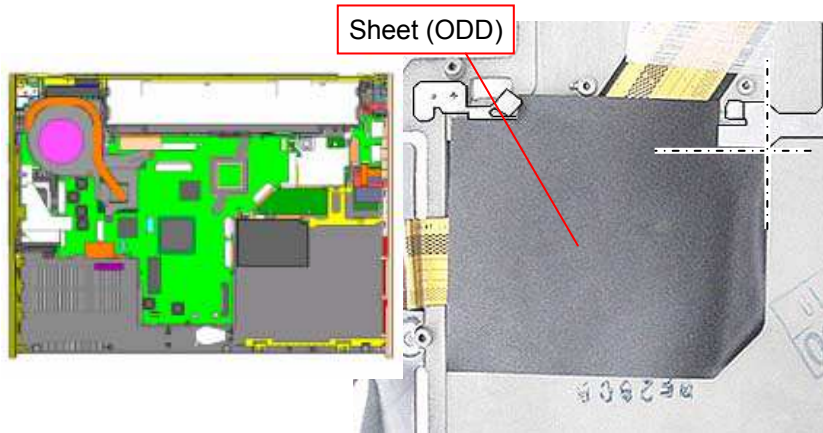

Peel off the Sheet (ODD).

4) ⚠ [MA]

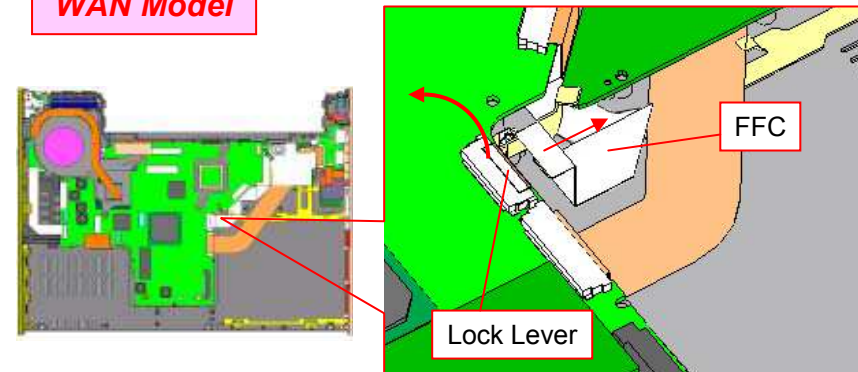
**WAN Model**

Raise the lock lever to release the lock, and remove the FFC coming from the WWAN Unit.

## IFX-435 Board -2

5)

Screw:B5

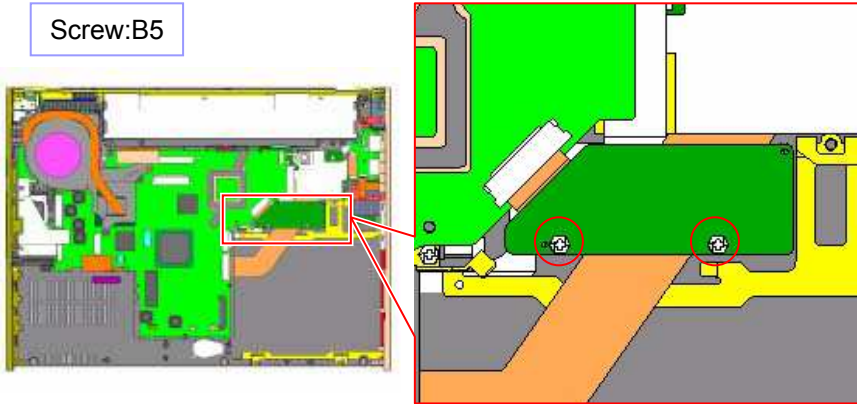

Remove the two screws.

6)

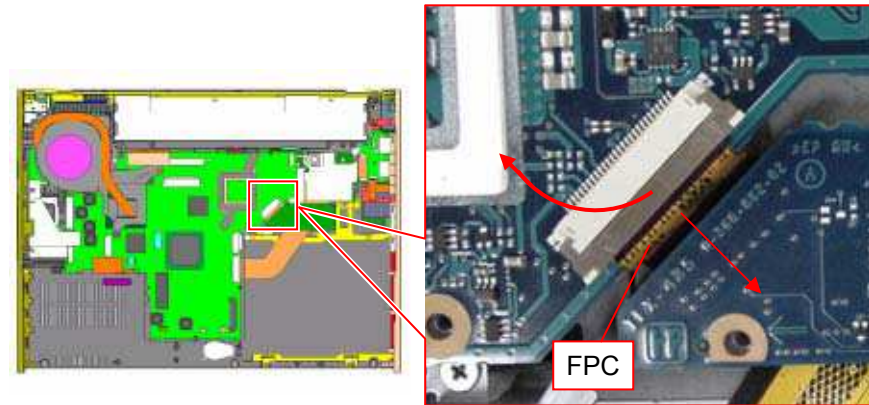

Raise the lock lever to release the lock, and disconnect the FPC.

7)

IFX Board

Harness

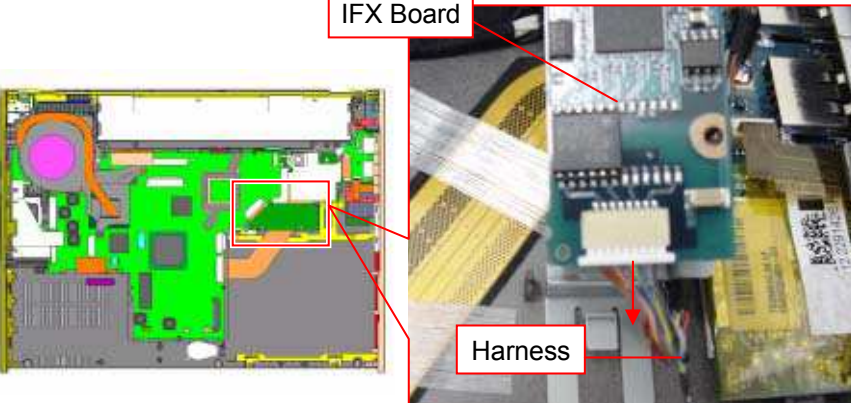

Turn over the IFX Board, and disconnect the Harness.

## Parts of the IFX-435 Board

1)

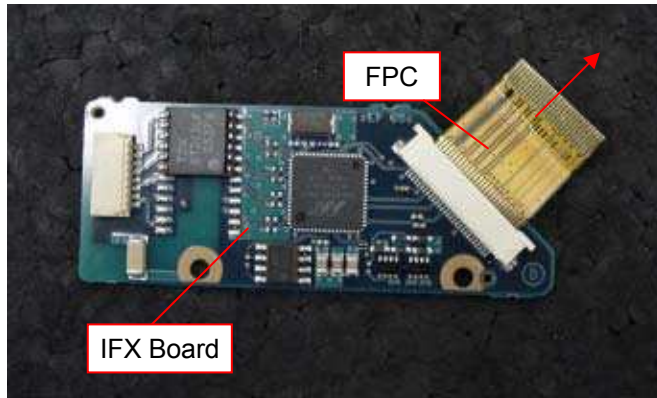

Pull out the FPC in the direction of the arrow.

**DDC-5 Board****Brighter\_LED Model**

1)

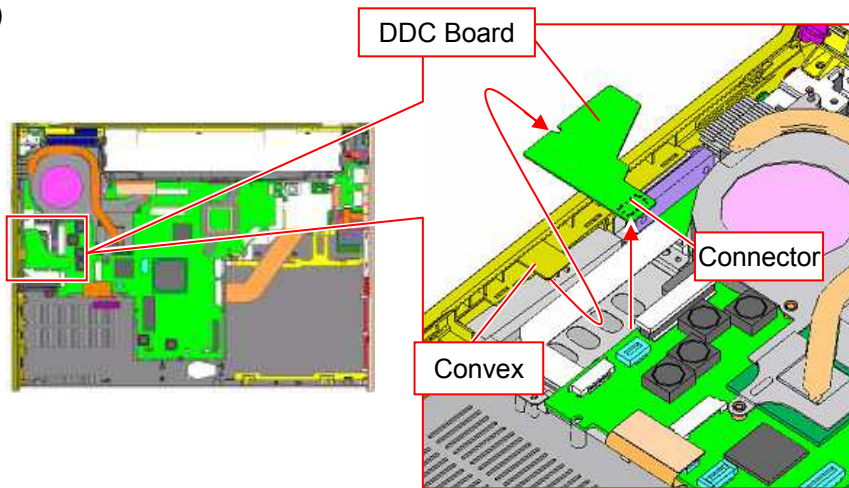

Disconnect the connector, and remove the DDC Board while pulling it out from under the convex portion.

## Cover (BATT)

1)

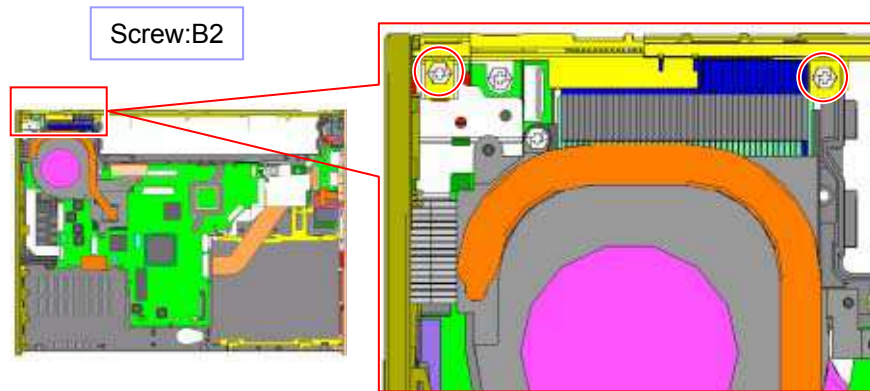

Remove the two screws.

2)

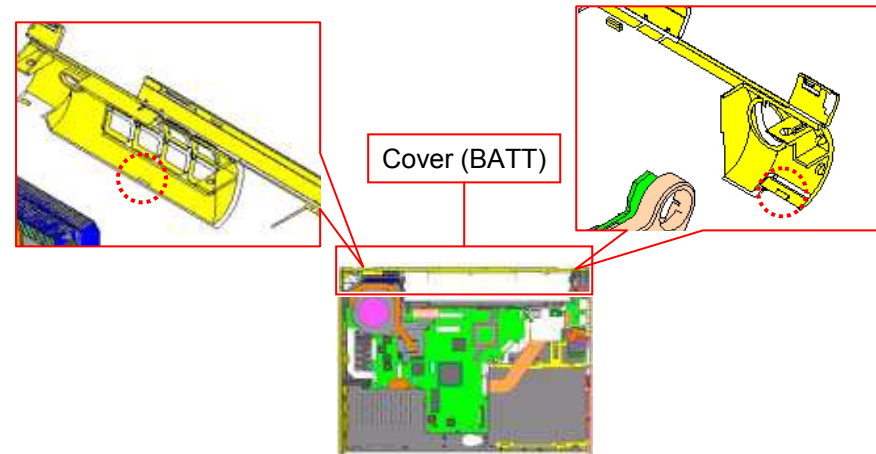

While disengaging the detent (two places), remove the Cover (BATT).

# Mother Board -1

1) ⚠️ [MA]

**WAN Model**

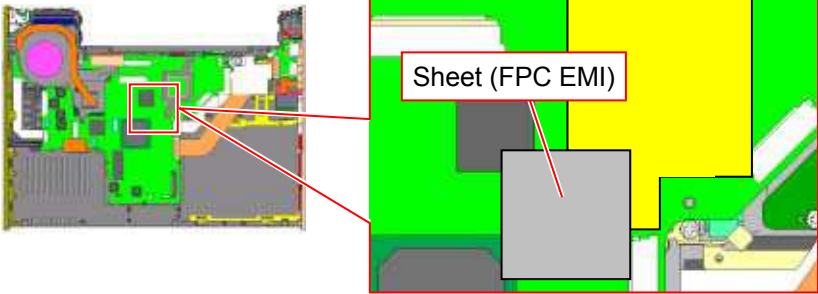

Peel off the Sheet (FPC EMI).

2) ⚠️ [ADD]

⚠️ [COR]

**WAN & EU Area (Except SZ1HRP, SZ1XRP )Model**

⚠️ [MA]

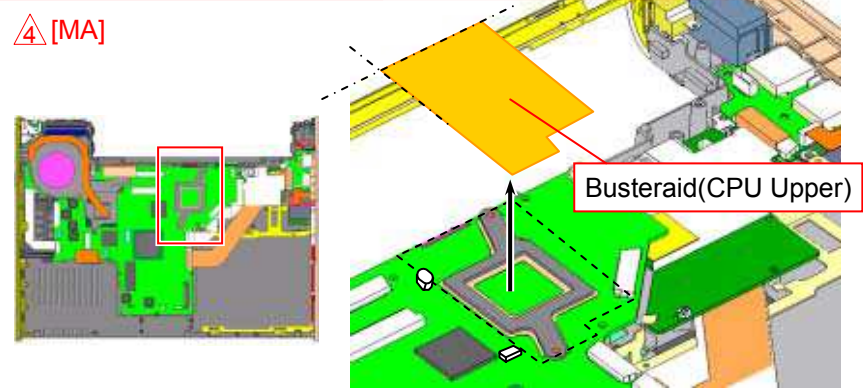

Peel off the Bustraid (CPU Upper).

3)

⚠️ [ADD]

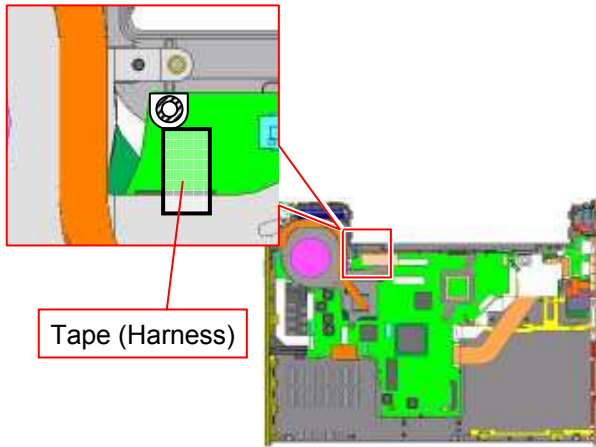

Peel off the Tape (Harness).

4)

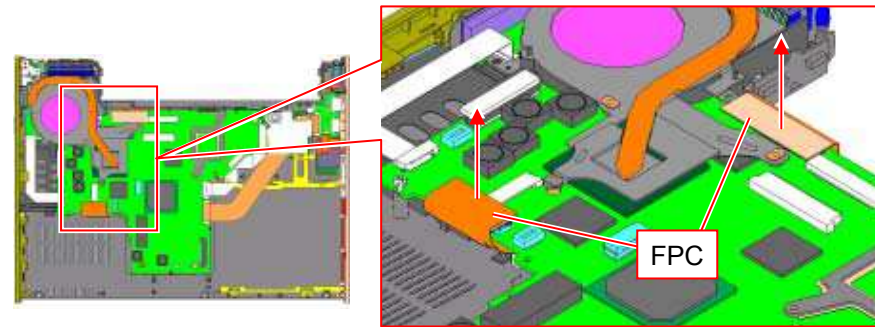

Pull out the FPC (two places) vertically.

# Mother Board -2

5)



Disconnect the FPC (two places).

\*A : Pull out it in the direction of the arrow.

B : Raise the lock lever to release the lock, and disconnect the FPC.

6)

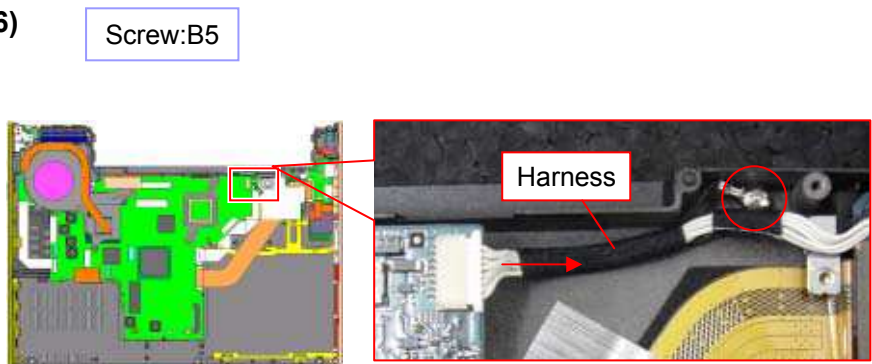

Remove the one screw, and disconnect the Harness.

\* The screw secures the lug terminal.

7)

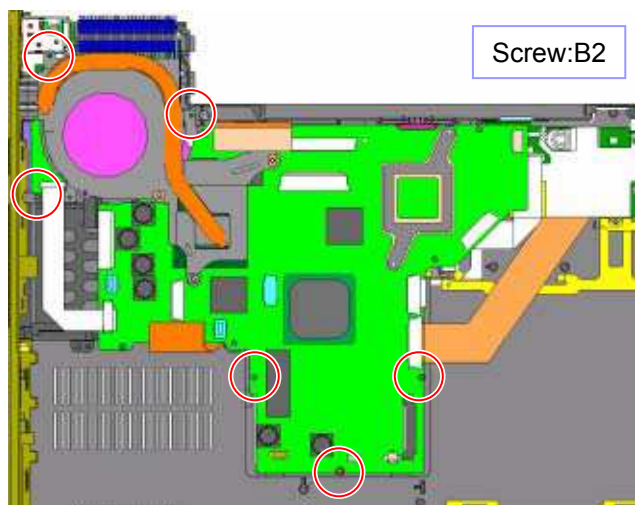

Remove the six screws.

[ADD]

8)

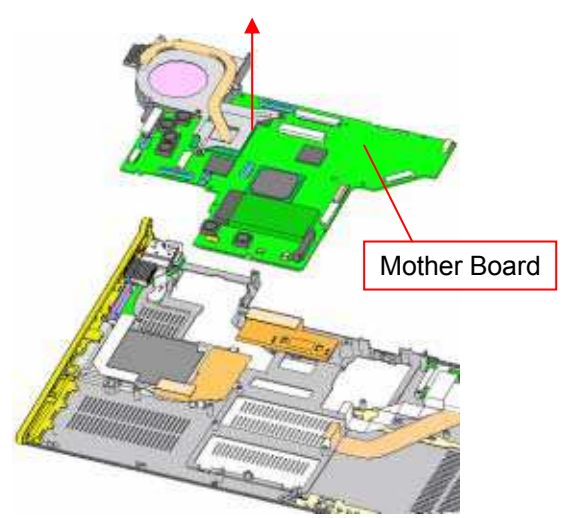

Remove the Mother Board.

# WWAN Unit -1

## WAN Model

1)

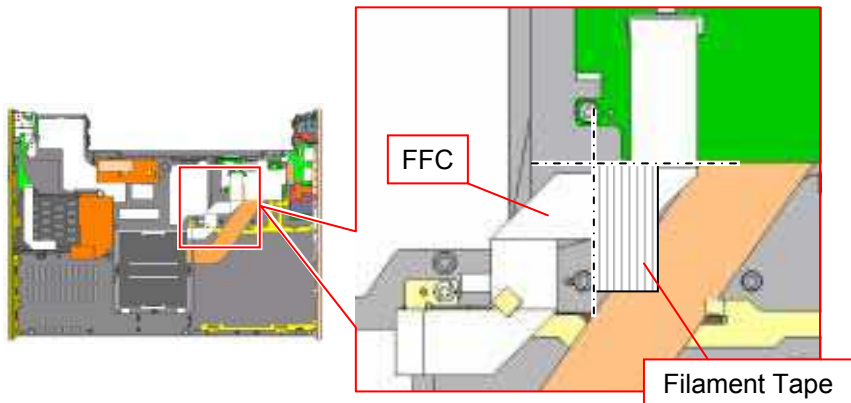

Peel off the Filament Tape.

2)

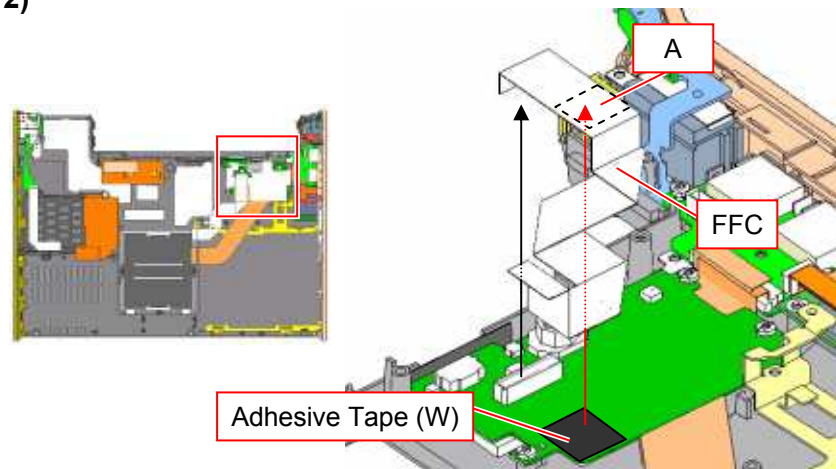

Disconnect the FFC vertically, and peel off the A portion from the Adhesive Tape.

3)

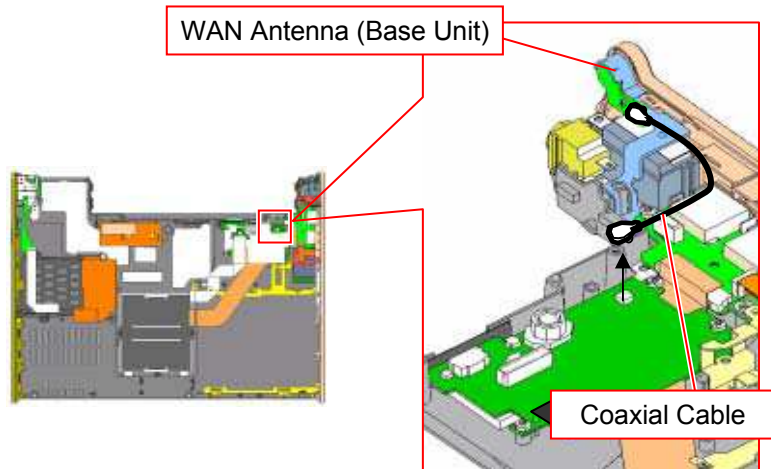

Disconnect the coaxial cable coming from the WAN Antenna (Base Unit).  
 \* Disconnect the coaxial cable **vertically**.

4)

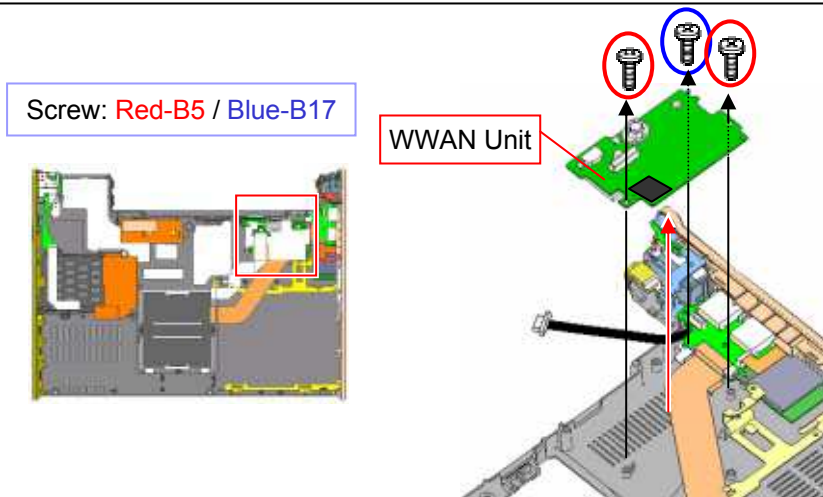

Remove the three screws and the WWAN Unit.



# WWAN Unit -2

WAN Model

5)

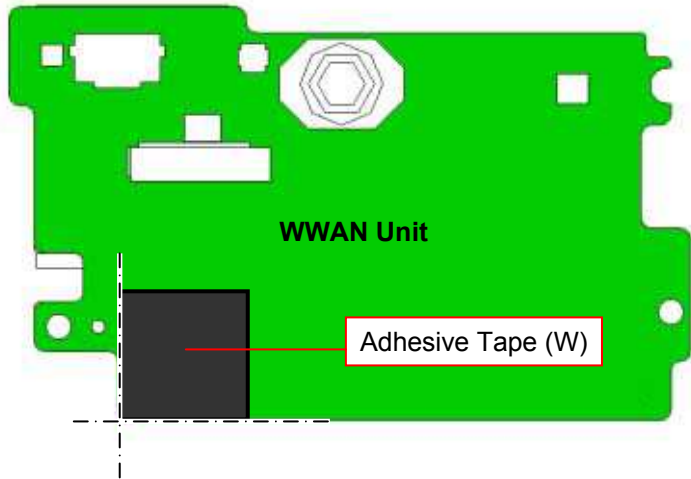

Peel off the Adhesive Tape.

# FPC, Card (Modem)

1)

Screw:B8

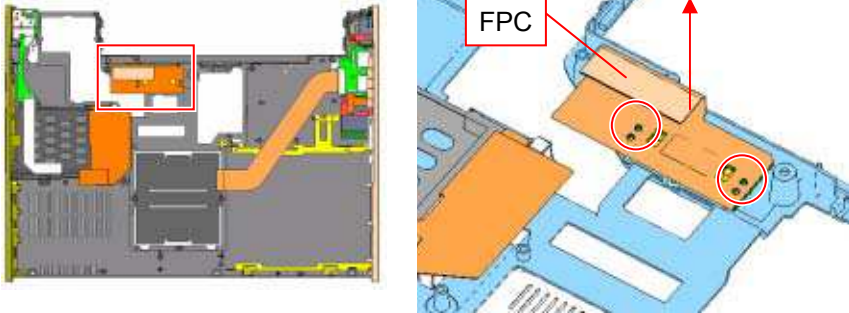

Remove the two screws, and then the FPC.

2)

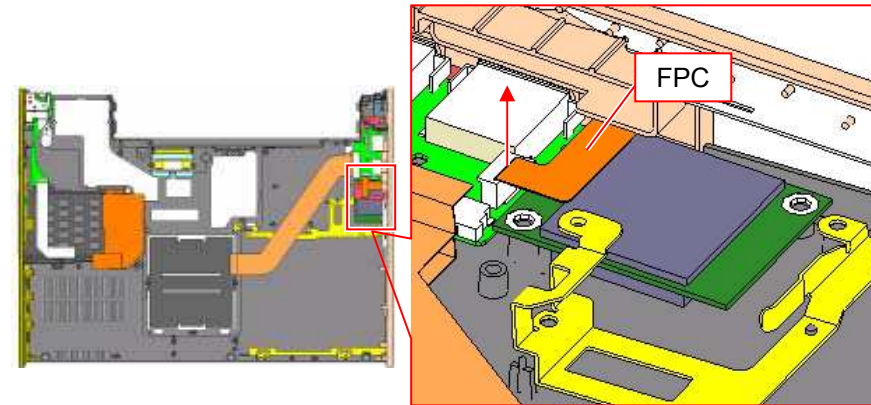

Pull out the FPC vertically upward, and disconnect it.

3)

Screw:B5

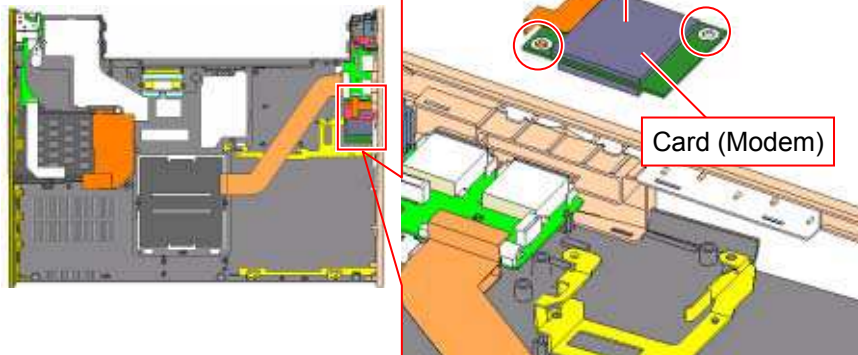

Remove the two screws, and then the Card (Modem).

4)

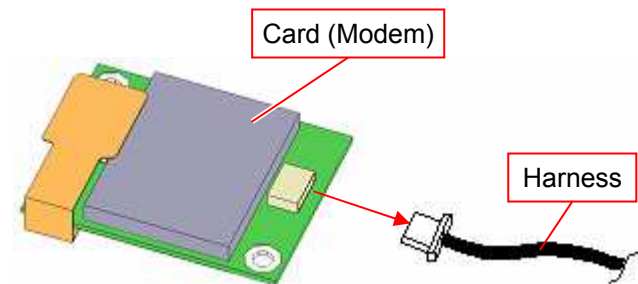

Turn over the Card (Modem), and disconnect the Harness.

# Parts of the Card (Modem)

1)

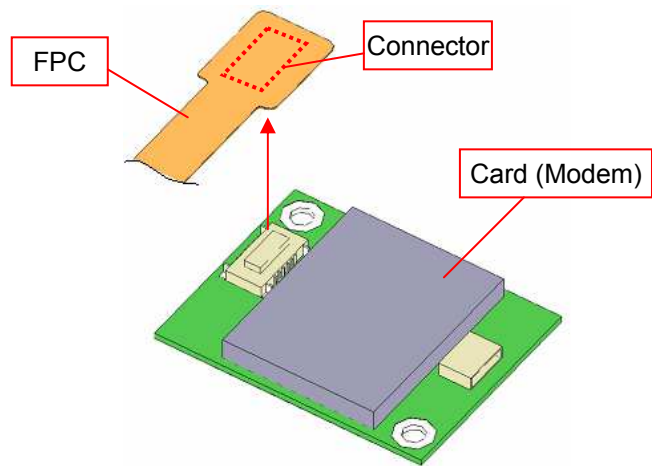

Disconnect the FPC.

# CNX-349 Board

1)

Filament Tape

Shield Tape (C)

△ [ADD]

Peel off the Filament Tape (two places) and the Shield Tape (C).

2)

Screw: B5

Remove the two screws.

3)

CNX Board

Connector

Escutcheon (R)

While removing the connector portion from the Escutcheon (R), remove the CNX Board.

4)

CNX Board

FPC

Lock Lever

Raise the lock lever to release the lock, and disconnect the FPC.

# Escutcheon (R)

1)

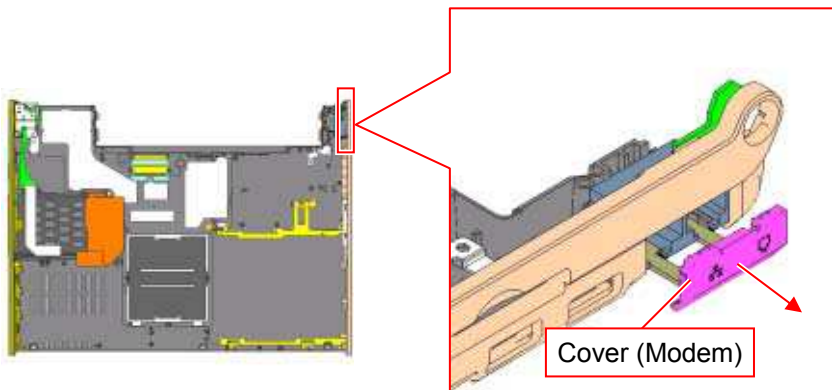

Pull out the Cover (Modem).

2)

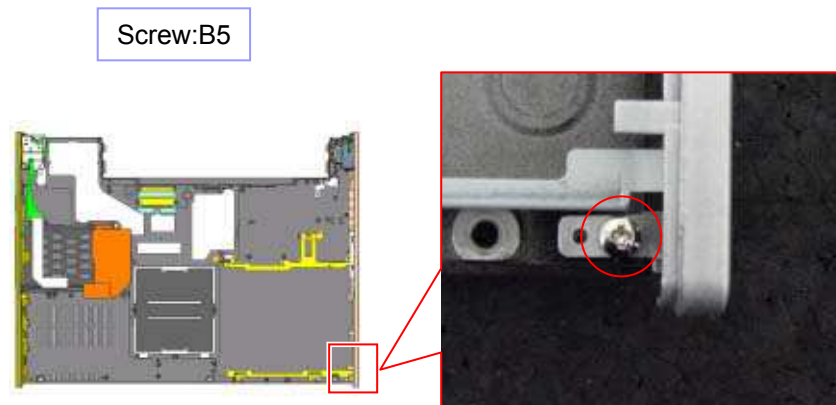

Remove the one screw.

3)

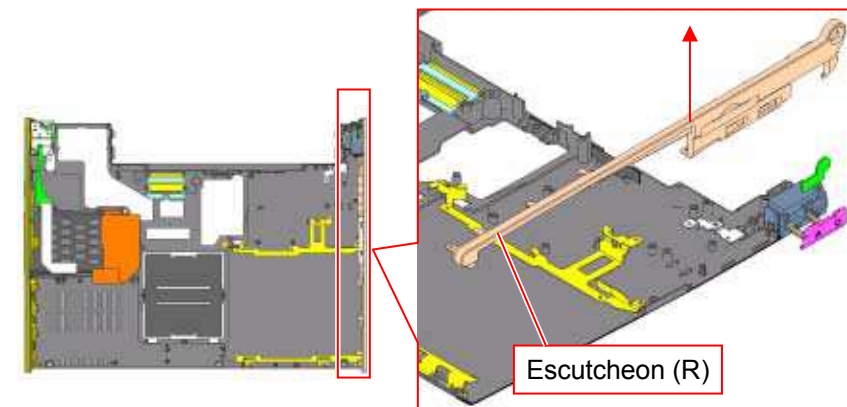

Remove the Escutcheon (R).

# WAN Antenna (Base Unit)

**WAN Model**

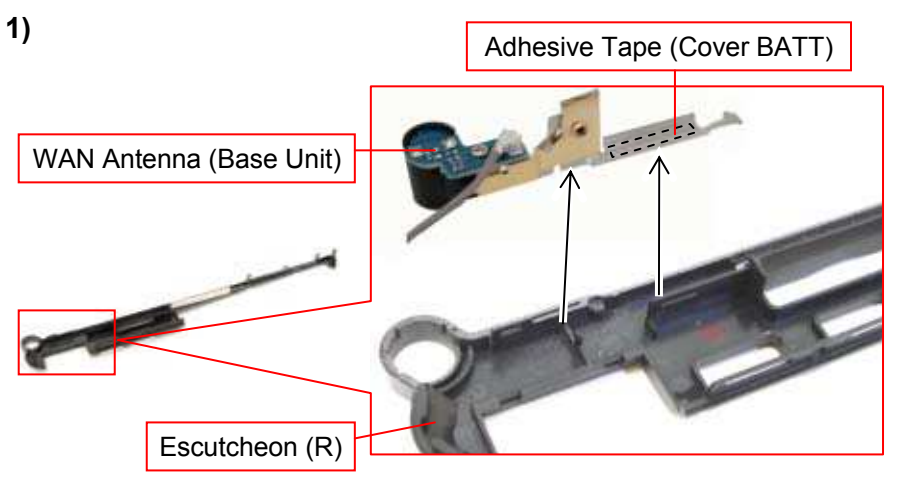

Remove the WAN Antenna (Base Unit).  
 \*The Adhesive Tape (Cover BATT) is attached on the bottom of it.

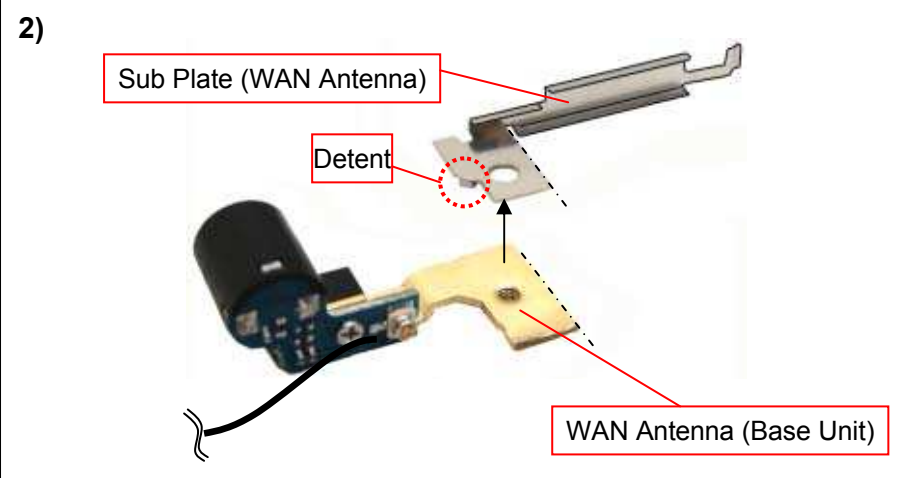

Remove the Sub Plate (WAN Antenna) while disengaging the detent (one place).

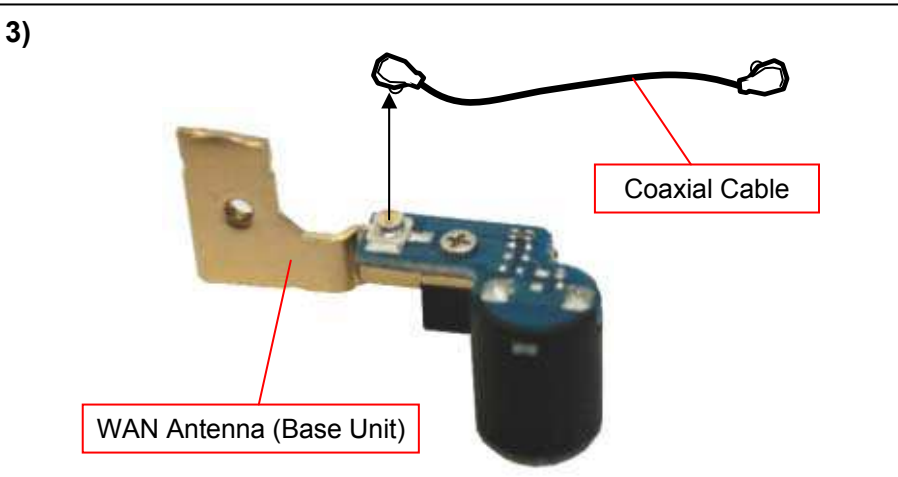

Disconnect the coaxial cable.  
 \* Disconnect the coaxial cable **vertically**.

# Harness (DC), Harness (RJ45/11), Cover (Modem)

1)  [ADD]

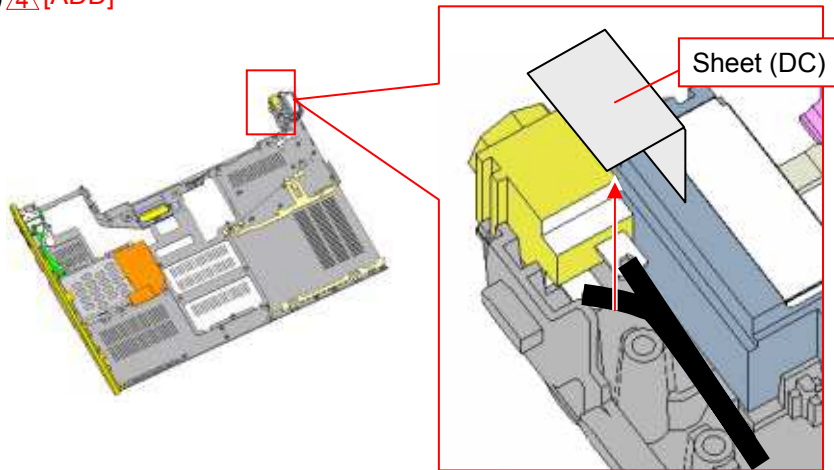

Peel off the Sheet (DC).

2)

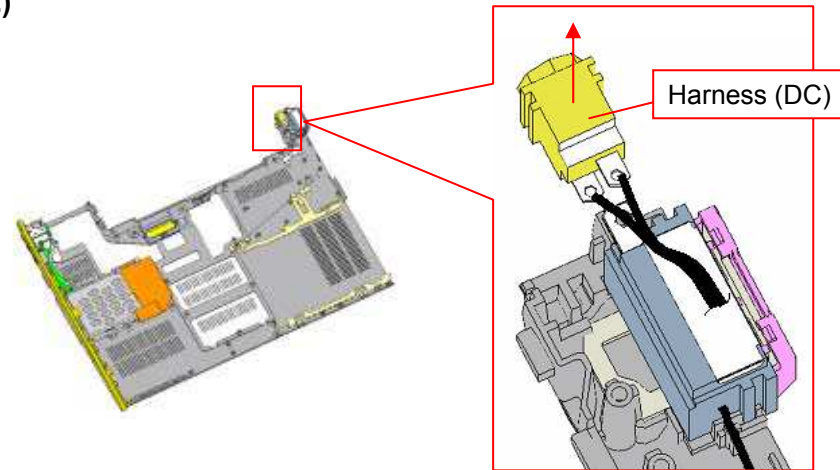

Remove the Harness (DC) by lifting it up vertically.

3)

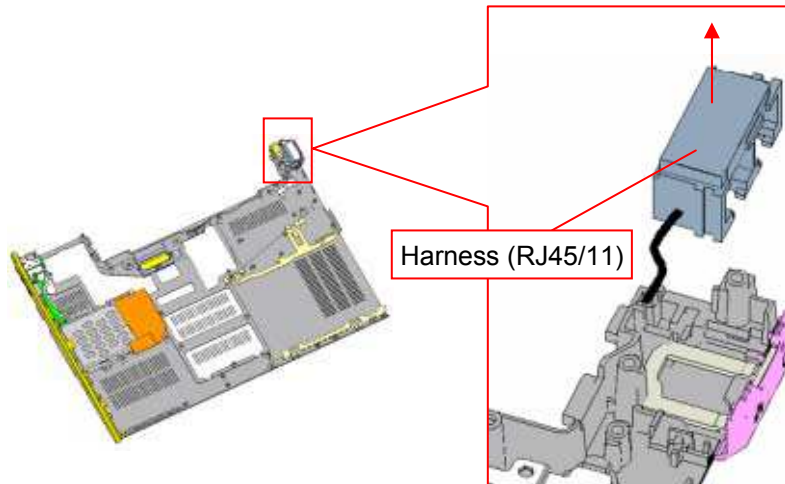

Remove the Harness (RJ45/11) by lifting it up vertically.

4)

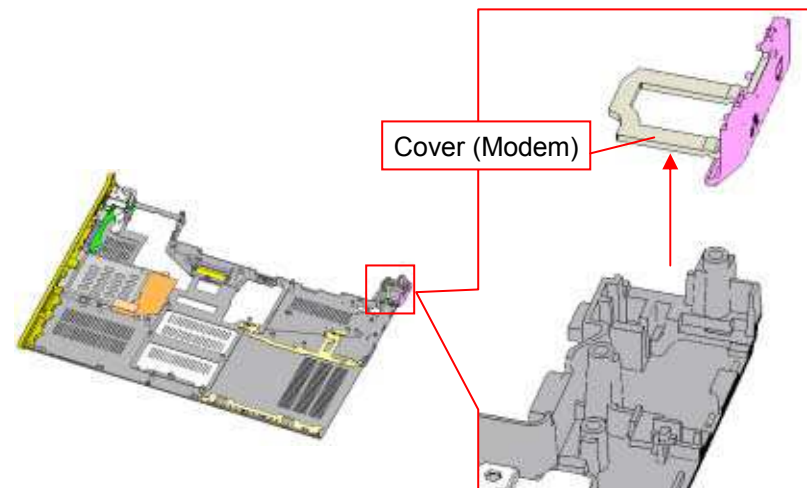

Remove the Cover (Modem).

# CNX-348 Board

1)

Screw: Red-B8 / Blue-B5

Gasket

Peel off the Gasket, and remove the three screws.

2)

Bracket (Dock-L)

Remove the Bracket (Dock-L).

3)

FPC

Pull out the FPC vertically.

4)

Connector

CNX Board

Escutcheon (L)

Remove the CNX Board while removing the connector portion from the Escutcheon (L).



# Parts of the CNX-348 Board

1)

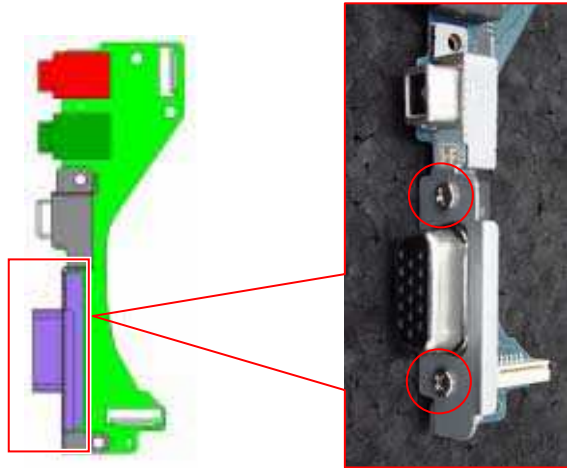

Screw: B6

Remove the two screws.

2)

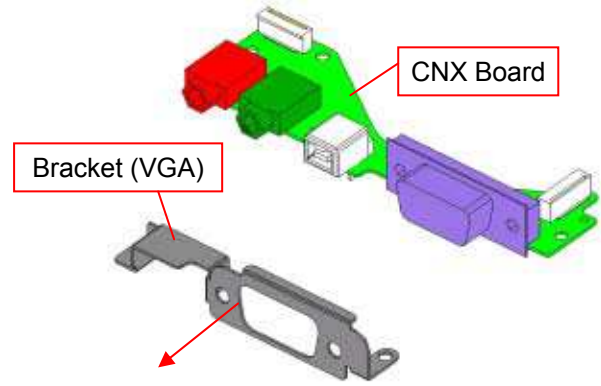

Remove the Bracket (VGA).

# Escutcheon (L)

1)

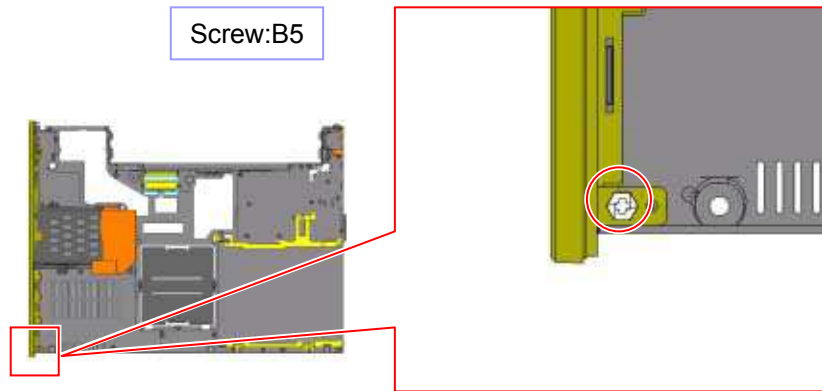

Remove the one screw.

2)

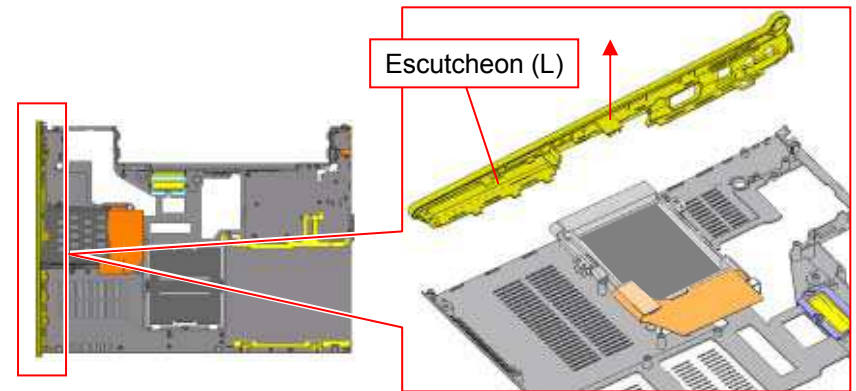

Remove the Escutcheon (L).

3)

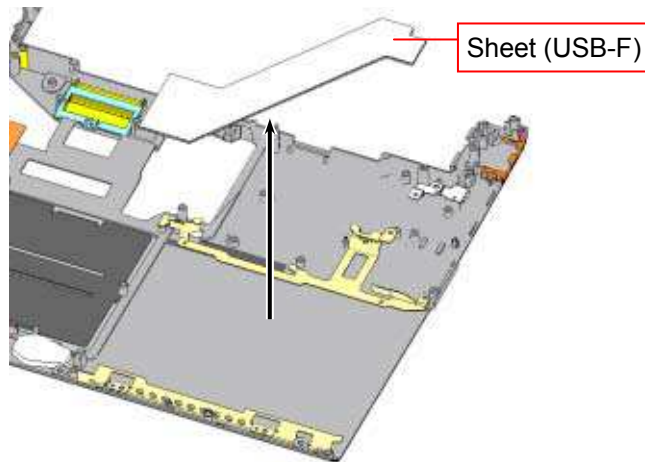

Peel off the Sheet (USB-F).

# PC Card Connector

1)

Sheet (PCMCIA)

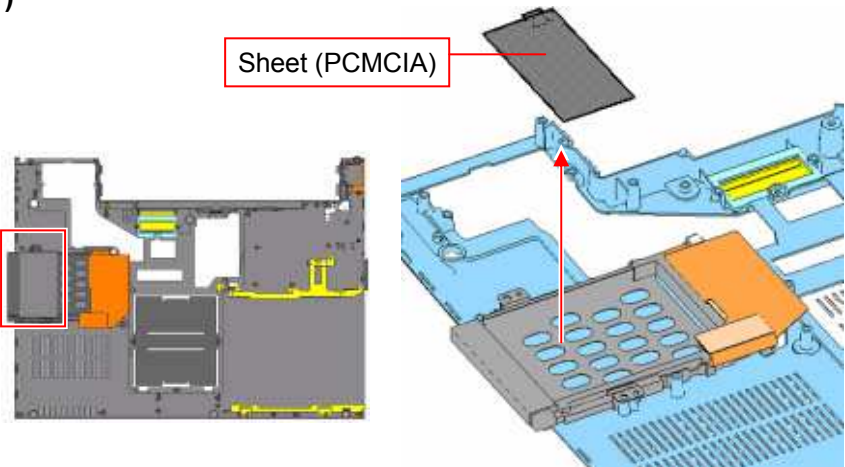

Peel off the Sheet (PCMCIA).

2)

Screw: B5

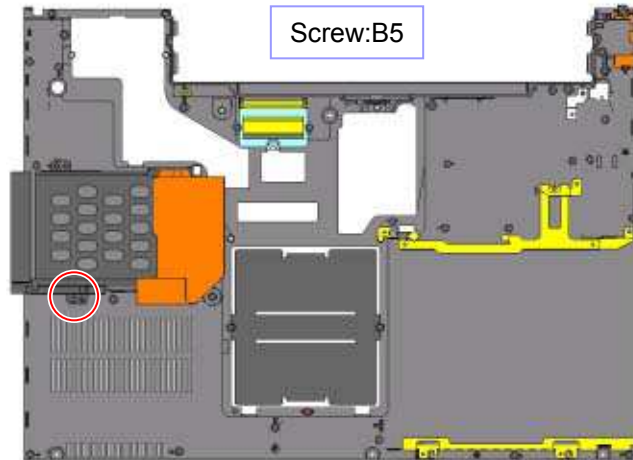

Remove the screw.

3)

PC Card Connector

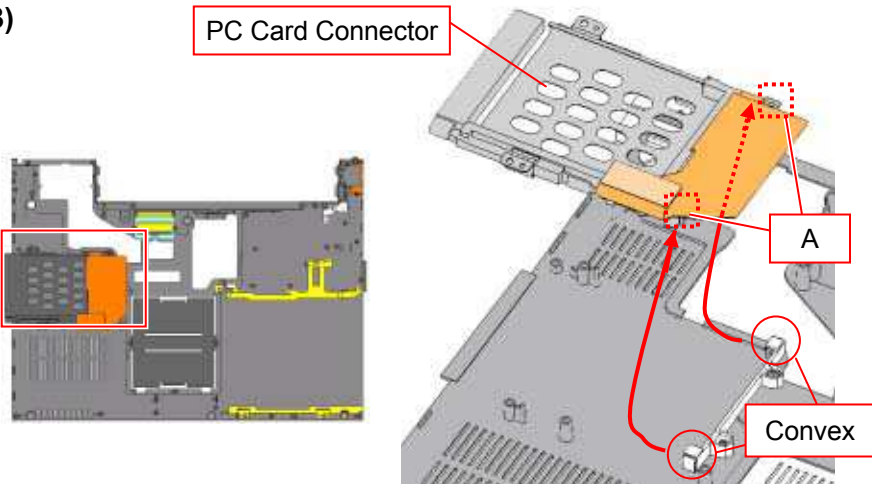

Remove the PC Card Connector while removing the A portion (two places) from the convex portion (two places).

## Parts of the PC Card Connector

1)

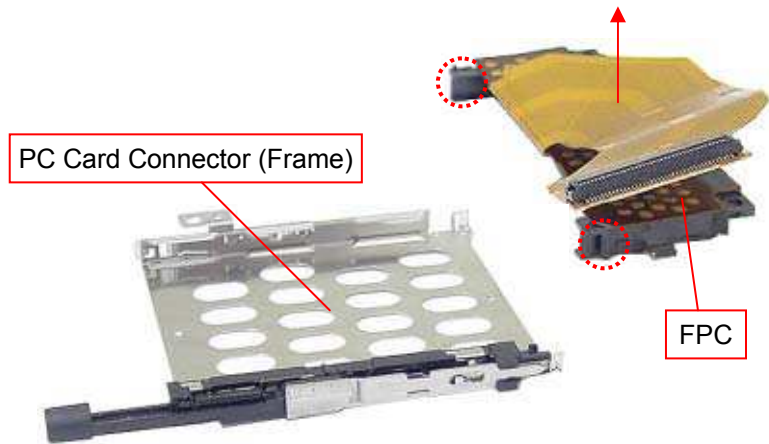

Remove the FPC while disengaging the detent (two places).

## Parts of the Housing (Bottom)

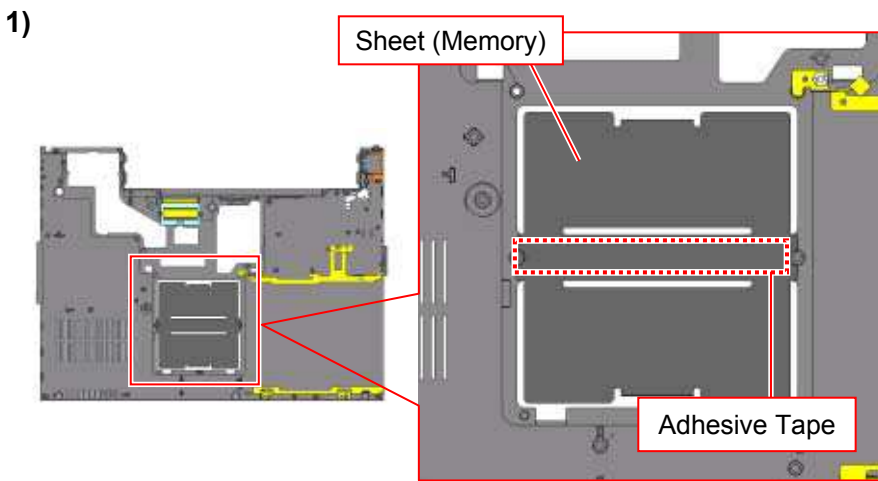

Peel off the Sheet (Memory).

\* The adhesive tape is attached on the bottom of it.

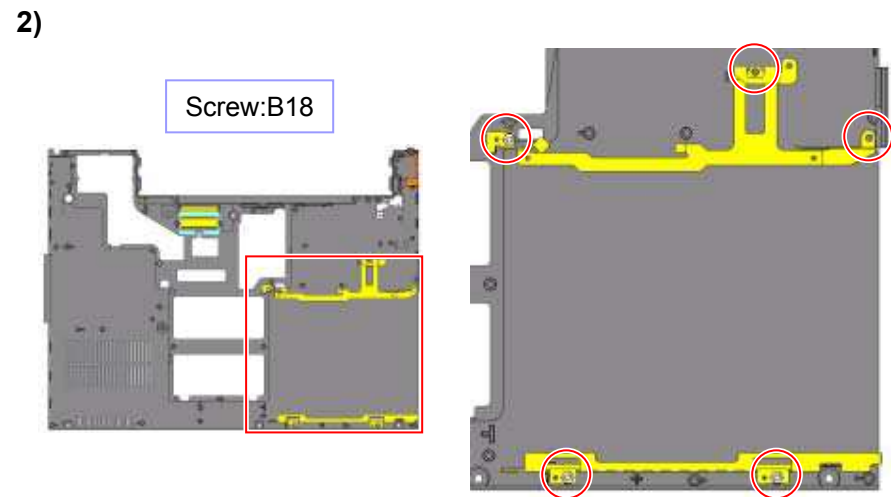

Remove the five screws.

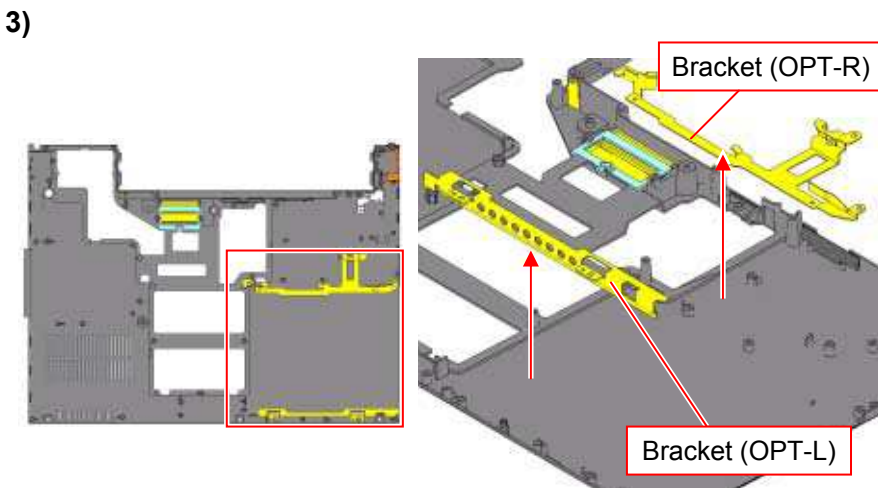

Remove the Bracket (two places).

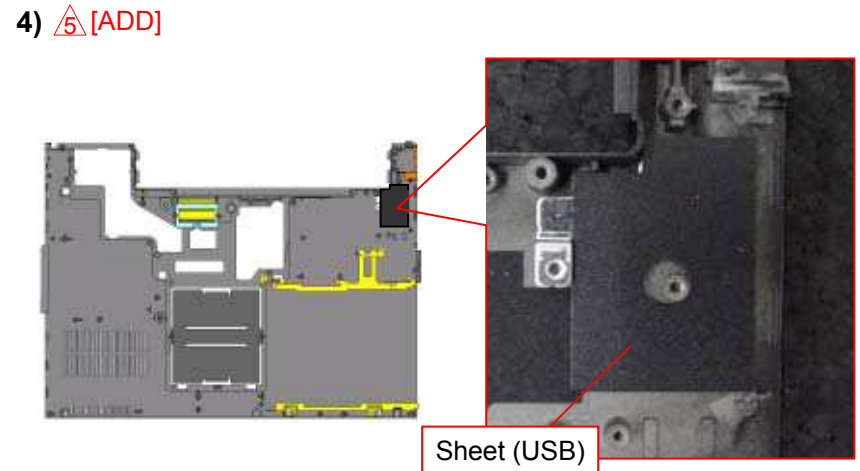

Remove the Sheet (USB).

## Update History

[ADD]---Addition [DEL]---Deletion [CHG]---Change [COR]---Correction [MA]---Model Addition

Date		Contents	Version No.
2006.02.27	△1	[CHG] Description (Page 13) [COR] Attachment (Page 13)	1.10
2006.03.28	△3	[ADD] Point (Page 7) / Attachment (Page 15, 29)	1.30
2006.04.13	△4	[MA] Parts (Page 2(a), 7, 24, 29, 30(a), 30(b), 34(a)) [ADD] Attachment (Page 35) [COR] Description (Page 29)	1.40
2006.04.26	△5	[ADD] Logo of Model Specification (Page 17) / Parts (Page 41)	2.00
2006.07.06	△8	[CHG] Attachment (Page 18) / Screw (Page 22)	2.30
2006.08.23	△9	[ADD] Attachment (Page 33)	3.00
2006.10.04	△11	[ADD] Screw (Page 30)	3.20