

Service Manual

Simplified

Notebook Computer

Model No. **CF-30KTPAXxM**

TOUGHBOOK

This is the Service Manual for
the following areas.
M ...for U.S.A. and Canada

 **WARNING**

This service information is designed for experienced repair technicians only and is not designed for use by the general public. It does not contain warnings or cautions to advise non-technical individuals of potential dangers in attempting to service a product. Products powered by electricity should be serviced or repaired only by experienced professional technicians. Any attempt to service or repair the product or products dealt with in this service information by anyone else could result in serious injury or death.

Panasonic[®]

© Panasonic Corporation 2008.
Unauthorized copying and distribution is a violation of law.

WARNING

For U.K.

This apparatus must be earthed for your safety.

To ensure safe operation the three-pin plug must be inserted only into a standard three-pin power point which is effectively earthed through the normal household wiring.

Extension cords used with the equipment must be three-core and be correctly wired to provide connection to earth. Wrongly wired extension cords are a major cause of fatalities.

The fact that the equipment operates satisfactorily does not imply that the power point is earthed and that the installation is completely safe.

For your safety, if you have any doubt about the effective earthing of the power point, consult a qualified electrician.

FOR YOUR SAFETY PLEASE READ THE FOLLOWING TEXT CAREFULLY

This appliance is supplied with a moulded three pin mains plug for your safety and convenience.

A 3 amp fuse is fitted in this plug.

Should the fuse need to be replaced please ensure that the replacement fuse has a rating of 3 amps and that it is approved by ASTA or BSI to BS 1362.

Check for the ASTA mark  or the BSI mark  on the body of the fuse.

If the plug contains a removable fuse cover you must ensure that it is refitted when the fuse is replaced.

If you lose the fuse cover the plug must not be used until a replacement cover is obtained.

A replacement fuse cover can be purchased from your local Panasonic Dealer.

IF THE FITTED MOULDED PLUG IS UNSUITABLE FOR THE SOCKET OUTLET IN YOUR HOME THEN THE FUSE SHOULD BE REMOVED AND THE PLUG CUT OFF AND DISPOSED OF SAFELY.

THERE IS A DANGER OF SEVERE ELECTRICAL SHOCK IF THE CUT OFF PLUG IS INSERTED INTO ANY 13 AMP SOCKET.

If a new plug is to be fitted please observe the wiring code as shown below.

If in any doubt please consult a qualified electrician.

Warning: THIS APPLIANCE MUST BE EARTHED.

Important

The wires in this mains lead are coloured in accordance with the following code:

Green-and-yellow:	Earth
Blue:	Neutral
Brown:	Live

As the colours of the wires in the mains lead of this apparatus may not correspond with the coloured markings identifying the terminals in your plug, proceed as follows:

The wire which is coloured GREEN-and-YELLOW must be connected to the terminal in the plug which is marked by the letter E or by the safety earth symbol  coloured GREEN or GREEN-and-YELLOW.

The wire which is coloured Blue must be connected to the terminal which is marked with the letter N or coloured BLACK.

The wire which is coloured Brown must be connected to the terminal which is marked with the letter L or coloured RED.

The mains plug on this equipment must be used to disconnect the mains power.

Please ensure that a socket outlet is available near the equipment and shall be easily accessible.

How to replace the fuse

Open the fuse compartment with a screwdriver and replace the fuse.

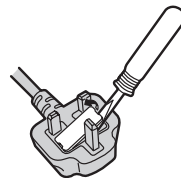

Warnings

- This equipment is not designed for connection to an IT power system.
(An IT system is a system having no direct connections between live parts and Earth; the exposed-conductive-parts of the electrical installation are earthed.
An IT system is not permitted where the computer is directly connected to public supply systems in the U.K.)
- Disconnect the mains plug from the supply socket when the computer is not in use.

This equipment is produced to BS800/1983.

LASER SAFETY INFORMATION

For U.S.A.

Class 1 LASER-Product

This product is certified to comply with DHHS Rules 21 CFR Subchapter J.

This product complies with European Standard EN60825 (or IEC Publication 825)

For all areas

This equipment is classified as a class 1 level LASER product and there is no hazardous LASER radiation.

Caution:

- (1) Use of controls or adjustments or performance of procedures other than those specified herein may result in hazardous radiation exposure.
- (2) The drive is designed to be incorporated into a computer-based system or unit which has an enclosing cover. It should never be used as a stand alone drive.

Danger:

The serviceman should not remove the cover of drive unit and should not service because the drive unit is a nonserviceable part.
Please check DANGER label on PD-drive unit.

- Unplug the AC power cord to the equipment before opening the top cover of the drive.
When the power switch it on, do not place your eyes close to the front panel door to look into the interior of the unit.

LASER Specification

Class 1 level LASER Product

Wave Length: DVD 658±8 nm

CD 775~815 nm

Laser safety information is appropriate only when drive with laser is installed.

SAFETY PRECAUTIONS

1. Before servicing, unplug the power cord to prevent an electric shock.
2. When replacing parts, use only manufacturer's recommended components for safety.
3. Check the condition of the power cord. Replace if wear or damage is evident.
4. After servicing, be sure to restore the lead dress, insulation barriers, insulation papers, shields, etc.

Important Safety Instructions

When using your telephone equipment, basic safety precautions should always be followed to reduce the risk of fire, electric shock and injury to persons, including the following:

1. Do not use this product near water, for example, near a bath tub, wash bowl, kitchen sink or laundry tub, in a wet basement or near a swimming pool.
2. Avoid using a telephone (other than a cordless type) during an electrical storm. There may be a remote risk of electric shock from lightning.
3. Do not use the telephone to report a gas leak in the vicinity of the leak.
4. Use only the power cord and batteries indicated in this manual. Do not dispose of batteries in a fire. They may explode. Check with local codes for possible special disposal instructions.

SAVE THESE INSTRUCTIONS

LITHIUM BATTERY

This computer contains a lithium battery to enable the date, time, and other data to be stored. The battery should only be exchanged by authorized service personnel.

Warning! A risk of explosion from incorrect installation or misapplication may possibly occur.

LITHIUM BATTERY ⚠

• CAUTION

Danger of explosion if battery is incorrectly replaced.

Replace only with the same or equivalent type battery recommended by the manufacturer.

Dispose of used batteries according to the manufacturer's instructions.

LITHIUMBATTERIES ⚠

Vorsicht!

Explosionsgefahr bei unsachgemäßem Austausch der Batterie. Ersatz nur durch denselben oder einen vom Hersteller empfohlenen ähnlichen Typ. Entsorgung gebrauchter Batterien nach Angaben des Herstellers.

PILE AU LITHIUM ⚠

ATTENTION: IL Y A DANGER D'EXPLOSION S' IL Y A REMPLACEMENT INCORRECT DE LA PILE. REMPLACER UNIQUEMENT AVEC UNE PILE DU MÊME TYPE OU D'UN TYPE RECOMMANDÉ PAR LE CONSTRUCTEUR. METTRE AU RÉBUT LES PILES USAGÉES CONFORMÉMENT AUX INSTRUCTIONS DU FABRICANT.

Precautions (Battery Pack)

Do Not Use with Any Other Product

The battery pack is rechargeable and was intended for the specified product. If it is used with a product other than the one for which it was designed, electrolyte leakage, generation of heat, ignition or rupture may result.

Do Not Charge the Battery Using Methods Other Than Those Specified

If the battery is not charged using one of the specified methods, electrolyte leakage, generation of heat, ignition or rupture may result.

Do Not Throw the Battery Pack into a Fire or Expose It to Excessive Heat

Generation of heat, ignition or rupture may result.

Avoid Extreme Heat (Near the Fire, in Direct Sunlight, for Example)

Electrolyte leakage, generation of heat, ignition or rupture may result.

Do Not Insert Sharp Objects into the Battery Pack, Expose It to Bumps or Shocks, Disassemble, or Modify It

Electrolyte leakage, generation of heat, ignition or rupture may result.

Do Not Short the Positive (+) and Negative (-) Contacts

Generation of heat, ignition or rupture may result. Do not place the battery pack together with articles such as necklaces or hairpins when carrying or storing.

Do Not Use This Product with a Battery Pack Other Than the One Specified

Use only the specified battery pack with your product. Use of battery packs other than those manufactured and supplied by Panasonic may present a safety hazard (generation of heat, ignition or rupture).



A lithium ion battery that is recyclable powers the product you have purchased.

Please call 1-800-8-BATTERY for information on how to recycle this battery.

L'appareil que vous vous êtes procuré est alimenté par une batterie au lithium-ion.

Pour des renseignements sur le recyclage de la batterie, veuillez composer le 1-800-8-BATTERY.

When the Battery Pack Has Become Degraded, Replace It with a New One

Continued use of a degraded battery pack may generate high levels of heat, cause a fire to start and cause the pack to burst or explode.

- Do not touch the terminals on the battery pack. The battery pack may no longer function properly if the contacts are dirty or damaged.
- Do not expose the battery pack to water, or allow it to become wet.
- If the battery pack will not be used for a long period of time (a month or more), charge or discharge (use) the battery pack until the remaining battery level becomes 30% to 40% and store it in a cool, dry place.
- This computer prevents overcharging of the battery by recharging only when the remaining power is less than approx. 95% (when Economy Mode (ECO) is enabled: 75%) of capacity.
- The battery pack is not charged when the computer is first purchased. Be sure to charge it before using it for the first time. When the AC adaptor is connected to the computer, charging begins automatically.
- Should the battery leak and the fluid get into your eyes, do not rub your eyes. Immediately flush your eyes with clear water and see a doctor for medical treatment as soon as possible.

NOTE

- The battery pack may become warm during recharging or normal use. This is completely normal.
- Recharging will not commence if internal temperature of the battery pack is outside of the allowable temperature range (0 °C to 55 °C {32 °F to 131 °F}). (→  Reference Manual "Battery Power") Once the allowable range requirement is satisfied, charging begins automatically. Note that the recharging time varies based on the usage conditions. (Recharging takes longer than usual when the temperature is 10 °C {50 °F} or below.)
- If the temperature is low, the operating time is shortened. Only use the computer within the allowable temperature range.
- The battery pack is a consumable item. If the amount of time the computer can be run by using a particular battery pack becomes dramatically shorter and repeated recharging does not restore its performance, the battery pack should be replaced with a new one.
- When transporting a spare battery inside a package, briefcase, etc., it is recommended that it be placed in a plastic bag so that its contacts are protected.
- Always power off the computer when it is not in use. Leaving the computer on when the AC adaptor is not connected will exhaust the remaining battery capacity.

CONTENTS

1. Specifications	1-1
2. Names and Functions of Parts.....	2-1
3. Block Diagram	3-1
4. Diagnosis Procedure	4-1
5. Power-On Self Test (Boot Check).....	5-1
6. List of Error Codes <Only when the port replicator is connected>	6-1
7. Self Diagnosis Test	7-1
8. Wiring Connection Diagram	8-1
9. Disassembly/Reassembly	9-1
10. Exploded View	10-1
11. Replacement Parts List	11-1

1. Specifications

This page provides the specifications for the basic model.
The model number is different according to the unit configuration.

- To check the model number:
Check the bottom of the computer or the box the computer came in at the time of purchase.
- To check CPU speed, memory size and the hard disk drive (HDD) size:
Run the Setup Utility (→  *Reference Manual* "Setup Utility") and select [Information] menu.
[CPU Speed]: CPU speed, [System Memory]: Memory size, [Hard Disk]: Hard disk drive size

■ Main Specifications

Model No.	CF-30KTPAXJM		CF-30K3PAXAM
CPU	Intel® Core™ 2 Duo Processor SL9300 (1.6 GHz, 6 MB ⁻¹ L2 cache, 1066 MHz FSB)		
Chipset	Mobile Intel® GS45 Express Chipset		
Memory ^{*1,2}	2 GB (4 GB Max.)		
Video Memory ^{*1,3}	UMA 797 MB Max. (When Memory is 2 GB)/ 1551 MB Max. (When Memory is 4 GB)	1 GB Max.	
Hard Disk Drive ^{*4}	160 GB Approx. 2 GB is used as a partition with recovery tools. (Users cannot use this partition.)		
Display Method	13.3 XGA type (TFT) with Touchscreen	13.3 XGA type (TFT)	
Internal LCD ^{*5}	65,536/16,777,216 colors (800 × 600 dots/1024 × 768 dots)		
External Display ^{*6}	65,536/16,777,216 colors (800 × 600 dots/1024 × 768 dots/1280 × 768 dots/1280 × 1024 dots/1440 × 900 dots)		
Wireless LAN ^{*7}	→ Next page		
Bluetooth™ ^{*8}	→ Next page		
LAN	IEEE 802.3 10BASE-T, IEEE 802.3u 100BASE-TX, IEEE 802.3ab 1000BASE-T		
Modem	Data: 56 kbps (V.92) FAX: 14.4 kbps		
Sound	WAVE and MIDI playback, Intel® High Definition Audio subsystem support, Monaural speaker		
Security Chip	TPM (TCG V1.2 compliant) ^{*9}		
Card Slot	PC Card	Type I or Type II x 1 (3.3 V: 400 mA, 5 V: 400 mA)	
	ExpressCard	ExpressCard/34 or ExpressCard/54 x 1	
	SD Memory Card ^{*10}	x 1, Data transfer rate = 8 MB per second ^{*11}	
	Smart Card ^{*12}	ISO7816 x 1	
RAM Module Slot	200-pin, 1.8 V, SO-DIMM, DDR2 SDRAM, PC2-5300 Compliant		
Interface	USB port (4-pin, USB 2.0) x 3, Serial port (Dsub 9-pin male), Modem port (RJ-11), LAN port (RJ-45), External display port (Mini Dsub 15-pin female), Expansion Bus Connector (Dedicated 80-pin female), External Antenna Connector (Dedicated 50 Ω coaxial connector), IEEE 1394a Interface Connector (4-pin x 1), Microphone Jack (Miniature jack, 3.5 DIA, Stereo), Headphone Jack (Miniature jack, 3.5 DIA, Impedance 32 Ω, Output Power 4 mW x 2)		
Keyboard / Pointing Device	87 keys / Touch Pad / Touchscreen (Anti-Reflection, Stylus (included) touch capable)	87 keys / Touch Pad	
Power Supply	AC adaptor or Battery pack		
AC Adaptor ^{*13}	Input: 100 V to 240 V AC, 50 Hz/60 Hz, Output: 15.6 V DC, 5.0 A		
Battery Pack	Li-ion 10.65 V, 8.55 Ah		
Operating Time ^{*14}	Main Battery: Approx. 9 hours ^{*15} Main Battery + Second Battery: Approx. 12.5 hours ^{*15}		Main Battery: Approx. 10 hours ^{*15} Main Battery + Second Battery: Approx. 14 hours ^{*15}
	Charging Time ^{*14}	Power on	Main Battery: Approx. 8.5 hours Main Battery + Second Battery: Approx. 12.5 hours
Power off		Main Battery: Approx. 5 hours Main Battery + Second Battery: Approx. 8 hours	
Clock Battery	Coin type lithium battery 3.0 V		
Power Consumption ^{*16}	Approx. 50 W ^{*17} / Approx. 70 W (maximum when recharging in the ON state)		
Physical Dimensions (W × H × D)	302 mm × 67.5 - 69.5 mm × 292 mm {11.9" × 2.7 - 2.8" × 11.5"}		

■ Main Specifications

Weight	Approx. 3.8 kg {Approx. 8.4 lb.}, excluding the dummy pack and dummy cards (Approx. 50g {Approx. 1.8 oz.})
Operation Environment	Temperature: 5 °C to 35 °C {41 °F to 95 °F} Humidity: 30% to 80% RH (No condensation)
Storage Environment	Temperature: -20 °C to 60 °C {-4 °F to 140 °F} Humidity: 30% to 90% RH (No condensation)
Operating System	Windows Vista Windows Vista® Business Service Pack 1 Windows XP Microsoft® Windows® XP Professional Service Pack 2 with Advanced Security Technologies (NTFS File System)
Utility Programs	Adobe Reader, PC Information Viewer, Loupe Utility, Intel® PROSet/Wireless Software ¹⁷ , Bluetooth™ Stack for Windows® by TOSHIBA ⁸ , Wireless Switch Utility, Hotkey Settings, Battery Recalibration Utility, Panasonic Hand Writing, Infineon TPM Professional Package ¹⁸ , Power Saving Utility, Wireless Connection Disable Utility ¹⁸ , Concealed mode Utility ¹⁹ . Setup Utility, Hard Disk Data Erase Utility ²⁰ , PC-Diagnostic Utility

■ Wireless LAN <Only for model with wireless LAN>

Data Transfer Rates	IEEE802.11a : 54/48/36/24/18/12/9/6 Mbps (automatically switched) ²¹ IEEE802.11b : 11/5.5/2/1 Mbps (automatically switched) ²¹ IEEE802.11g : 54/48/36/24/18/12/9/6 Mbps (automatically switched) ²¹ IEEE802.11n : (HT20) 144.4/130/117/115.6/104/86.7/78/65/58.5/57.8/52/43.3/39/28.926/19.5/ 14.4/13/6.5 Mbps (automatically switched) ²¹ (HT40) 300/270/243/240/216/180/162/130/120/117/108/104/90/81/78/60/54/52/ 39/30/27/26/13 Mbps (automatically switched) ²¹
Standards Supported	IEEE802.11a / IEEE802.11b / IEEE802.11g / IEEE802.11n(Draft 2.0)
Transmission method	OFDM system, DSSS system
Wireless Channels Used	IEEE802.11a : Channels 36/40/44/48/52/56/60/64/100/104/108/112/116/132/136/140/149/153/ 157/161/165 IEEE802.11b/IEEE802.11g : Channels 1 to 11 IEEE802.11n : Channels 1-11/36/40/44/48/52/56/60/64/100/104/108/112/116/132/136/140/149/ 153/157/161/165
RF Frequency Band	IEEE802.11a : 5.18 GHz - 5.32 GHz, 5.5 GHz - 5.58 GHz, 5.66 GHz - 5.7 GHz, 5.745 GHz - 5.825 GHz IEEE802.11b/IEEE802.11g : 2.412 GHz - 2.462 GHz IEEE802.11n : 2.412 GHz - 2.462 GHz, 5.15 GHz - 5.35 GHz, 5.5 GHz - 5.58 GHz, 5.66 GHz - 5.7 GHz, 5.745 GHz - 5.85 GHz

■ Bluetooth™ <Only for model with Bluetooth>

Bluetooth Version	2.0 + EDR
Transmission method	FHSS system
Wireless Channels Used	Channels 1 to 79
RF Frequency Band	2.402-2.48 GHz

¹ 1 MB = 1,048,576 bytes / 1 GB = 1,073,741,824 bytes

² You can physically expand the memory up to 4096 MB, but the total amount of usable memory available will be less depending on the actual system configuration.

³ A segment of the main memory is allotted automatically depending on the computer's operating status. The size of the Video Memory cannot be set by the user.

⁴ 1 GB = 1,000,000,000 bytes. Your operating system or some application software will report as fewer GB.

⁵ A 16,777,216 color display is achieved by using the dithering function.

⁶ Maximum resolution depends on the specifications of the external display. Display may be impossible using some connected external displays.

⁷ Only for model with wireless LAN

⁸ Only for model with Bluetooth

⁹ For information on TPM, **Windows Vista** click  (Start) and input "c:\util\drivers\tpm\README.pdf" in [Start Search] and press **Enter**, and refer to the Installation Manual of "Trusted Platform Module (TPM)".

Windows XP click [start] - [Run] and input "c:\util\drivers\tpm\README.pdf", and refer to the Installation Manual of "Trusted Platform Module (TPM)".

¹⁰ SD Memory Cards that support high-speed transfer rates can be used. **Windows Vista** Windows ReadyBoost function is also supported.

Operation has been tested and confirmed using Panasonic SD Memory Cards and SDHC Memory Cards with a capacity of up to 8 GB. Operation on other SD equipment is not guaranteed.

This computer is not compatible with MultiMediaCards. Do not insert these kinds of cards.

¹¹ The theoretical value is not the actual speed. The transfer rate does not become higher even if you use a card that supports the higher transfer rate.

¹² Only for model with Smart Card slot

- ^{*13} <Only for North America>
The AC adaptor is compatible with power sources up to 240 V AC adaptor. The computer is supplied with a 125 V AC compatible AC cord. ^{20-M-2-1}
- ^{*14} Varies depending on the usage conditions.
- ^{*15} Measured at LCD brightness: 60 cd/m²
- ^{*16} Varies depending on the usage conditions, or when an external device is attached.
- ^{*17} Approx. 0.9 W when the battery pack is fully charged (or not being charged) and the computer is OFF.
- ^{*18} Rated power consumption ^{23-E-1}
You need to install to use the feature.
- ^{*19} Concealed Mode may not work properly during battery recalibration.
- ^{*20} The Product Recovery DVD-ROM is required.
- ^{*21} It does not correspond to IEEE802.11a+b+g+n standards. Actual speeds may differ.

2. Names and Functions of Parts

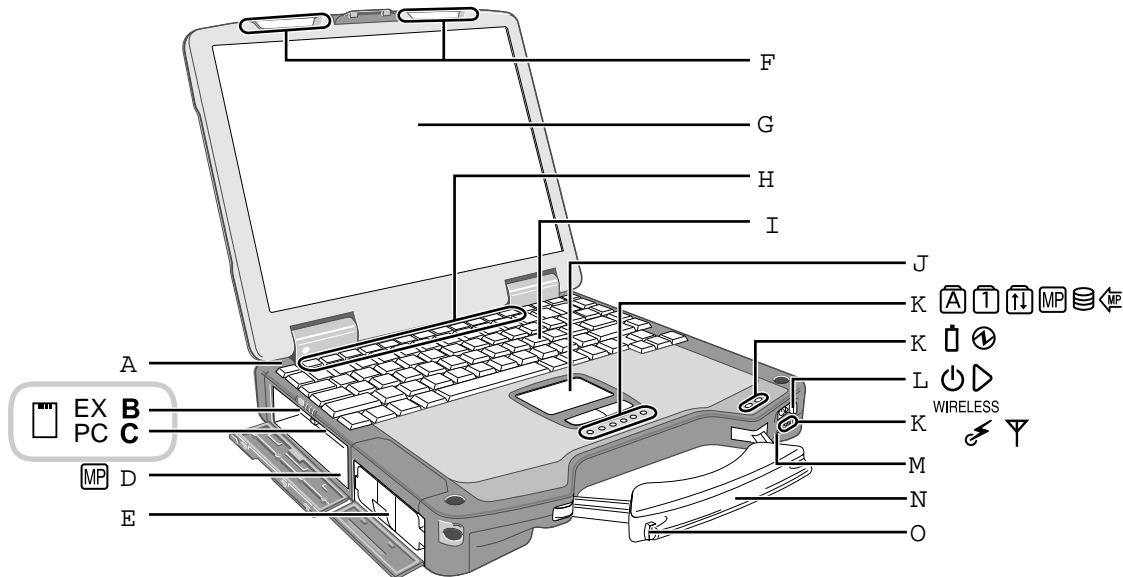

A: Bluetooth Antenna

<Only for model with Bluetooth>

Reference Manual "Bluetooth"

B: ExpressCard Slot

Reference Manual "PC Card / ExpressCard"

C: PC Card Slot

Reference Manual "PC Card / ExpressCard"

D: Multimedia Pocket

Reference Manual "Multimedia Pocket"

E: Battery Pack

Specified Battery pack: CF-VZSU46

F: Wireless LAN Antenna

<Only for model with wireless LAN>

Reference Manual "Wireless LAN"

G: LCD

<Only for model with touchscreen>

Reference Manual "Touchscreen"

H: Function Key

Reference Manual "Key Combinations"

I: Keyboard

J: Touch Pad

K: LED Indicator

: Caps lock

: Numeric key (NumLk)

: Scroll lock (ScrLk)

: Multimedia pocket device status or the second battery status

Reference Manual "Multimedia Pocket"
"Battery Power"

: Hard disk drive status

: Power status of the multimedia pocket

: Battery status

Reference Manual "Battery Power"

: Power status

(Off: Power off/Hibernation, Green: Power on, Blinking green: **Windows Vista** Sleep/**Windows XP** Standby, Blinking green rapidly: Cannot power on or resume due to low temperature.)

: Wireless ready

This indicator lights when Wireless LAN, Bluetooth, and/or Wireless WAN are connected and ready. It does not necessarily indicate the On/Off condition of the wireless connection.

Reference Manual "Wireless LAN" "Bluetooth" "Disabling/Enabling Wireless Communication"

: Wireless WAN status

<Only for model with wireless WAN>

Refer to the instruction manual of the wireless device

L: Power Switch

M: Wireless Switch

Reference Manual "Disabling/Enabling Wireless Communication"

N: Carrying Handle

O: Stylus Holder

Right side

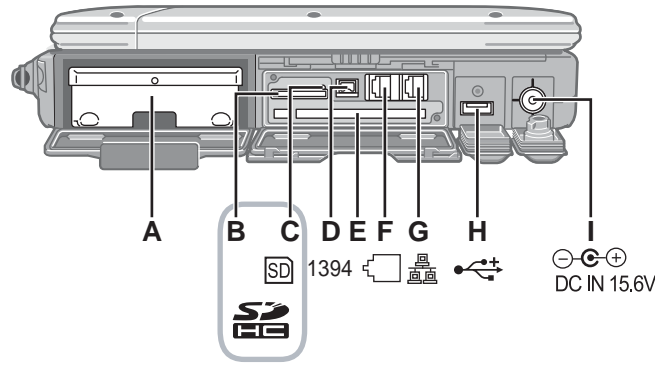

Rear side

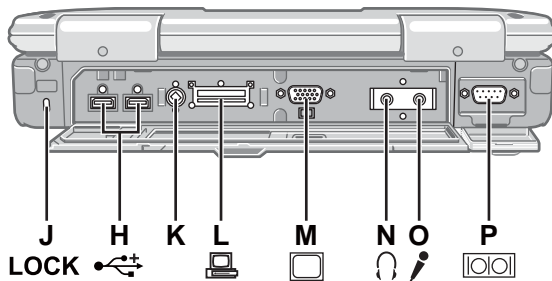

Bottom

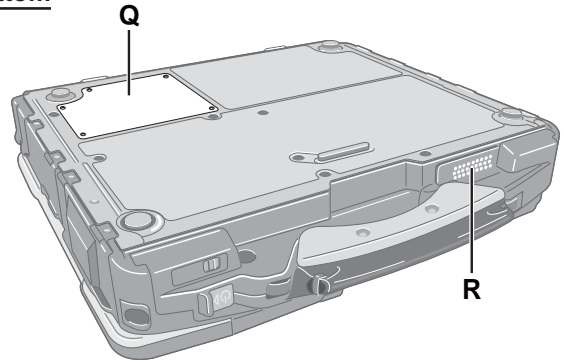

A: Hard Disk Drive

→ *Reference Manual* "Hard Disk Drive"

B: SD Memory Card Slot

→ *Reference Manual* "SD Memory Card"

C: SD Memory Card Indicator

(Blinking: During access)

→ *Reference Manual* "SD Memory Card"

D: IEEE 1394 Interface Connector

→ *Reference Manual* "IEEE 1394 Devices"

E: Smart Card Slot

<Only for model with Smart Card slot>

→ *Reference Manual* "Smart Card"

F: Modem Port

→ *Reference Manual* "Modem"

G: LAN Port

→ *Reference Manual* "LAN"

H: USB Port

→ *Reference Manual* "USB Devices"

I: DC-IN Jack

J: Security Lock

A Kensington cable can be connected.
For further information, read the manual that comes with the cable.

K: External Antenna Connector

L: Expansion Bus Connector

→ *Reference Manual* "Port Replicator / Car Mounter"

M: External Display Port

→ *Reference Manual* "External Display"

N: Headphone Jack

You can connect headphones or amplified speakers. When they are connected, audio from the internal speakers is not heard.

O: Microphone Jack

A condenser microphone can be used. other types of microphones are used, audio input may not be possible, or malfunctions may occur as a result.

- When recording in stereo using a stereo microphone:

Windows Vista

Click (Start) - [Control Panel] - [Hardware and Sound] - [Sound] - [Recording] - [Microphone] - [Properties], and then add a check mark for [No Audio Enhancements] in [Microphone Enhancements].

Windows XP

Click [start] - [All Programs] - [SoundMAX] - [Control Panel] and select [Microphone], and then add a check mark for [No Filtering] in [Microphone Enhancements].

- When using a monaural microphone with a 2-terminal plug:

Windows Vista

Click (Start) - [Control Panel] - [Hardware and Sound] - [Sound] - [Recording] - [Microphone] - [Properties], and then add a check mark for [Voice Enhancements] in [Microphone Enhancements]. Otherwise, only audio on the left track will be recorded.

Windows XP

Click [start] - [All Programs] - [SoundMAX] - [Control Panel] and select [Microphone], and then add a check mark for [Voice Recording] in [Microphone Enhancements]. Otherwise, only audio on the left track will be recorded.

P: Serial Port

Q: RAM Module Slot

→ *Reference Manual* "RAM Module"

R: Speaker

→ *Reference Manual* "Key Combinations"

3 Block Diagram

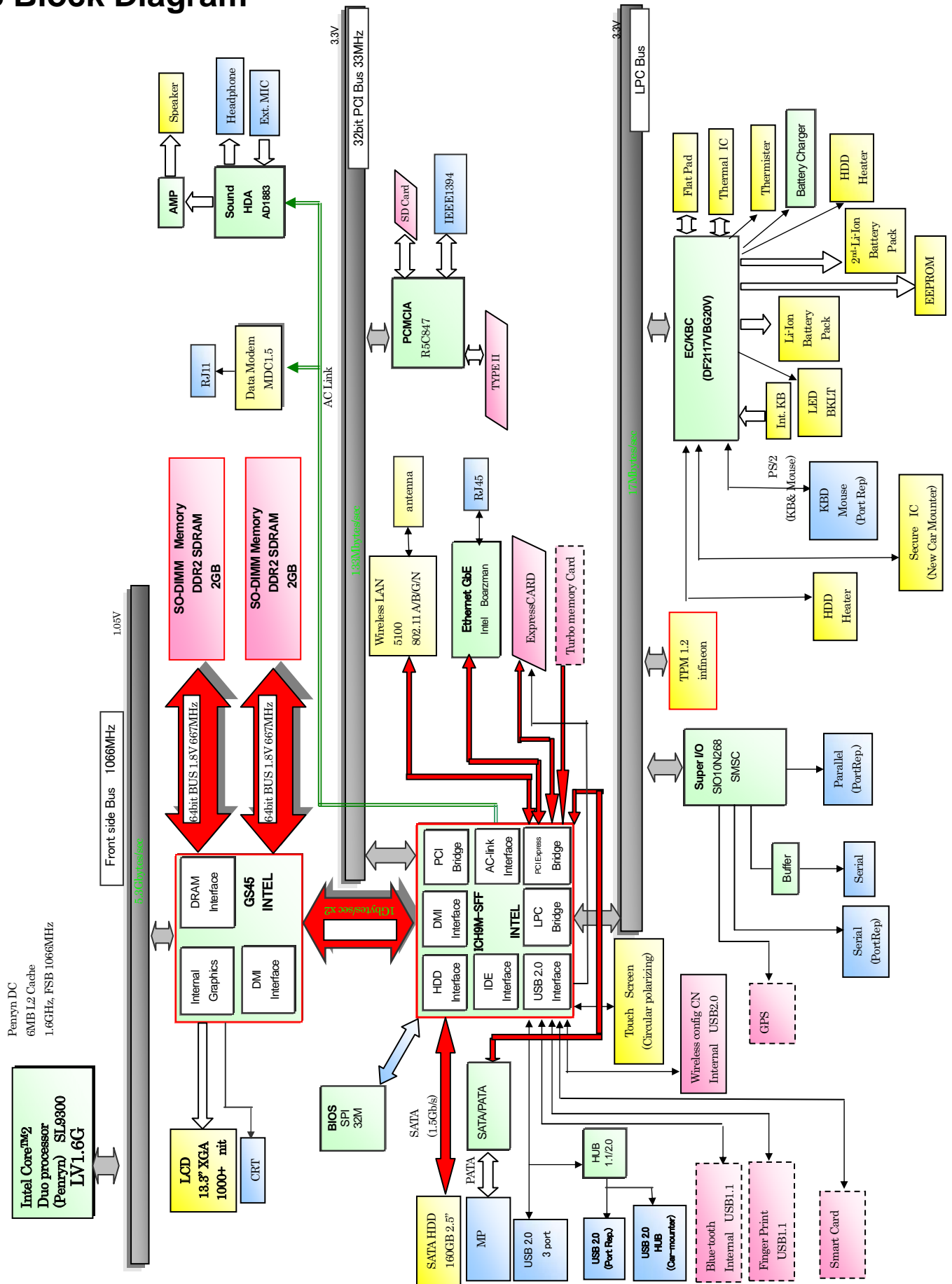

4 Diagnosis Procedure

4.1. Basic Procedures

The basic procedures for diagnosis, disassembly, and test of defective parts of a set to be repaired are summarized below. For details, refer to relevant pages in the Service Manual.

● Flow Chart

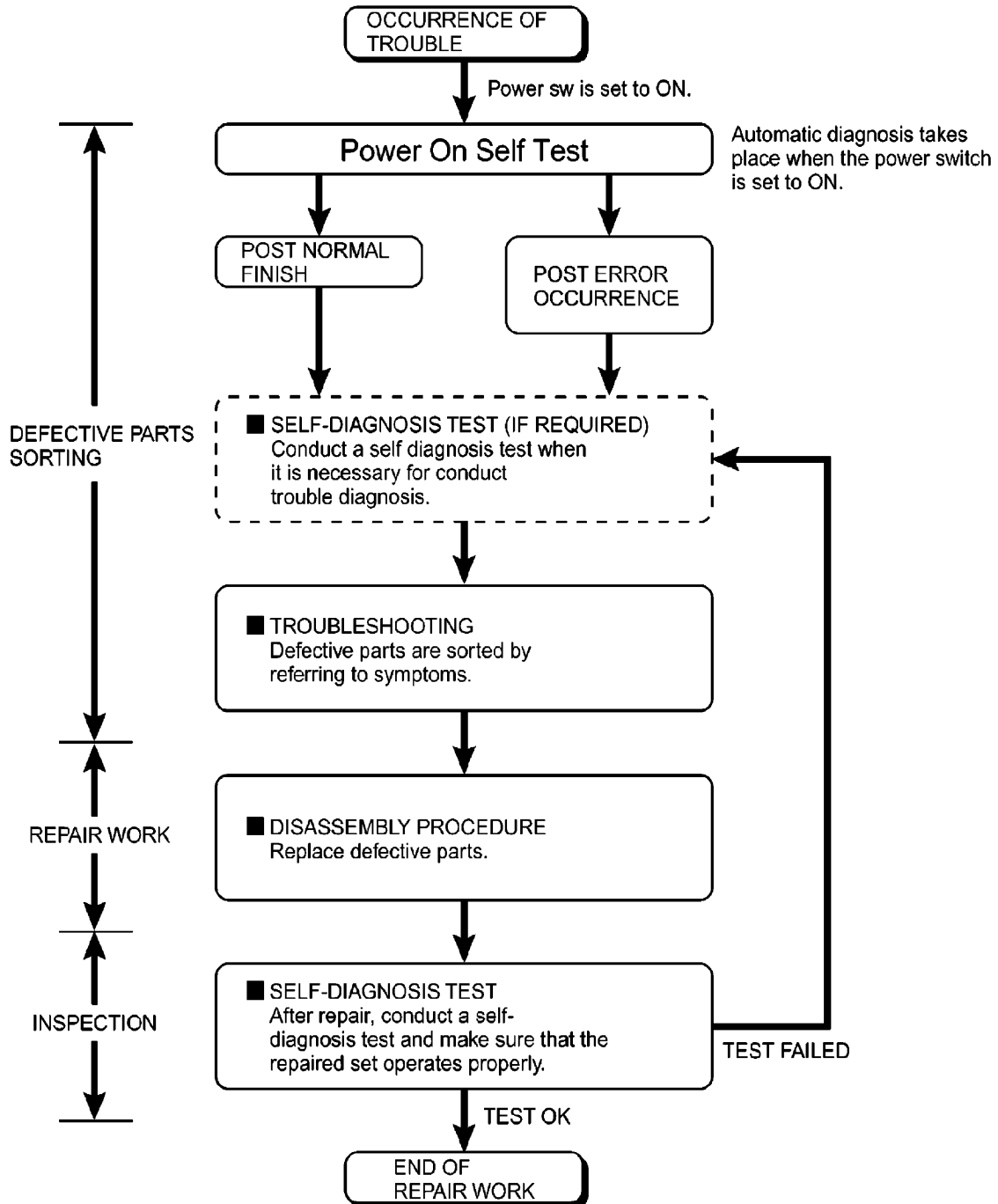

4.2. Troubleshooting

Please take note of the following two points with regard to troubleshooting:

1. Know-how of diagnosis upon occurrence of heavy troubles, e.g. Set cannot be turned ON, Set fails to start, No display on screen, etc.
2. Explanation of each trouble, mainly symptom of trouble in operation.

Flow Chart

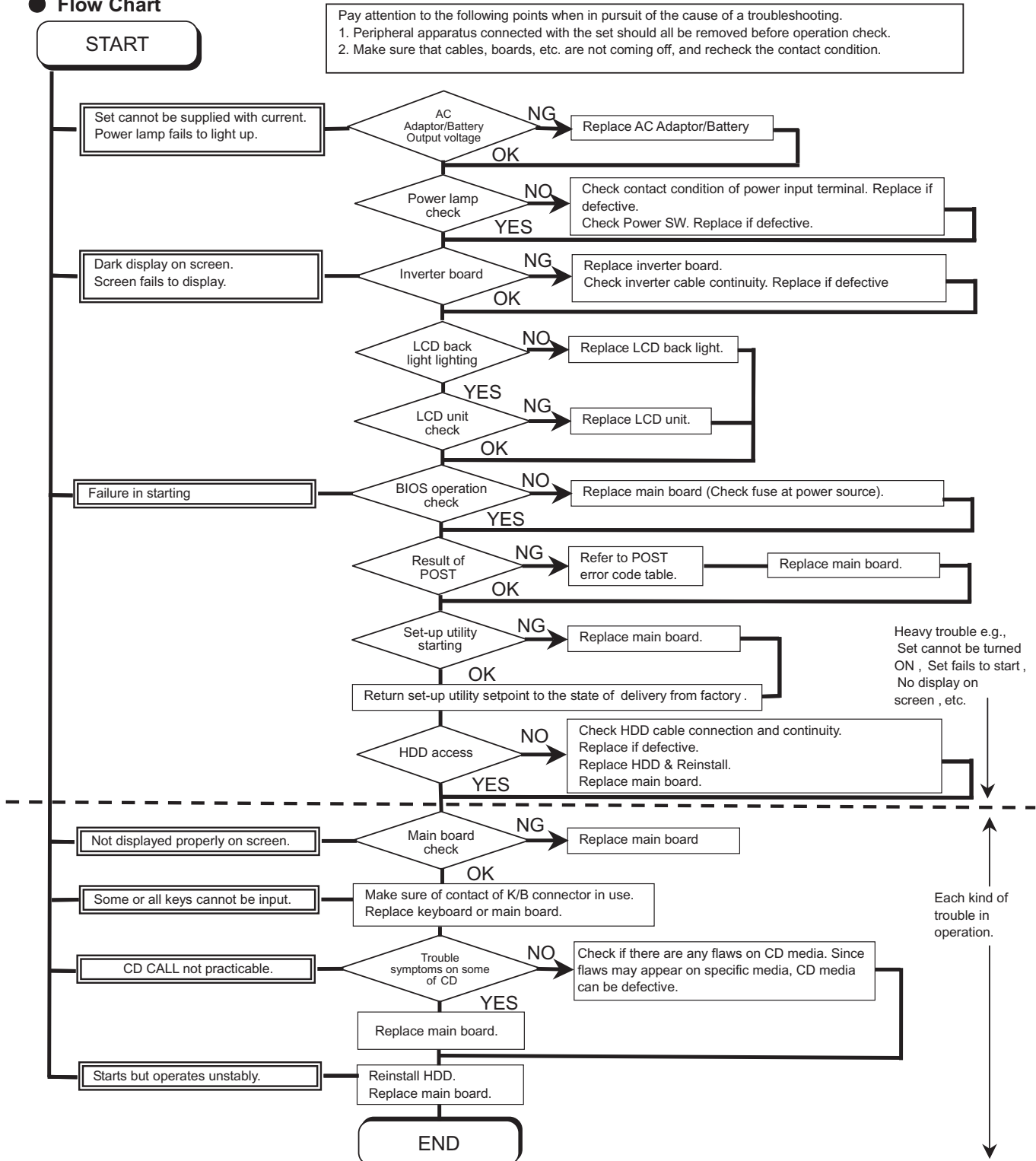

5 Power-On Self Test (Boot Check)

Outline of POST

The set has a boot check function called POST (Power-On Self Test) in it.

The condition of the main body is diagnosed by checking beep sound or error code.

StartTest begins automatically when power switch is set to ON.

Normal finishAfter memory checking, a beep sound is issued once and the set is placed into automatic stop.

Note: If no error occurs, nothing is displayed. (No display of OK, etc.)

Error Diagnosis by Checking Beep Signal Sound

The beep sound is as follows:



(Length of bar shows length of sound.)

■ = long sound (about 0.4 sec.), ■ = short sound (about 0.2 sec.), Length between sounds is about 0.1 sec.

Table of errors classified by beep sounds

Diagnosis	Beep signal sound	Error message
Main board	1(long sound)-2	BIOS ROM error
	1-2-2-3	BIOS ROM error
	1-3-1-1	RAM error
	1-3-1-3	Keyboard controller error
	1-3-4-1	RAM error
	1-3-4-3	RAM error
	1-4-1-1	RAM error
	2-1-2-3	BIOS ROM error
	2-2-3-1	Occurrence of unexpected offering

(Note) A beep sound is also issued in case of other I/O trouble.

6 List of Error Codes <Only when the port replicator is connected>

The following is a list of the messages that BIOS can display. Most of them occur during POST. Some of them display information about a hardware device, e.g., the amount of memory installed. Others may indicate a problem with a device, such as the way it has been configured. Following the list are explanations of the messages and remedies for reported problems. If your system displays one of except the messages marked below with an asterisk (*), write down the message and contact Panasonic Technical Support. If your system fails after you make changes in the Setup menus, reset the computer, enter Setup and install Setup defaults or correct the error.

0200 Failure Fixed Disk

Fixed disk in not working or not configured properly. Check to see if fixed disk is attached properly. Run Setup. Find out if the fixed-disk type is correctly identified.

0210 Stuck key

Stuck key on keyboard.

0211 Keyboard error

Keyboard not working.

0212 Keyboard Controller Failed

Keyboard controller failed test. May require replacing keyboard controller.

0213 Keyboard locked - Unlock key switch

Unlock the system to proceed.

0230 System RAM Failed at offset : *nnnn*

System RAM failed at offset *nnnn* of in the 64k block at which the error was detected.

0231 Shadow RAM Failed at offset : *nnnn*

Shadow RAM failed at offset *nnnn* of the 64k block at which the error was detected.

0232 Extended RAM Failed at offset : *nnnn*

Extended memory not working or not configured properly at offset *nnnn*.

0250 System battery is dead - Replace and run SETUP

The CMOS clock battery indicator shows the battery is dead. Replace the battery and run Setup to reconfigure the system.

***0251 System CMOS checksum bad - Default configuration used**

System CMOS has been corrupted or modified incorrectly, perhaps by an application program that changes data stored in CMOS. The BIOS installed Default SETUP Values. If you do not want these values, enter Setup and enter your own values. If the error persists, check the system battery or contact Panasonic Technical Support.

0260 System timer error

The timer test failed. Requires repair of system board.

0270 Real time clock error

Real-time clock fails BIOS test. May require board repair.

***0280 Previous boot incomplete - Default configuration used**

Previous POST did not complete successfully. POST loads default values and offers to run Setup. If the failure was caused by incorrect values and they are not corrected, the next boot will likely fail. On systems with control of **wait states**, improper Setup settings can also terminate POST and cause this error on the next boot. Run Setup and verify that the wait-state configuration is correct. This error is cleared the next time the system is booted.

0281 Memory Size found by POST differed from EISA CMOS

Memory size found by POST differed from EISA CMOS.

02D0 System cache error - Cache disabled

Contact Panasonic Technical Support.

02F0: CPU ID:

CPU socket number for Multi-Processor error.

02F4: EISA CMOS not writable

ServerBIOS2 test error: Cannot write to EISA CMOS.

02F5: DMA Test Failed

ServerBIOS2 test error: Cannot write to extended DMA (Direct Memory Access) registers.

02F6: Software NMI Failed

ServerBIOS2 test error: Cannot generate software NMI (Non-Maskable Interrupt).

02F7: Fail - Safe Timer NMI Failed

ServerBIOS2 test error: Fail-Safe Timer takes too long.

device address Conflict

Address conflict for specified *device*.

Allocation Error for: *device*

Run ISA or EISA Configuration Utility to resolve resource conflict for the specified *device*.

Failing Bits : *nnnn*

The hex number *nnnn* is a map of the bits at the RAM address which failed the memory test. Each 1 (one) in the map indicates a failed bit. See error 230,231 or 232 for offset address of the failure in System, Extended or Shadow memory.

Invalid System Configuration Data

Problem with NVRAM (CMOS) data.

I/O device IRQ conflict

I/O device IRQ conflict error.

Operating System not found

Operating system cannot be located on either drive A: or drive C:. Enter Setup and see if fixed disk and drive A: are properly identified.

Parity Check 1 *nnnn*

Parity error found in the system bus. BIOS attempts to locate the address and display it on the screen. If it cannot locate the address, it displays ????. Parity is a method for checking errors in binary data. A parity error indicates that some data has been corrupted.

Parity Check 2 *nnnn*

Parity error found in the I/O bus. BIOS attempts to locate the address and display it on the screen. If it cannot locate the address, it displays ????.

Press <F1> to resume, <F2> to Setup

Displayed after any recoverable error message. Press <F1> to start the boot process or <F2> to enter a Setup and change the settings. Write down and follow the information shown on the screen.

7 Self Diagnosis Test

As for the self-diagnosis test(PC-Diagnostic utility) to use this model, a standard test and the enhancing test by the module of the main body building in are possible.

Notes To skip BIOS password

Use <Ctrl>+<F10> key to skip BIOS password or authentication of fingerprint.

This key is only for entering DIAG mode. Not available to boot the computer.

If customer set "HDD Lock", the DIAG program cannot perform HDD test.

*This key is for service purpose only. Do not disclose this information to unrelated others.

1. Beginning of self-diagnosis test

1-1. Setting of content of setup

1. The power supply of the computer is turned on.
2. " F2 " is pushed on the screen of "Panasonic" while " press <F2 to enter Setup> " is displayed.
3. The setup utility starts and then takes notes of the content of the BIOS setup of present set.
4. " F9 " is pushed, " Yes" is selected on the screen of " Is the default value loaded? ", and " Enter" is pushed.
5. " F10 " is pushed.
6. " Yes" is selected on the screen of the setup confirmation, and " Enter" is pushed.
7. The computer starts automatically.

Attention

- If the device which can be set is set to "Invalidity" by "Advanced" or "Security" menu, becomes an error by "PC-Diagnostic utility".
(It is judged that the device which can be set to "Invalidity" by "Main" menu such as "Flat pad" is normal if the controller operates normally though sets to "Invalidity" by the setup.)
- In the model with built-in DVD of the USB connection, even if DVD is normal, becomes an error if legacy USB is set to "Invalidity"

1-2. When you execute an automatic test

1. "Ctrl" + "F7" is pushed while the "Panasonic" start screen is displayed after the computer is started.
2. The test of all devices begins automatically by "PC-Diagnostic utility" 's starting.

Attention

- It is a test which the customer who bought PC can execute. (As for HDD, the enhancing test is also possible.)
- A flat pad does not work for a while after starting "PC-Diagnostic utility".
- The movement of a flat pad might become abnormal If after RAM begins from the CPU/System test, a flat pad will be operated in about 30 seconds. In that case, restarts pushing "Alt" + "Ctrl" + "Del" key. Or, please start "PC-Diagnostic utility" again after doing the power supply switch in the slide, and turning off the power supply.

1-3. When you execute the enhancing test

1. Please let me discontinue diagnosing clicking  to end an automatic test.
2. Please click on the character of "D" "PC-Diagnostic utility" on the screen while pushing both of right "Shift" and left "Shift" keys.



3. All devices which can select the enhancing test make the setting of the enhancing test possible.
4. The district device is made "FULL" display (enhancing test).
5. The test begins clicking .

*Please refer to item 4 for the error result of each test and the division of the breakdown part.

2. Operation of PC-Diagnostic Utility

- Only the device which can be inspected on the entire screen is displayed.
- The item does not appear when the device of wireless LAN etc. is not physically connected.
- The movement of the item must use an arrow key or a flat pad.



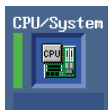

- As for the device under the diagnosis, blue and yellow are alternately displayed at the left of the icon.
- The diagnosis result of the device greens at the left of the icon when it is normal, and becomes red when abnormal.



- When the test of all devices ends, the test result is displayed under the right of the screen.



- Please click  while diagnosing when being stop on the way by the time the test of all devices ends.
- Please click  when you restart "PC-Diagnostic utility".
- *Each device is tested from the beginning, and it is not possible to restart on the way.
- When the test of all devices ends, the test result is displayed under the right of the screen.

2-1. Selection of tested device

- To test only a specific device, "Test" and "Do not test" of each device can be selected.
- The device which can select the enhancing test changes in order of "The standard is tested" and "Do not test" whenever the device icon is clicked.



Start the standard test



Do not test

Please begin testing clicking  if the selection of the tested device ends.

2-2. "PC-Diagnostic utility" End method

When of "Close" on the right of the screen is clicked, the computer reactivates automatically. Or, the power supply switch is done in the slide and the power supply is turned off.

2-3. The content of the setup is returned to the setting of the user

1. Turned on the computer.
2. "F2" is pushed on the screen while "Press<F2>to enter Setup" is displayed of "Panasonic".
3. Push "F10", and on the screen of "Is the change in the setting preserved and do end?"and then "Yes" is selected, and "Enter" is pushed.
4. The computer reactivates automatically.
5. The end option is chosen by the start menu, and the power supply of the computer is turned off.

Standard at test time

All devices other than RAM and HDD ----- about 1 minute
RAM standard test ----- 1 - 2 minutes
HDD standard test ----- 2 - 3 minutes
HDD enhancing test (60GB) ----- about 40 minutes

Ex.The standard when the standard <all device> is tested becomes $1+2+3=6$ minutes.

There is greatly a difference from RAM test when the memory is increased according to the performance of the memory occasionally.

Moreover, when the main body of PC under the test is a high temperature, it occasionally takes time.

There is greatly a difference from HDD according to the performance of the drive occasionally.

3. Test Item and Division of trouble

Test item	Standard	Enhancing	Content of standard test	Content of enhancing test	Place with possibility of breakdown
CPU / SYSTEM	○	—	CPU is shifted to protected mode, and "Violation of the paging", "Operation of the violation of a privileged instruction", and DMA, INT, TIMER, and the RTC operation are confirmed.	—	CPU / Main board
RAM	○	—	All memory space is tested in a special memory access pattern based on "R.S.T . technology".	—	Memory / Mainboard
HDD	○	○	The record area frequently accessed with Microsoft Windows XP to test in about two minutes regardless of points of HDD is emphatically tested.	All record area is tested.	HDD / Mainboard / Cable / Connector
MODEM	○	—	It is confirmed not to find abnormality in the AC97 modem controller.	—	MODEM/ Mainboard
Wireless LAN	○	—	It is confirmed not to find abnormality in the Wireless LAN modem controller.	—	Wireless LAN board / Connector / Mainboard
Sound *5	○	—			
USB	○	○ ^{*1}	It is confirmed not to find abnormality in the USB controller.	It is confirmed not to find abnormality in the wiring between the USB controller and the connector by confirming the connection of the USB equipment connected with the USB connector.	Mainboard / Connector
LAN	○	○ ^{*2}	It is confirmed not to find abnormality in the LAN controller.	It is confirmed not to find abnormality in the wiring between the controller and the connector by connecting to HUB with LAN cable.	Mainboard / Connector
PC Card	○	—	It is confirmed not to find abnormality in the CardBus controller.	—	Mainboard
SD	○	—	It is confirmed not to find abnormality in the SD controller.	—	Mainboard
Keyboard	○	○ ^{*3}	It is confirmed not to find abnormality in keyboard controller's keyboard interface.	The key is actually input, and the operation is displayed on the screen.	Mainboard / Keyboard
Touch Pad	○	○ ^{*4}	Whether keyboard controller's mouse interface operates normally is confirmed.	The operation is actually displayed on the screen by operating the touch pad.	Mainboard / Touch Pad
DVD-ROM	○	○ ^{*6}	The drive is normally reset, and it is accessible is confirmed.	It is confirmed to be able to read media normally.	Mainboard / DVD Drive / DVD Cable / DVD Connector

Test Item	Standard	Enhanced	Content of Standard Test	Content of Extend Test	The place with possibility of breakdown
Touch Screen	○	○	It is confirmed not to find abnormality in the USB connection of Touch Screen. This test cannot find abnormality of Touch Screen.	Perform Touch Screen functionality practically. Operator has to judge PASS/FAIL with test result.	Main board/ Touch Screen
Bluetooth	○		It is confirmed not to find abnormality in the connection of Main board and Bluetooth module.	—	Bluetooth cable
Wireless WAN	○	—	It is confirmed not to find abnormality in the connection of Main board and Wireless WAN module.	—	WWAN cable
Floppy	○	—	It is confirmed not to find abnormality in the legacy FD drive. This test cannot find abnormality of mechanical breakdown. (e.g., Head, Motor)	—	FD Drive/ Main board (Super I/O)/ FDD cable FDD connector
Video	○	—	It is confirmed not to find abnormality in access to VRAM with VESA. The PC which uses main memory as VRAM may fail with main memory failure.	—	Main board (Chipset, Graphic Controller)/ Memory
GPS	○	—	It is confirmed not to find abnormality in the connection of Main board and GPS	—	GPS cable
IEEE1394	○	—	It is confirmed not to find abnormality in the IEEE1394 controller.	—	Main board (IEEE1394 Controller)
Express Card	—	○	—	It is confirmed not to find abnormality in the wiring between Chipset and Express Card.	Main board (Chipset)/ Express Card Connector
Smart Card	○	—	It is confirmed not to find abnormality in the Smart Card controller.	—	Main board (Smart Card Controller)
Serial Port	○	○ *7	It is confirmed not to find abnormality of Super I/O UART function. This test cannot find lack of wiring between Super I/O and Serial Connector.	It is confirmed not to find abnormality in the wiring between Super I/O and Serial Connector. This test cannot find failure of cable characteristic and device problems.	Main board (Super I/O)/ Serial Connector
Parallel Port	○	○ *8	It is confirmed not to find abnormality of Super I/O parallel function. This test cannot find lack of wiring between Super I/O and Parallel Connector.	It is confirmed not to find abnormality in the wiring between Super I/O and Parallel Connector. This test cannot find failure of cable characteristic and device problems.	Main board (Super I/O)/ Parallel Connector

*1 Please connect the USB device with the port (USB connector) which wants to test before the tests.

*2 Please connect LAN port with LAN HUB with LAN cable before the tests.

*3 The operator actually inputs the key, and the operator judges PASS/FAIL of the test.

*4 The operator actually operates the mouse, and the operator judges PASS/FAIL of the test.

*5 It is not abnormal though the sound is emitted from the speaker while testing.

※ When the test result is PASS, trouble is thought by not hearing of the sound under the test from the speaker and the headphone by the wiring of the audio output system.

*6 Please set DVD/CD media in the drive before the tests.

*7 Please set a Special Loop Back Connector Tool at serial connector for Enhanced Test. (This Connector Tool is same as the one used before.)

*8 Please set a Special Loop Back Connector Tool at parallel connector for Enhanced Test. (This Connector Tools is same as the one used before.)

8 Wiring Connection Diagram

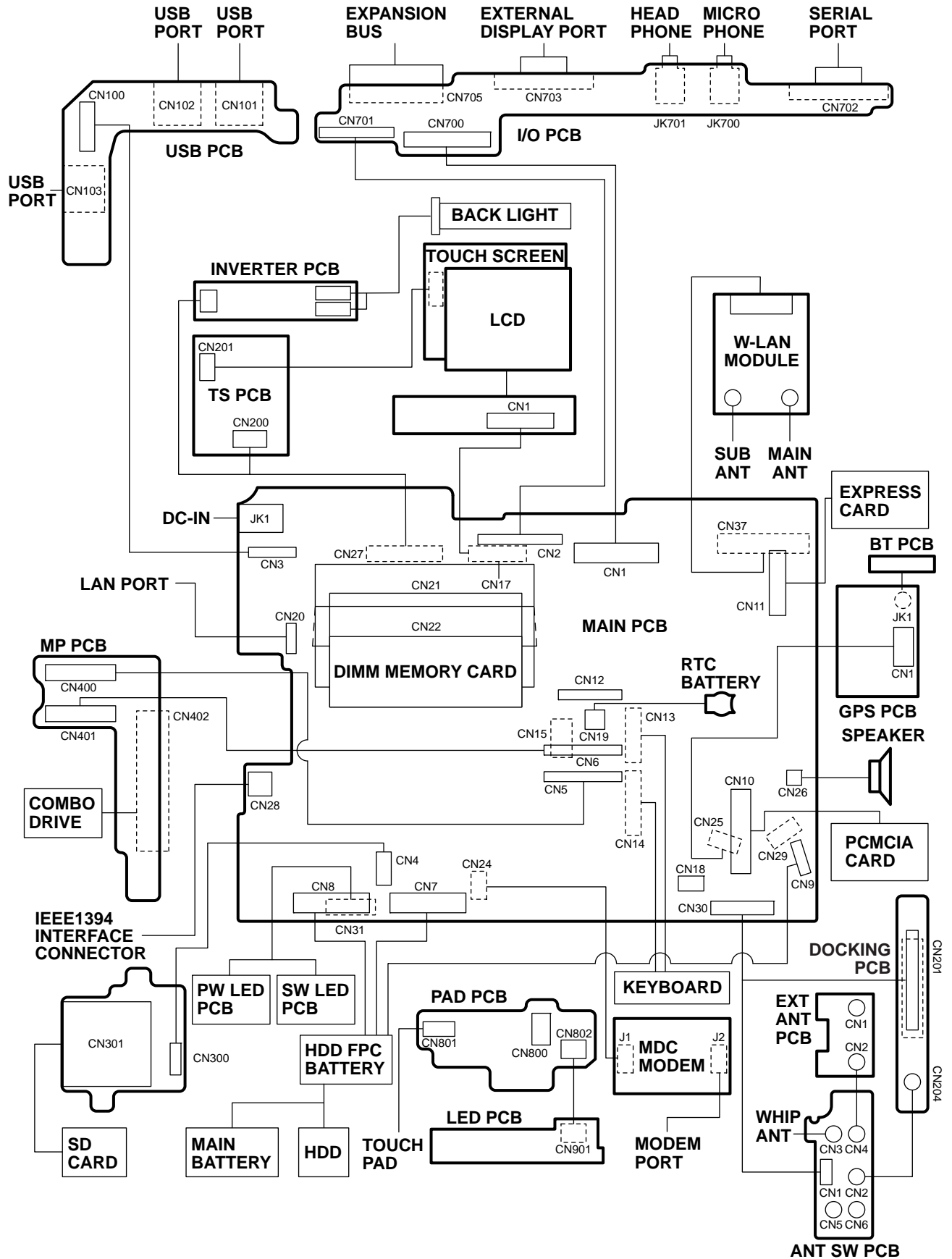

9 Disassembly/Reassembly

Note:

Power off the computer. Do not shut down to the Suspend or hibernation mode.

Do not add peripherals while the computer is in the Suspend or hibernation mode; abnormal operation may result.

9.1. Disassembly Instructions

9.1.1. Preparation

Before disassembling, be sure to make the following preparations.

- Shut down Windows and turn off the power.
- Disconnect the AC adaptor.
- Remove the optional DIMM memory card and PCMCIA card if they are connected.
- Remove other devices if they are connected.

Attention:

- Please execute writing BIOS ID when you exchange the Main Board.
- Parts (Sheet and rubber) etc. related various the Conductive Cloth and Heat Spreader cannot be recycled. Use new parts.

9.1.2. Removing the Battery Pack and HDD Pack

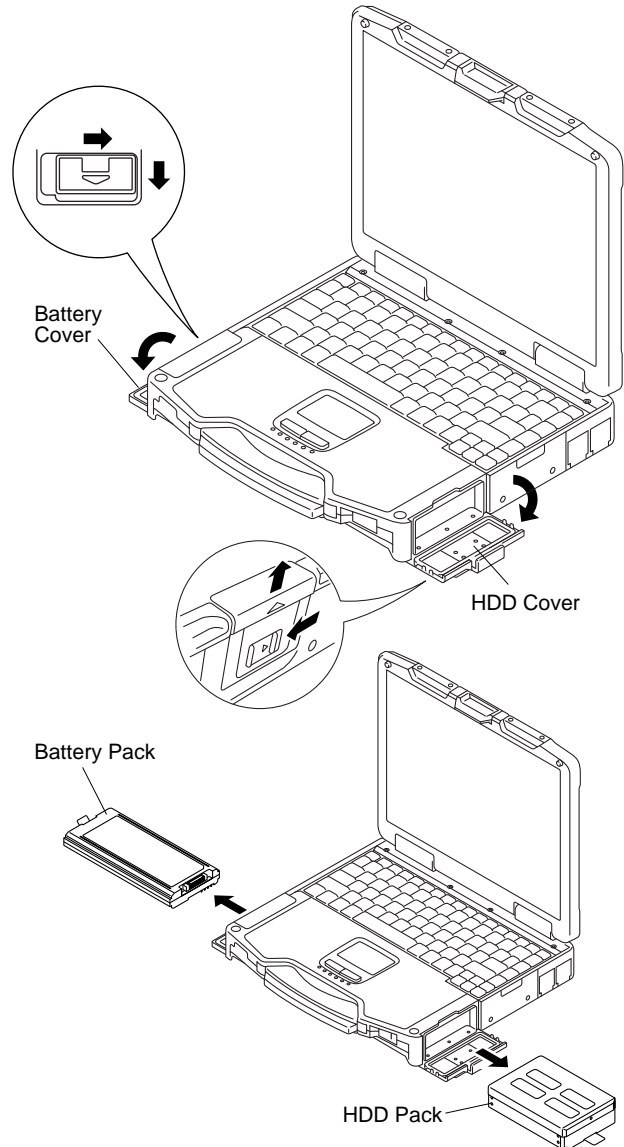

1. Open the Battery Cover.
2. Remove the Battery Pack.
3. Open the HDD Cover.
4. Remove the HDD Pack.

9.1.3. Removing the HDD

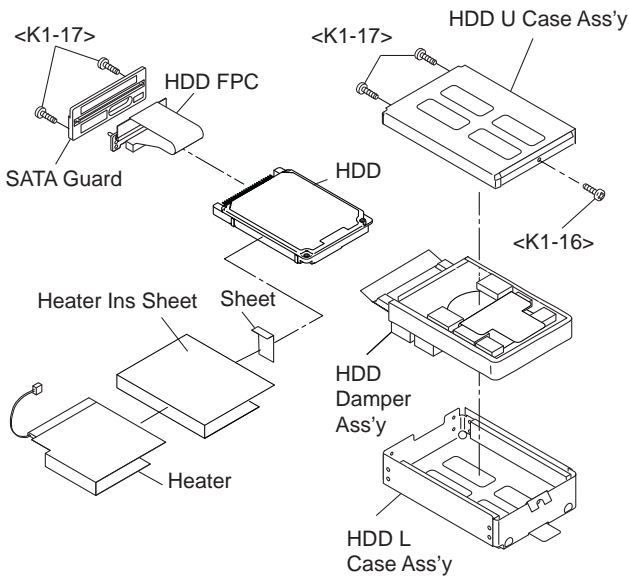

1. Remove the Screw. <K1-16>
2. Remove the 4 Screws. <K1-17>
And remove the SATA Guard.
3. Release the 2 Tabs, and remove the HDD U Case Ass'y and the HDD L Case Ass'y.
4. Remove the HDD Damper Ass'y.
5. Remove the Sheet.
6. Remove the Heater and the Heater Ins Sheet.
7. Remove the HDD FPC.

Screws <K1-16>: DFHE5025XA
Screws <K1-17>: DRQT2+E8FKL

9.1.4. Removing the KB Cover, Hinge Cover L, Hinge Cover R and Keyboard

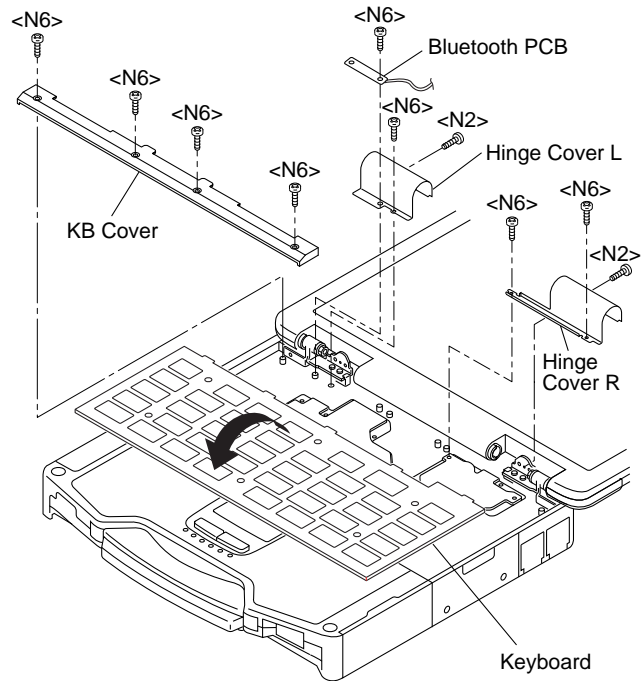

1. Remove the 4 Screws <N6>, and remove the KB Cover.
2. Remove the 2 Screws <N2> and the 3 Screws <N6>, and remove the Hinge Cover L,R.
3. Remove the Keyboard.

Screws <N2>: DRHM5054XA
Screws <N6>: DRQT26+E4FKL

9.1.5. Removing the KB Cable Cover and LCD Cable Cover

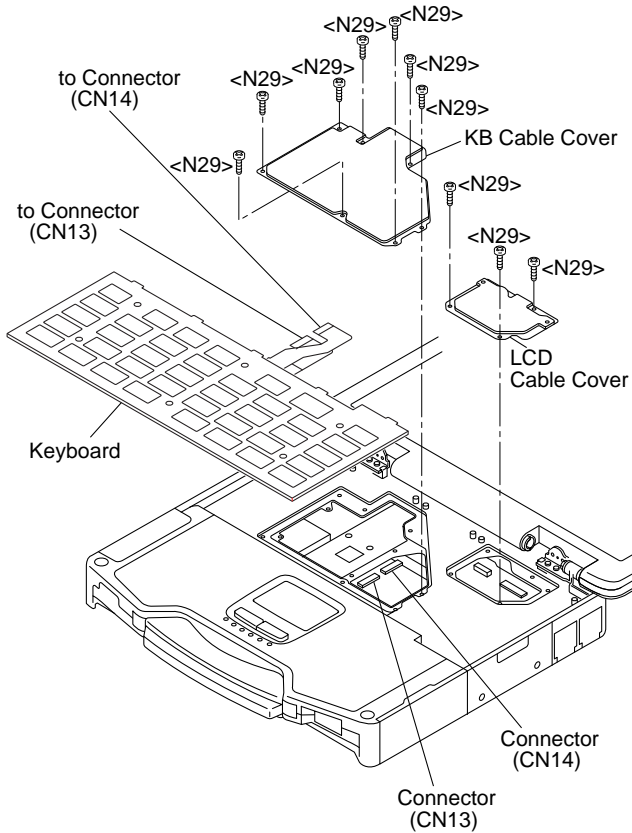

1. Remove the 3 Screws <N29>.
2. Remove the LCD Cable Cover.
3. Remove the 7 Screws <N29>.
4. Remove the KB Cable Cover.
5. Disconnect the 2 Cable from the 2 Connectors (CN13, CN14).
6. Remove the Keyboard.

Screws <N29>: DRQT26+E3FNL

9.1.6. Removing the GPS PCB, Bluetooth PCB and W-LAN Module

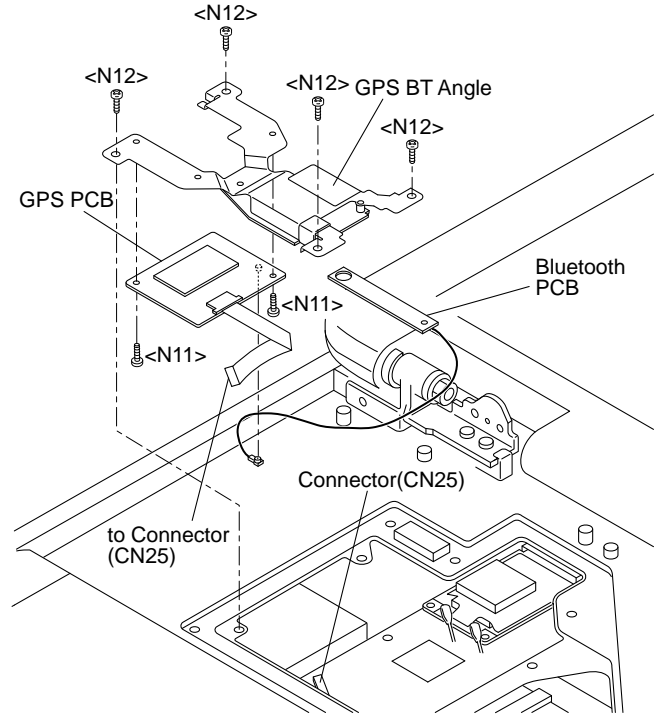

1. Disconnect the Cable from the Connector. (CN25)
2. Remove the 4 Screws. <N12>
3. Remove the 2 Screws. <N11>
4. Remove the Bluetooth PCB, GPS BT Angle and GPS PCB.

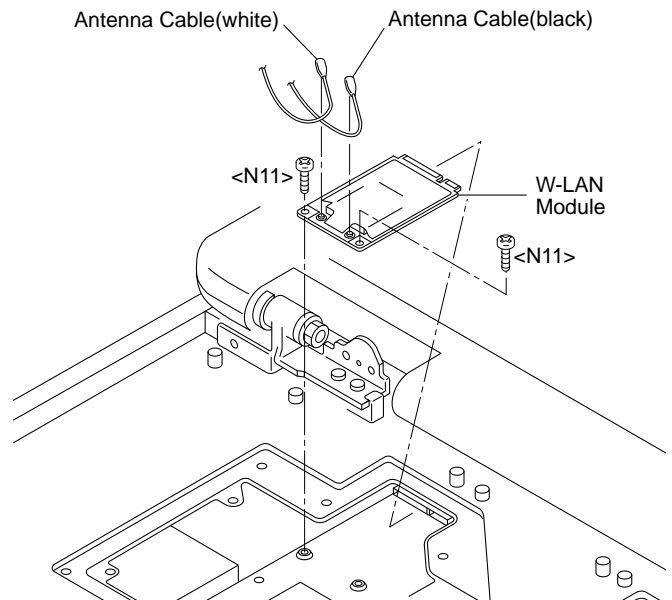

5. Disconnect the 2 Antenna Cables.(White/Black)
6. Remove the 2 Screws. <N11>
7. Remove the W-LAN Module

Screws <N11>: DFHE5025XA
Screws <N12>: DXQT2+F3FNL

9.1.7. Removing the DIMM Cover and Bottom Cover

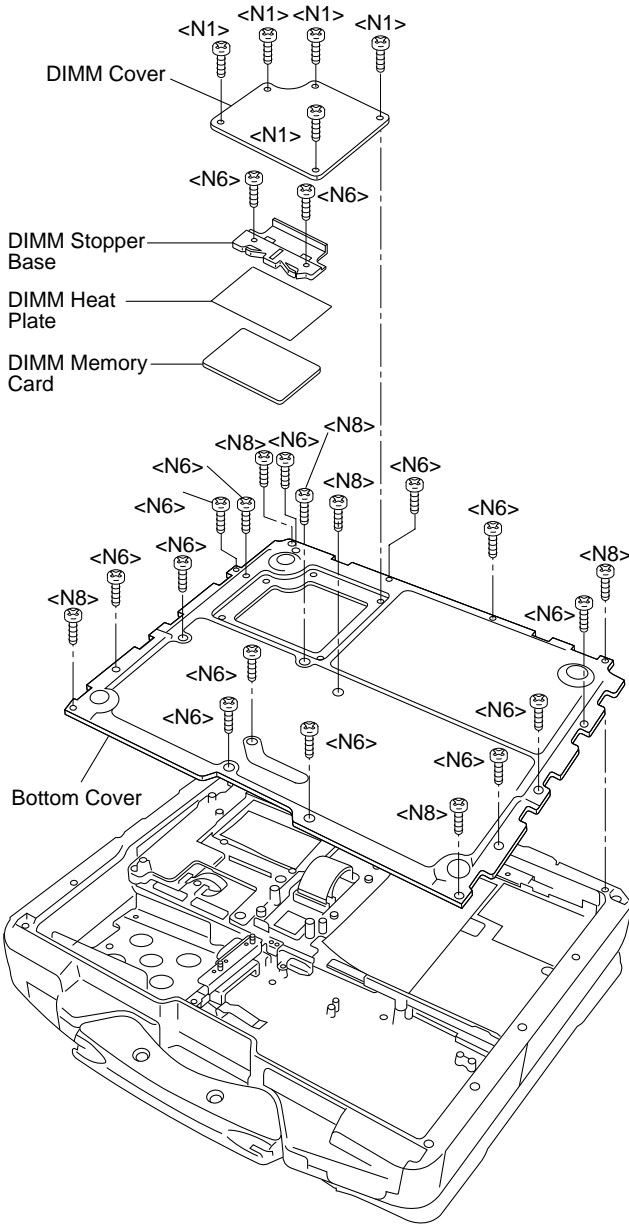

1. Remove the 5 Screws. <N1>
2. Remove the DIMM Cover.
3. Remove the 2 Screws. <N6>
4. Remove the DIMM Stopper Base.
5. Remove the DIMM Heat Plate.
6. Remove the DIMM memory card.
7. Remove the 6 Screws. <N8>
8. Remove the 13 Screws. <N6>
9. Remove the Bottom Cover.

Screws <N1>: DRHM0002ZA
 Screws <N6>: DRQT26+E4FKL
 Screws <N8>: DRSB3+8FKL

9.1.8. Removing the USB PCB and Antenna PCB

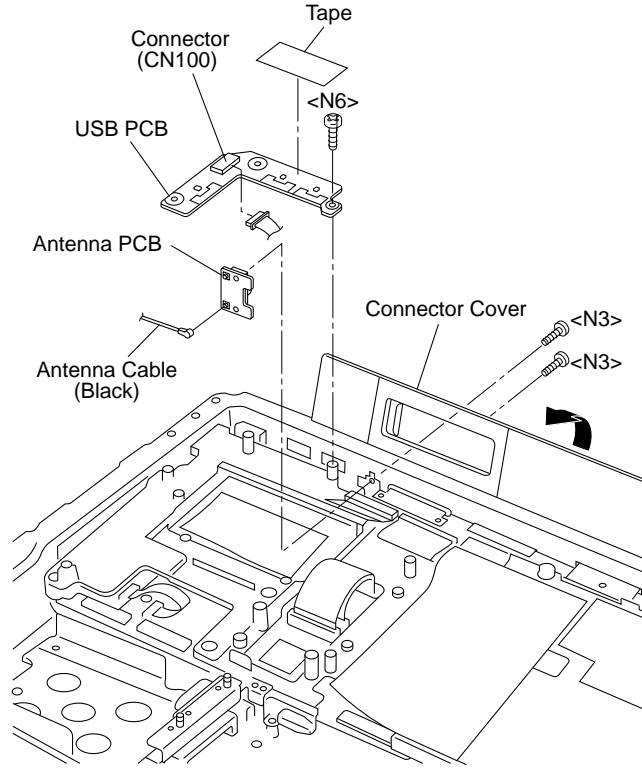

1. Remove the Screw. <N6>
2. Disconnect the Cable from the Connector. (CN100)
3. Remove the Tape.
4. Remove the USB PCB.
5. Open the Connector Cover.
6. Remove the 2 Screws. <N3>
7. Remove the Black Cable and remove the Antenna PCB.

Screws <N3>: DRQT2+G6FKL
 Screws <N6>: DRQT26+E4FKL

9.1.9. Removing the FPC HDD BAT

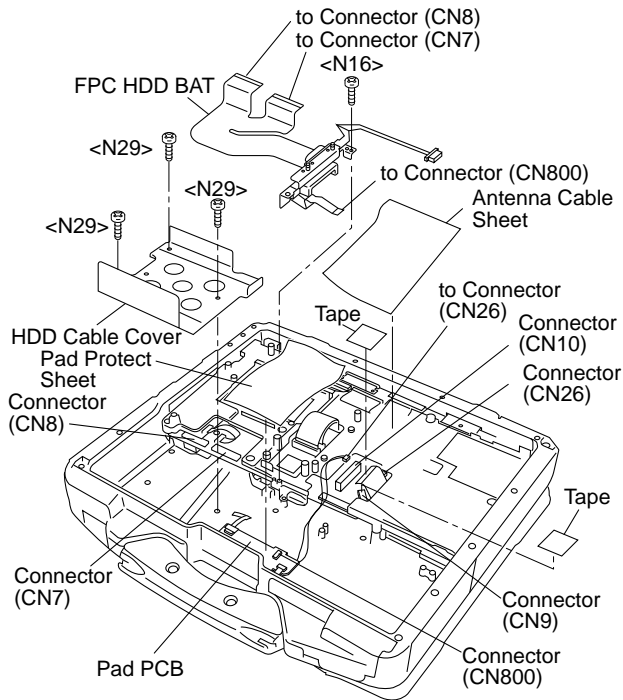

1. Remove the 3 Screws. <N29>
2. Remove the HDD Cable Cover.
3. Remove the Antenna Cable Sheet.
4. Remove the 2 Tapes.
5. Disconnect the 2 Cables from the 2 Connectors. (CN10,CN26)
6. Remove the Tape.
7. Disconnect the Cable from the Connector. (CN9)
8. Remove the Pad Protect Sheet.
9. Disconnect the Cable from the Connector. (CN800)
10. Disconnect the 2 Cables from the 2 Connectors. (CN7,CN8)
11. Remove the Screw. <N16>
12. Remove the FPC HDD BATT.

Screws <N16>: DRQT26+E5FKL

Screws <N29>: DRQT26+E3FNL

9.1.10. Removing the PAD PCB

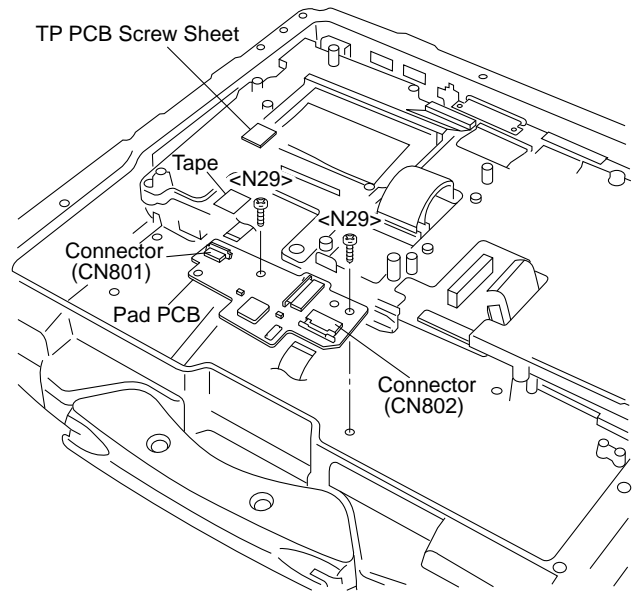

1. Remove the Tape and disconnect the Cable from the Connector. (CN801)
2. Disconnect the Cable from the Connector. (CN802)
3. Remove the TP PCB Screw Sheet.
4. Remove the 2 Screws. <N29>
5. Remove the PAD PCB.

Screws <N29>: DRQT26+E3FNL

9.1.11. Removing the Main PCB

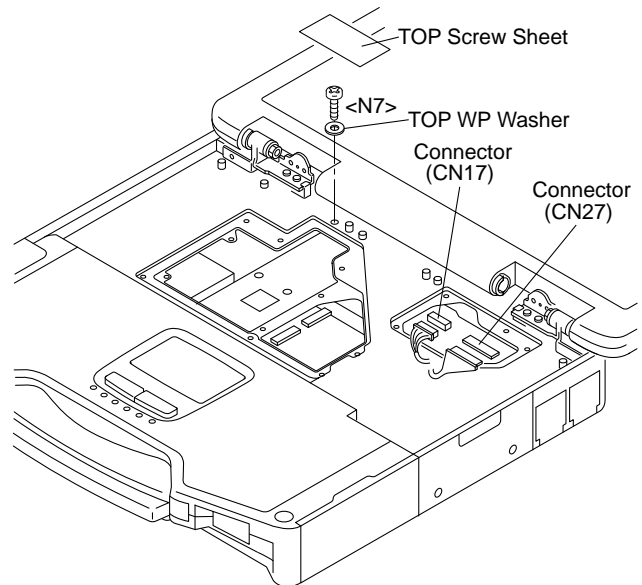

1. Remove the TOP Screw Sheet.
2. Remove the Screw. <N7>
3. Remove the TOP WP Washer.
4. Disconnect the 2 Cables from the 2 Connectors. (CN17,CN27)

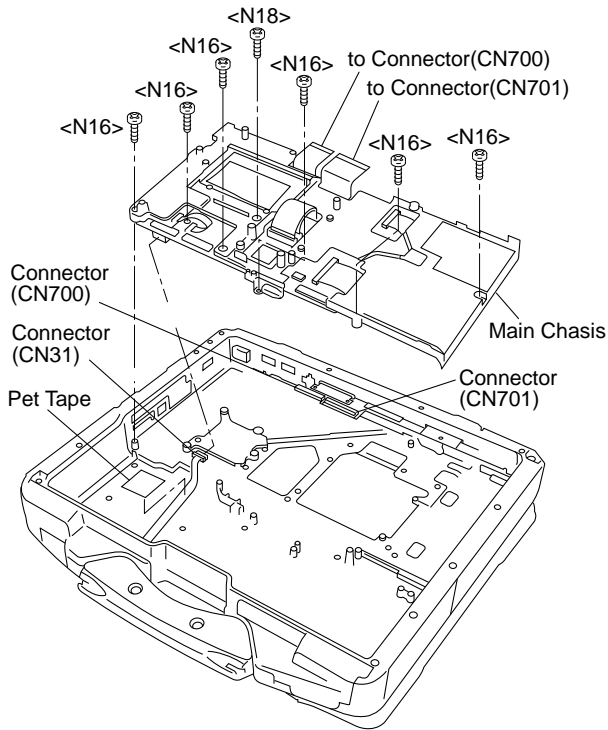

5. Remove the 6 Screws. <N16>
6. Remove the Screw. <N18>
7. Disconnect the 2 Cables from the 2 Connectors. (CN700,CN701)
8. Remove the Pet Tape and disconnect the Cable from the Connector. (CN31)
9. Remove the Main chasis.

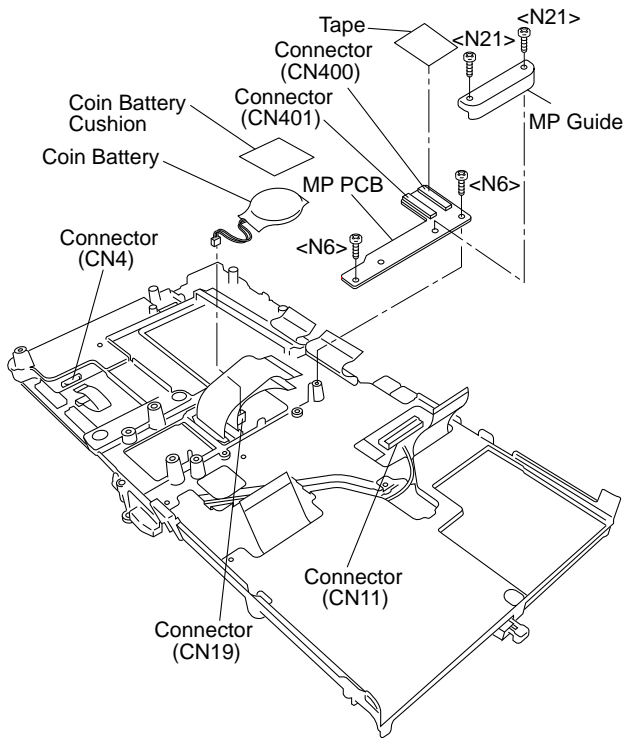

10. Remove the Tape.
11. Disconnect the 2 Cables from the 2 Connectors. (CN400,CN401)

12. Remove the 2 Screws. <N6>
13. Remove the 2 Screws. <N21>
14. Remove the MP Guide.
15. Remove the MP PCB.
16. Remove the Coin Battery Cushion.
17. Disconnect the Cable from the Connector. (CN19)
18. Remove the Coin Battery.
19. Remove the Tape.
20. Disconnect the 2 Cables from the 2 Connectors. (CN4,CN11)

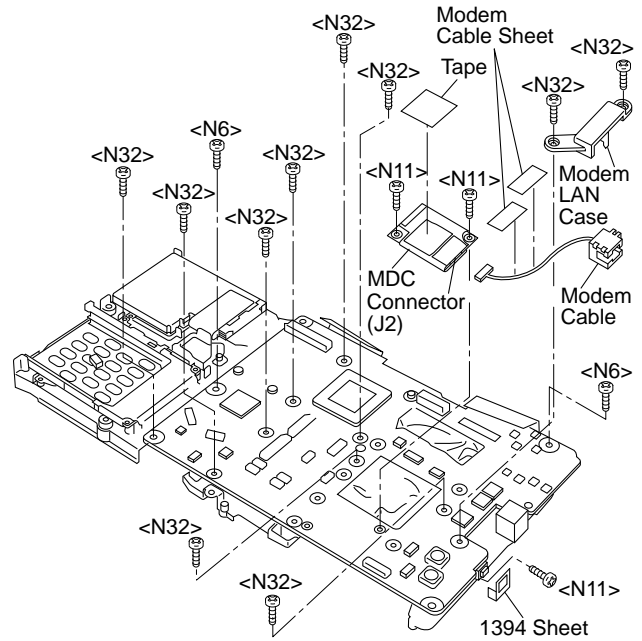

21. Remove the 2 Modem Cable Sheets.
22. Remove the 2 Screws. <N32>
23. Remove the Modem LAN Case.
24. Remove the 1394 Sheet.
25. Remove the 2 Screws. <N11>
26. Remove the Tape.
27. Disconnect the Cable from the Connector (J2) and remove the MDC.
28. Remove the Modem Cable.
29. Remove the 8 Screws. <N32>
30. Remove the 2 Screws. <N6>
31. Remove the Screw. <N11>
32. Remove the Main PCB.

Screws <N6>: DRQT26+E4FKL
 Screws <N7>: DRSB26+10HKL
 Screws <N11>: DFHE5025XA
 Screws <N16>: DRQT26+E5FKL
 Screws <N18>: DRSB26+8FKL
 Screws <N21>: DXQT2+E12FNL

9.1.12. Removing the SD PCB, Express Card and PCMCIA Card

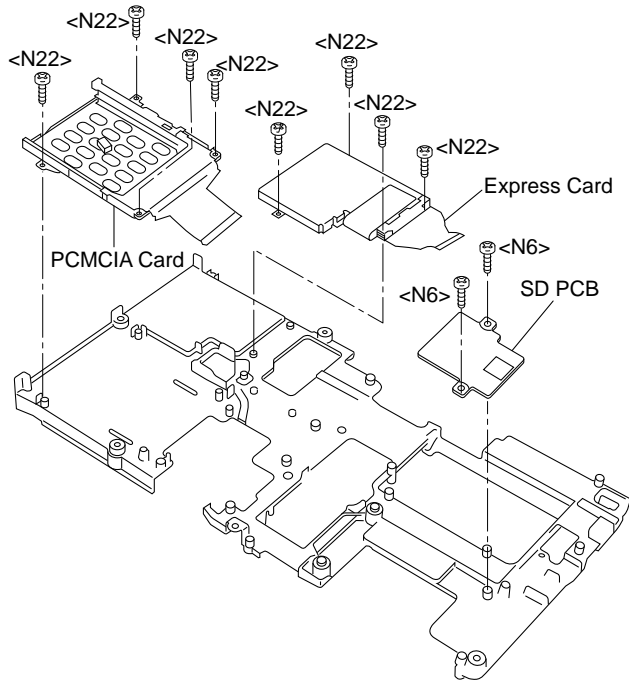

1. Remove the 2 Screws. <N6>
2. Remove the SD PCB.
3. Remove the 4 Screws. <N22>
4. Remove the Express Card.
5. Remove the 4 Screws. <N22>
6. Remove the PCMCIA Card.

Screws <N6>: DRQT26+E4FKL
 Screws <N22>: DXQT2+G4FNL

9.1.13. Removing the I/O PCB

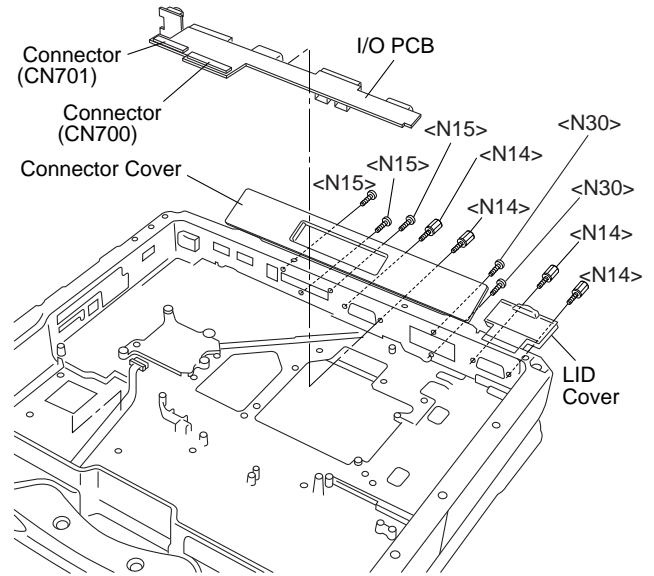

1. Open the Connector Cover and Lid Cover.
1. Remove the 3 Screws <N14> and the 2 Screws <N30>.
1. Remove the 4 Screws. <N15>
1. Remove the I/O PCB.

Screws <N14>: DFHE5058ZB
 Screws <N15>: DRHM5104ZA
 Screws <N30>: DXHM0057ZA

9.1.14. Removing the Palm Top Cover Sheet, Palm Top Cover, Touch Pad Adhesion Seat, Touch Pad, Touch Pad SW Knob, LED PCB and SW LED PCB

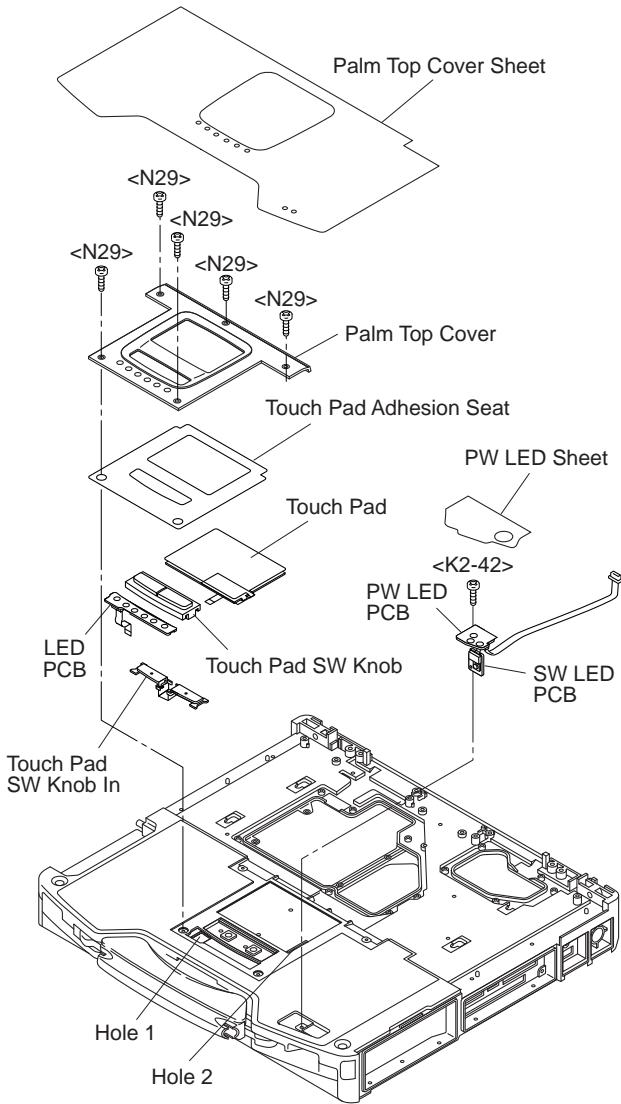

1. Remove the Palm Top Cover sheet.
2. Remove the 5 Screws <N29>, and remove the Palm Top Cover.
3. Remove the Touch Pad Adhesion seat.
4. Remove the Touch Pad.
5. Remove the Touch Pad SW knob and Touch Pad SW Knob in.
6. Remove the LED PCB.
7. Remove the PW LED Sheet.
8. Remove the Screw <K2-42>, and remove the SW LCD PCB.

Screws <N29>: DRQT26+E3FNL
 Screws <K2-42>: DXQT26+D4NLT

9.1.15. Removing the Handle and Power SW

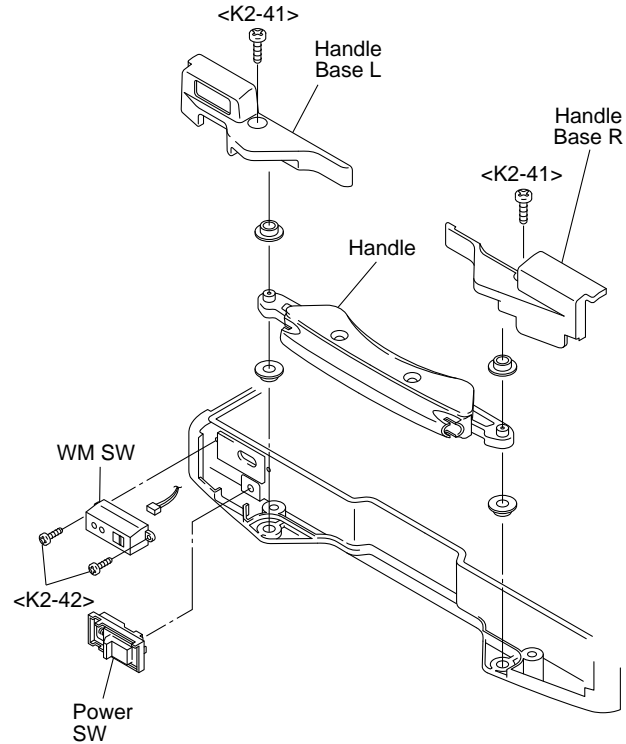

1. Remove the 2 Screws <K2-41>, and remove the Handle Base L and R.
2. Remove the Handle.
3. Remove the 2 Screws. <K2-42>
4. Remove the WM SW and Power SW.

Screws <K2-41>: DRSN4+6FKLT
 Screws <K2-42>: DXQT26+D4NLT

9.1.16. Removing the Display Unit

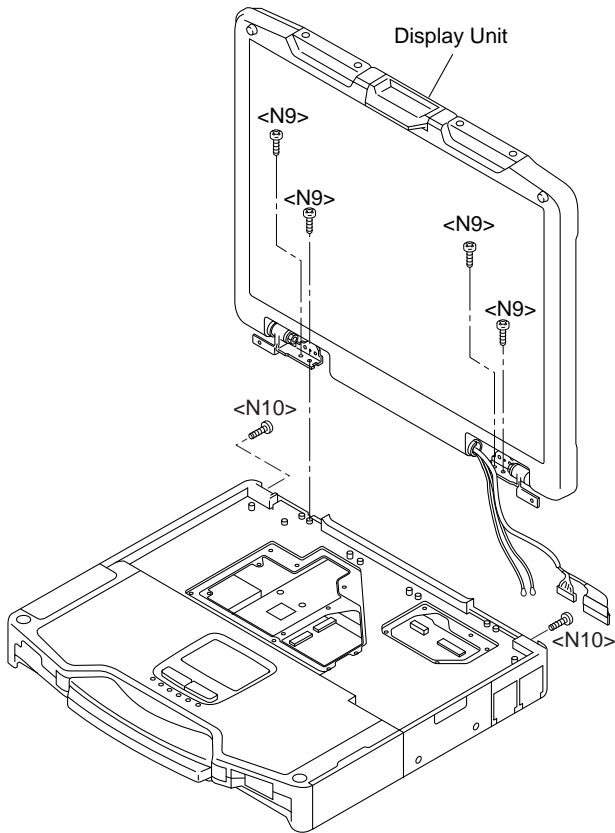

1. Remove the 2 Screws <N10> and the 4 Screws <N9>.
2. Remove the Display Unit.

Screws <N9>: DRYN4+J10FKL
 Screws <N10>: DXSB4+15FNLB

9.1.17. Removing the LCD Rear Cabinet, Hinge L and R and W-RDY ANT Unit

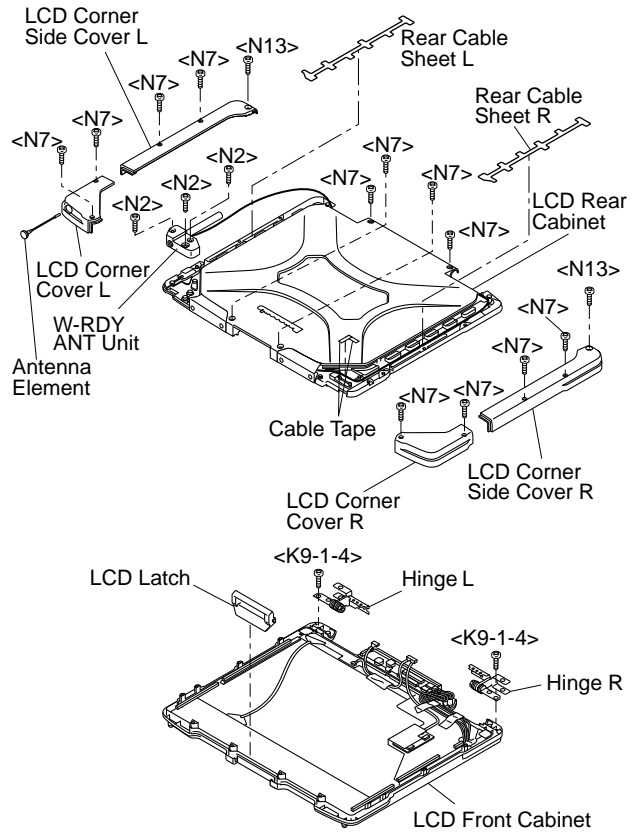

1. Remove the 12 Screws <N7> and 2 Screws. <N13>
2. Remove the LCD Corner Cover L / R.
3. Remove the LCD Coner Side Cover L / R.
4. Remove the Rear Cable Sheet L / R and 2 Cable Tape.
5. Remove the 3 Screws. <N2>
6. Remove the W-RDY ANT Unit.
7. Remove the LCD Rear Cabinet.
8. Remove the LCD Latch.
9. Remove the 2 Screws. <K9-1-4>
10. Remove the Hinge L and R.

Screws <N2>: DRHM5054XA
 Screws <N7>: DRSB26+10HKL
 Screws <N13>: DRSB4+10FKL
 Screws <K9-1-4>: DRYN4+J10KLT

9.1.18. Removing the Inverter PCB, TS PCB and LCD Unit

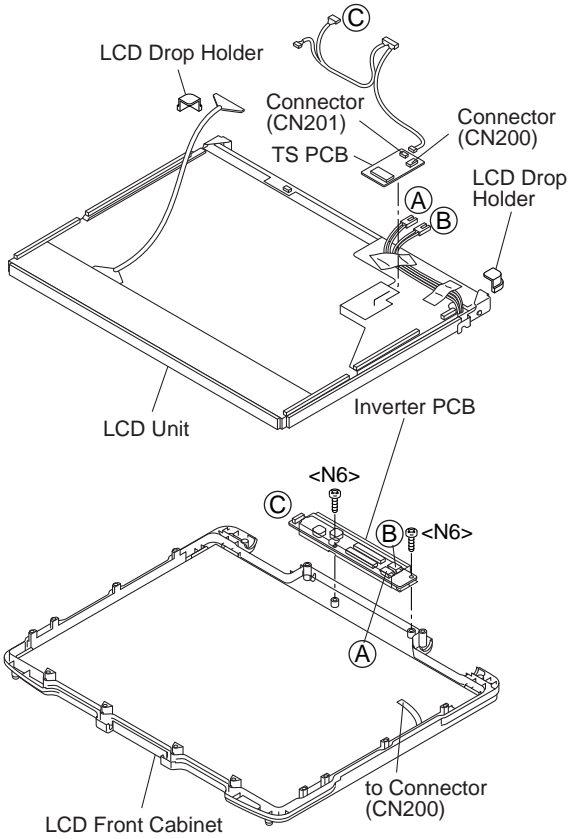

1. Remove the 2 Screws. <N6>
2. Disconnect the 3 Cables from the 3 Connectors.
3. Remove the Inverter.
4. Disconnect the 2 Cables from the 2 Connectors. (CN200, CN201)
5. Remove the TS PCB.
6. Remove the 2 Drop Holders.
7. Remove the LCD Unit.

Screws <N6>: DRQT26+E4FKL

9.1.19. Removing the Antenna PCB L and R

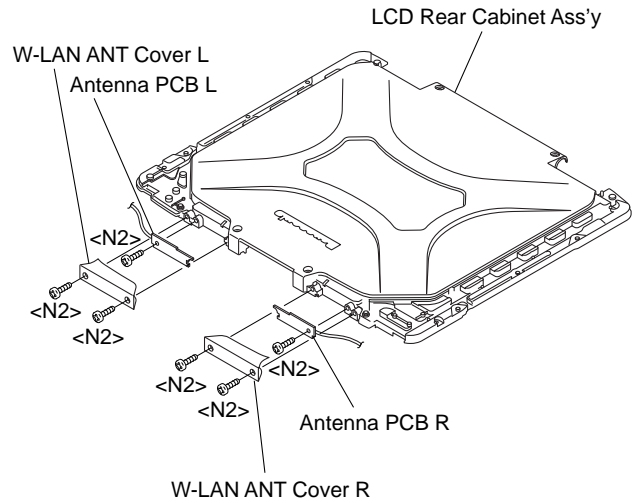

1. Remove the 4 Screws <N2>.
2. Remove the W-LAN ANT Cover L and R.
3. Remove the 2 Screws. <N2>
4. Remove the Antenna PCB L and R.

Screws <N2>: DRHM5054XA

9.2. Reassembly Instructions

9.2.1. Attention when CF-30 series is repaired

- Please execute writing BIOS ID when you exchange the Main Board.
- Parts (Sheet and rubber) etc. related various the Conductive Cloth and Heat Spreader cannot be recycled. Use new parts.

9.2.2. Setting the Antenna PCB L and R

1. Set the Antenna PCB L and R using the 2 Screws <N2>.
2. Fix the W-LAN ANT Cover L and R using the 4 Screws <N2> (No1 to No2).

Note:

Tighten the Screws in the numbered order (No1 to No4).

Screws <N2>: DRHM5054XA

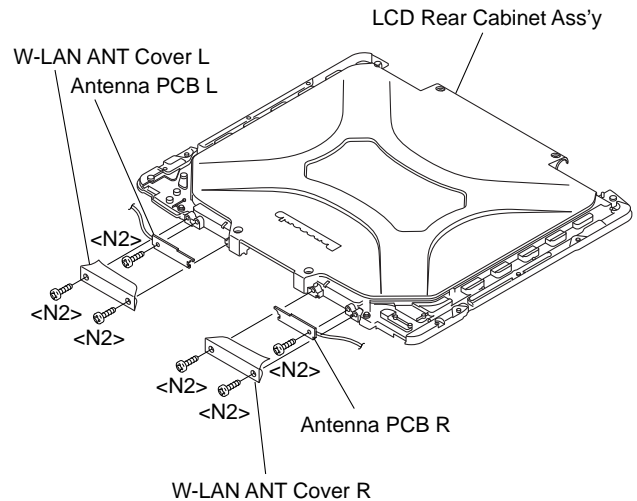

Arranging the Antenna L and R Cables

Torque of tightening screw : 0.45– 0.05N•m (≒ 4.5 – 0.5kgf•cm)

Insert the cable between the pins.

Insert the cable between the pins.

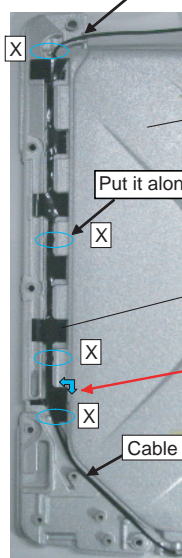

S2 Do not pinch the cable out of the cabinet

Rear Cable Sheet L
Coming off the tape is arrowed

Attach it fitting to the corner

Cable color : Black

Match it to the protrusion side and attach it between the bosses.

Safety Working

CAUTION

S1:Insulation S2:Bitten S3:Sharp Edge
S4:Part No. Check S5:Other

S2 Do not pinch the cable out of the cabinet

Rear Cable Sheet R

Cable color : Gray

Rear Screw Sheet

Match it to the concave side and attach it between the bosses.

Tape **S2** Do not pinch the cable out of the cabinet

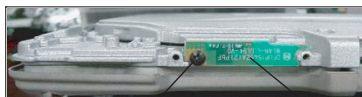

Tighten the screw

Place the antenna main



Place the antenna sub

Tighten the screw

9.2.3. Setting the Inverter PCB, TS PCB and LCD Unit

1. Set the LCD Unit to the LCD Front Cabinet in order.
2. Attach the 2 drop holders.
3. Connect the Cable to the Connector. (CN200,CN201)
4. Connect the 3 Cables to the 3 Connectors.
5. Fix the Inverter PCB using the 2 Screws <N6> (No1 to No2).

Note:

Tighten the Screws in the numbered order (No1 to No2).

Screws <N6>: DRQT26+E4FKL

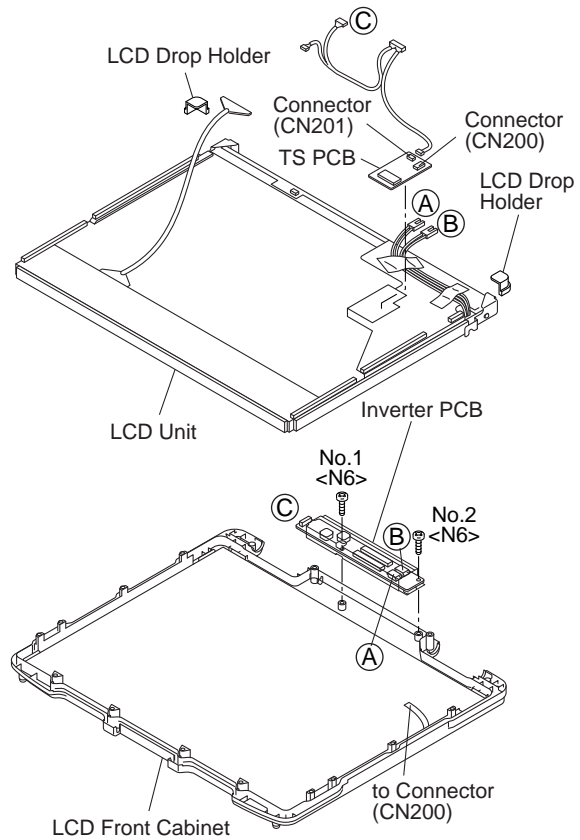

Preparation of Inverter

N0GF1J000009 (Non T/S model)

Check the product number. N0GF1J000009

INV Shield Case

Prepare INV Shield Case and INV Shield Case Outside for Assysite.

INV Shield Case Outside

S4

N0GF2J000003 INV PCB

Check the product number. N0GF2J000003

S4

Board attachment

INV Case Set and attach.

INV Shield Case Set

Wrap 2 INV Shield Tapes around INV Shield Case and attach. Ensure that INV Shield Tape does not run over the edge of INV Shield Case.

<INV Shield Tape's Attachment Guide>
Protrusion by wrinkles, etc. = 0.2 or less
Air Bubble = 1 cm2 or less / 1 bubble size
INV Shield Tape Attach.

Attach it putting the protrusion mark next to the caution label.

<Notes>
1. Apply the load when attaching the attaching parts. 20 to 30N (2 to 3Kgf)/cm2
2. When handling INV PCB, do not bend or add an impact.

CAUTION

S1:Insulation S2:Bitten S3:Sharp Edge
S4:Part No. Check S5:Other

Match the board edge and the case edge. Misalignment: 0.5mm or less

Preparations LCD Cable

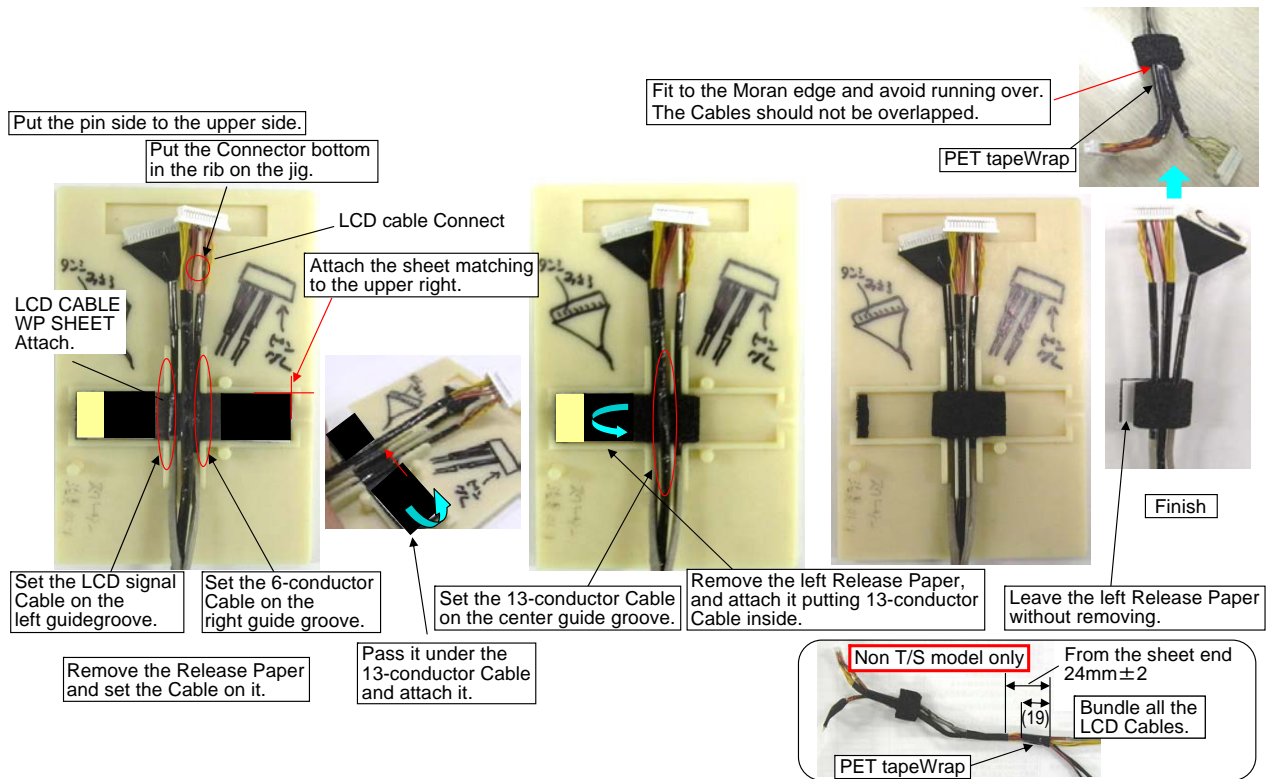

Assembly of LCD Unit

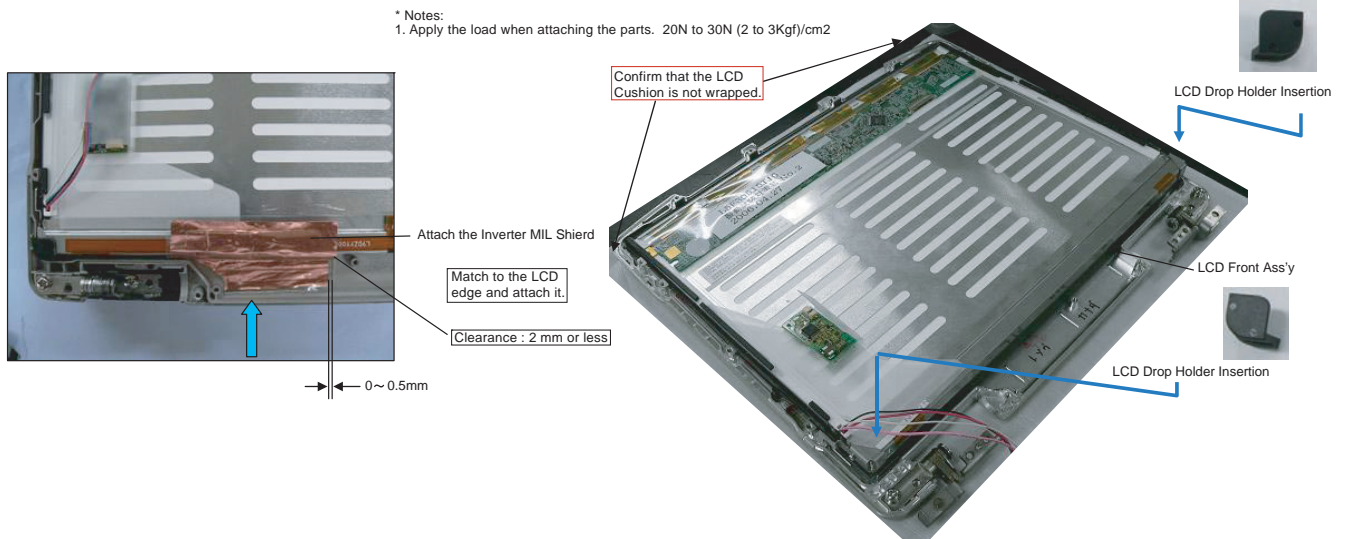

<Notes>

1. Apply the load when attaching the attaching parts. 20 ~ 30N (2 ~ 3Kgf)/cm2

1. Insert the TS Flex into the TS Controller, and attach the tape.
2. Remove the Release Paper A and attach the TS Controller.
(Do not float the sheet and apply the load on the LCD.)
3. Remove the Release Paper B and attach it on the TS Controller.
4. Remove the Release Paper C and attach it on the LCD.

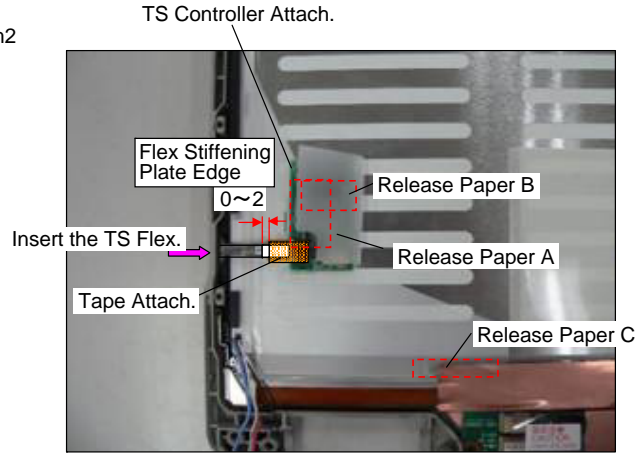

1. Apply the load when attaching the attaching parts. 20 to 30N (2 to 3Kgf)/cm2
2. Reusing the attaching parts is impossible.
3. Torque of Screw ④=0.45±0.05N·m(≒4.50±0.5kgf·cm)

Fix with Screws in order of the rear number of No.
Ex.) Fix in order of ③-1 to ③-2.

CAUTION

S1:Insulation S2:Bitten S3:Sharp Edge
S4:Part No. Check S5:Other

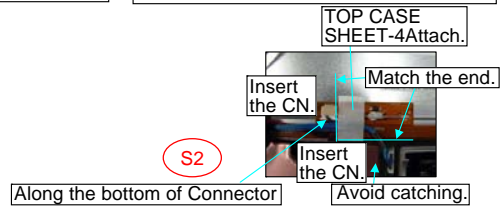
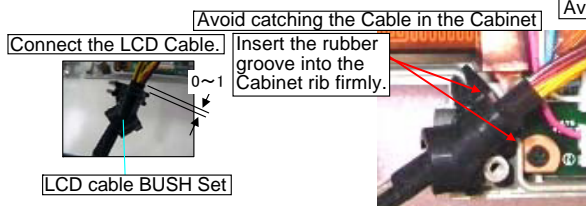
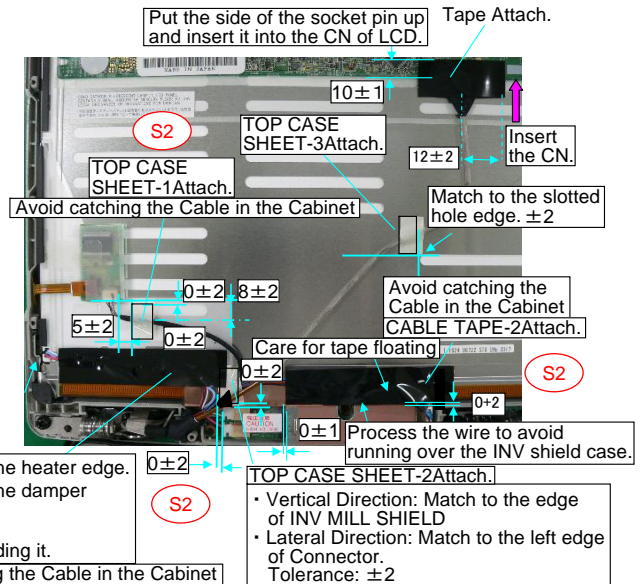
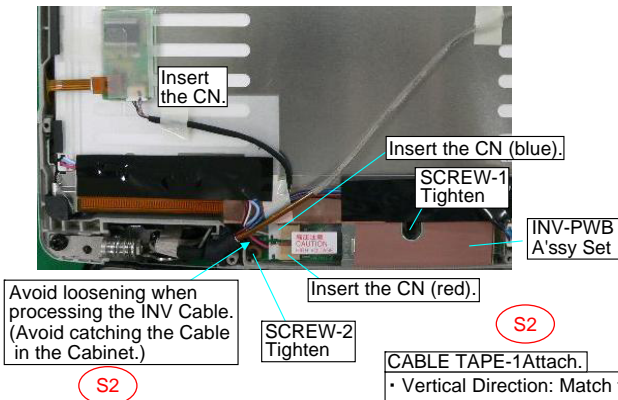

Assembly of LCD Unit (Only the model who doesn't have T/S)

LCD drop holder Insert

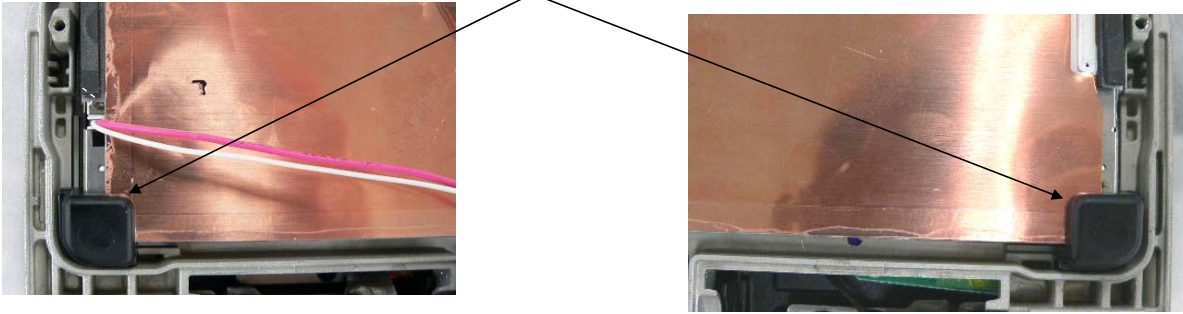

<Notes>

1. Apply the load when attaching the attaching parts. 20 to 30N (2 to 3Kgf)/cm²
2. Reusing the attaching parts is impossible.

Fix with Screws in order of the rear number of No.
Ex.) Fix in order of Screw-1 to Screw-2.

Torque of tightening Screw :0.45 ± 0.02N·m(≒ 4.5 ± 0.2kgf·cm)

Connect the LCD Cable.

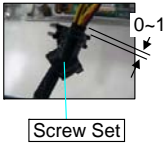

CAUTION S1:Insulation S2:Bitten S3:Sharp Edge
S4:Part No. Check S5:Other

Put the side of the socket pin up and insert it into the CN of LCD.

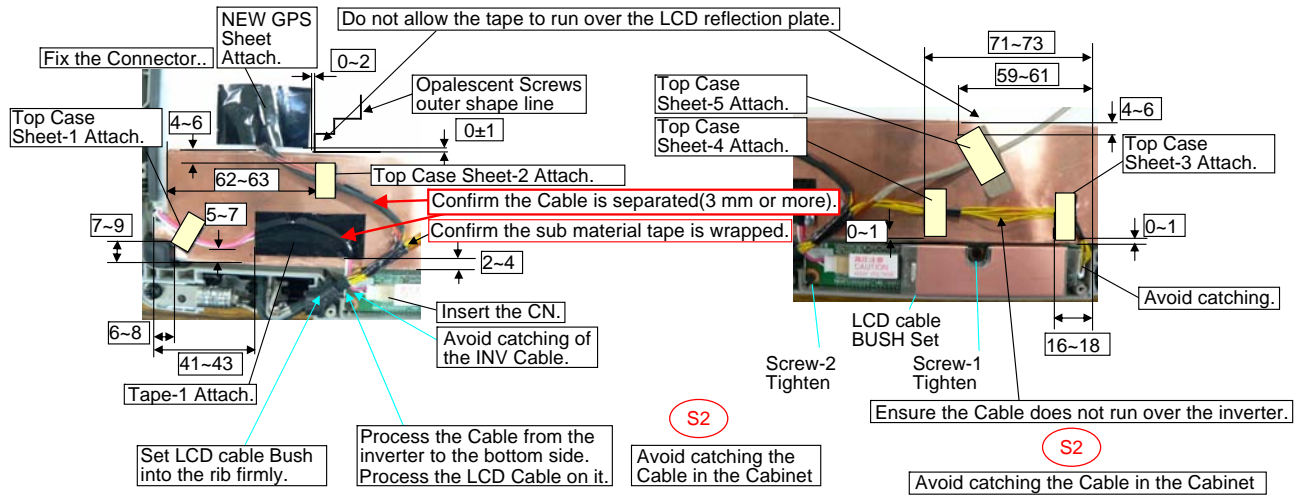
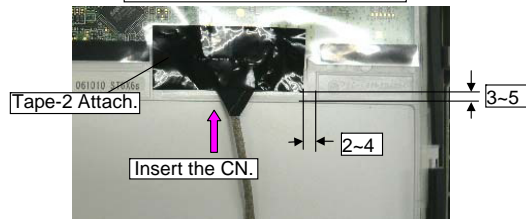

9.2.4. Setting the LCD Rear Cabinet, Hinge L and R and W-RDY ANT Unit

1. Fix the Hinge L and R using the 2 Screws <K9-1-4>.
2. Set the LCD Latch.
3. Fix the W-RDY ANT Unit using the 3 Screws <N2> (No1 to No3).
4. Attach the Rear Cable Sheet L / R and 2 Cable Tape.
5. Attach the LCD Corner Side Cover L / R.
6. Attach the LCD Corner Cover L / R.
7. Fix the LCD Rear Cabinet, LCD Corner Side Cover L / R and LCD Corner Cover L / R using the 12 Screws <N7> (No1 to No 12) and 2 Screws <N13> (No1 to No2).

Note:

- Tighten the Screws in the numbered order (No1 to No3).
- Tighten the Screws in the numbered order (No1 to No12).
- Tighten the Screws in the numbered order (No1 to No2).

- Screws <N2>: DRHM5054XA
- Screws <N7>: DRSB26+10HKL
- Screws <N13>: DRSB4+10FKL
- Screws <K9-1-4>: DRYN4+J10KLT

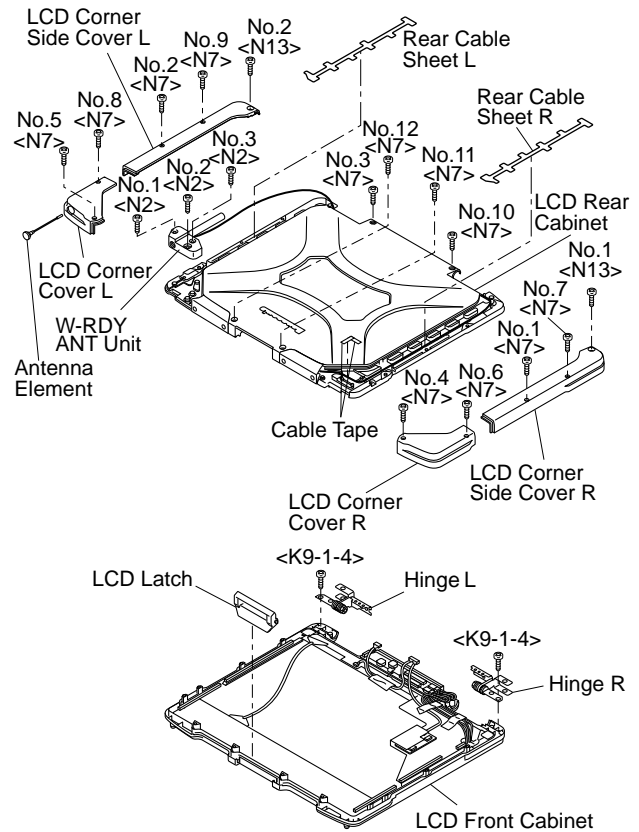

Assembly WHIP ANT ASS'Y

Torque of Screw ②、③、=0.45±0.05N·m(≒4.5±0.5kgf·cm)

Process the WHIP ANT Cable to the upper part.

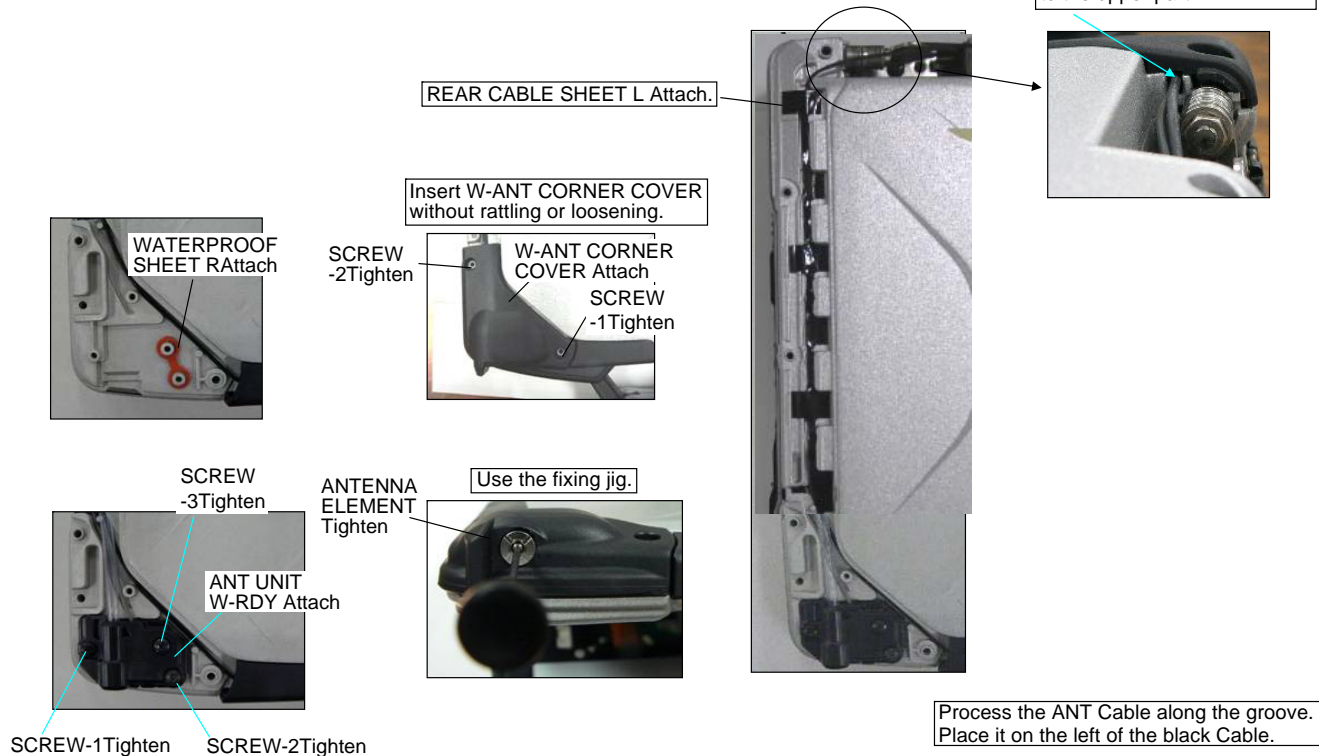

9.2.5. Setting the Display Unit

1. Fix the Display Unit using the 4 Screws <N9> (No1 to No4).
2. Fix the Display Unit using the 2 Screws <N10> (No1 to No2).

Note:

Tighten the Screws in the numbered order (No1 to No4).
Tighten the Screws in the numbered order (No1 to No2).

Screws <N9>: DRYN4+J10FKL
Screws <N10>: DXSB4+15FNLB

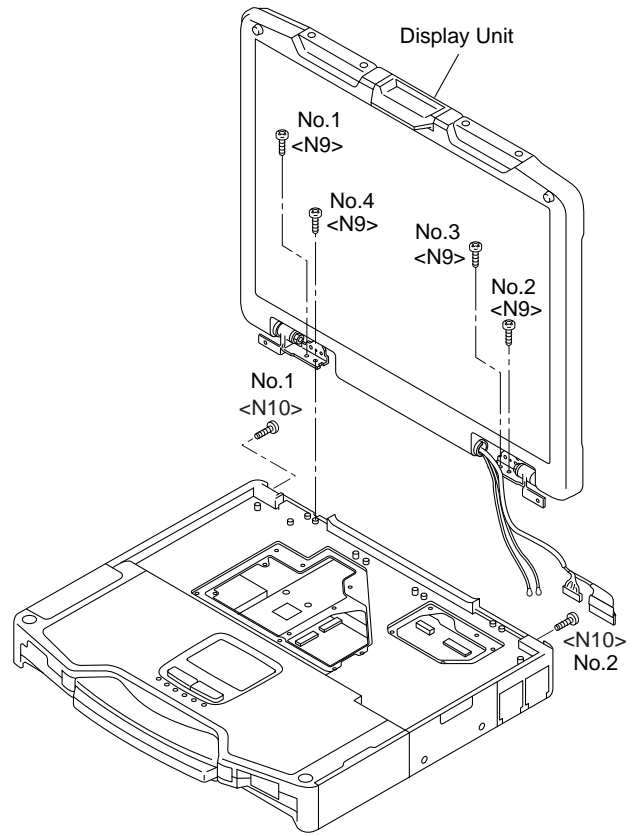

Connection of LCD Cables

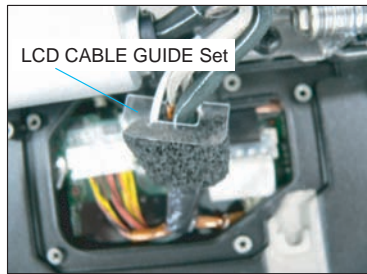

LCD CABLE GUIDE Set

The moran must come over the upper horizontal part of the rib.

The Cables should not be overlapped.

SEC A-A

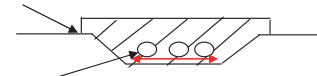

Put LCD CABLE GUIDE on the concave area of the top Cabinet after attaching the Cables. (The Cables are omitted in the picture below.)

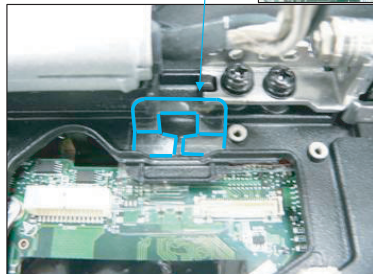

LCD CABLE GUIDE Arranging position (See the left picture.)

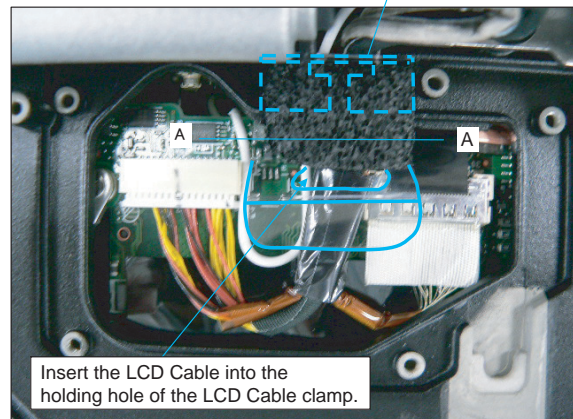

Insert the LCD Cable into the holding hole of the LCD Cable clamp.

9.2.6. Setting the Handle and Power SW

1. Set the WM SW using the 2 Screws <K2-42>
2. Set the Power SW.
3. Set the Handle.
4. Fix the Handle Base L / R using the 2 Screws <K2-41>

Screws <K2-41>: DRSN4+6FKLT
Screws <K2-42>: DXQT26+D4NLT

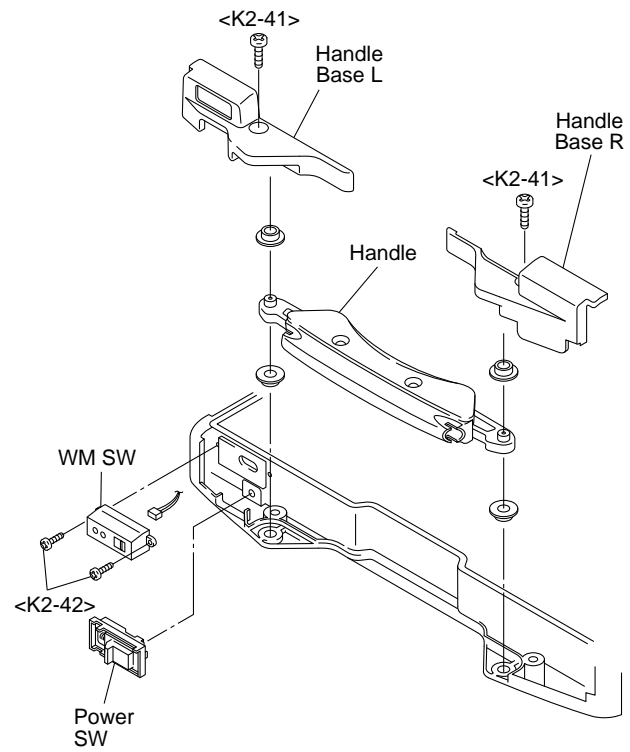

9.2.7. Setting the Palm Top Cover Sheet, Palm Top Cover, Touch Pad Adhesion Seat, Touch Pad SW Knob, LED PCB And SW LED PCB

1. Set the SW LED PCB.
2. Attach the Power LED Packing Sheet to the LED Spacer Sheet.
3. Attach the LEDX6 Spacer Sheet on the SW LED PCB.
4. Fix the SW LED PCB using the Screw <K2-42>.
5. Attach the PW LED Sheet.
6. Pass the Cable of LED PCB through the hole 1 on the Top Cabinet, then set the LED PCB.
7. Attach the LES Spacer Sheet on the LED PCB.
8. Set the touch Pad SW Knob In and Touch Pad SW Knob
9. Attach the TP Bottom Tape to the Touch Pad.
10. Pass the Cables of the Touch Pad through the hole 2 on the Top Cabinet, set the touch Pad.
11. Attach the Touch Pad Adhesion Seat.
12. Fix the Palm Top Cover using the 5 Screws <N29> (No1 to No5).
13. Attach the Palm Top Cover Sheet.

Note:

Tighten the Screws in the numbered order (No1 to No5).

Screws <K2-42>: DRQT26+D4NLT

Screws <N29>: DRQT26+E3FNL

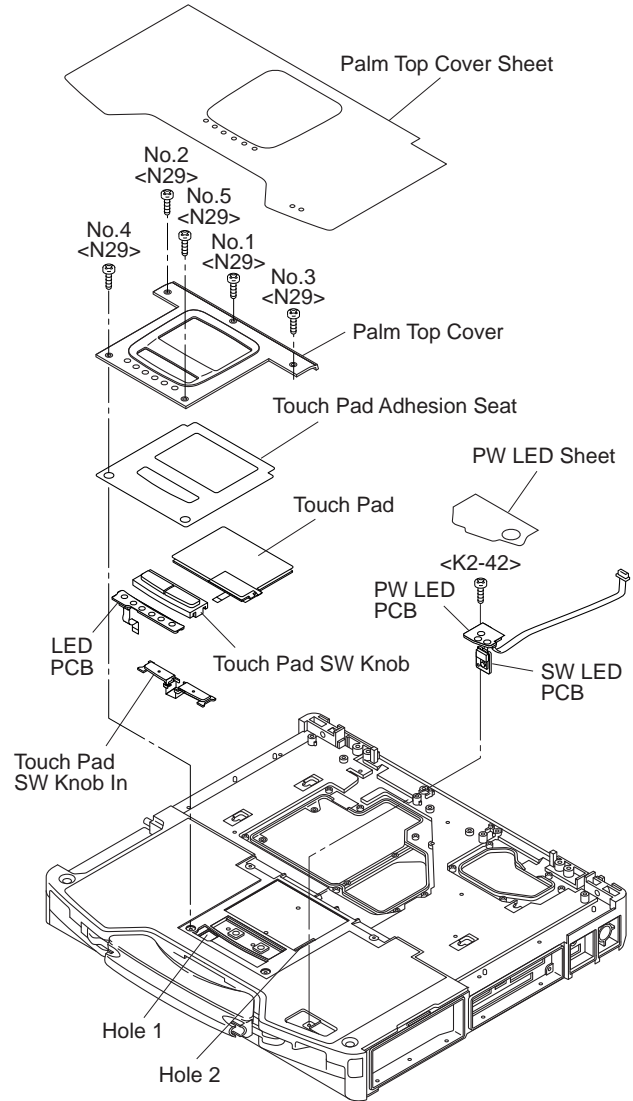

Preparation of SW LED FPC

* Notes:

1. Apply the load when attaching the parts. 20N to 30N (2 to 3Kgf)/cm²

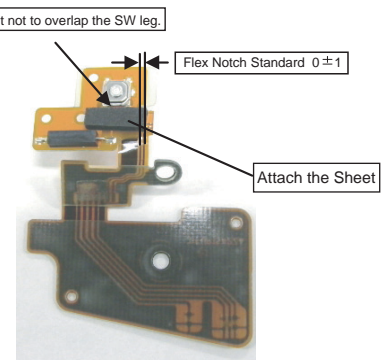
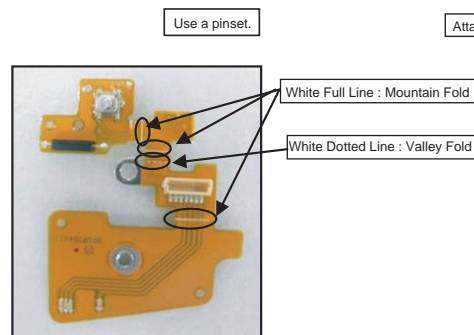
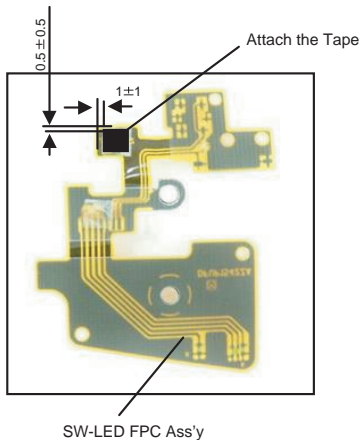

Assembly of Power SW

CAUTION

S1:Insulation S2:Bitten S3:Sharp Edge
S4:Part No. Check S5:Other

* Notes:

1. Apply the load when attaching the parts. 20N ~ 30N (2 ~ 3Kgf)/cm2

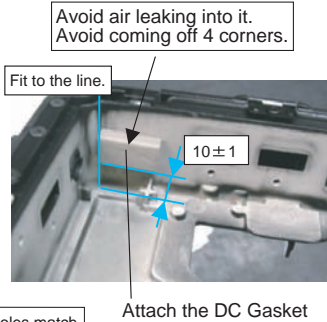
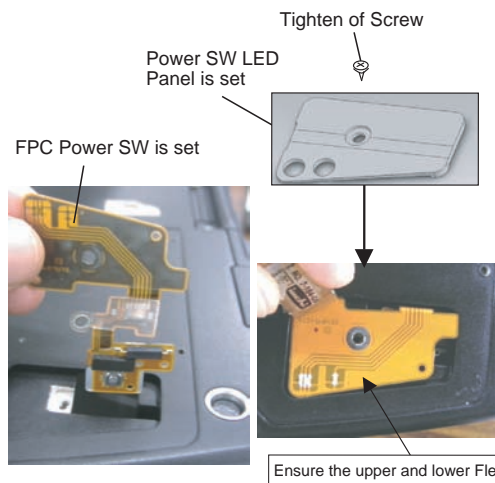
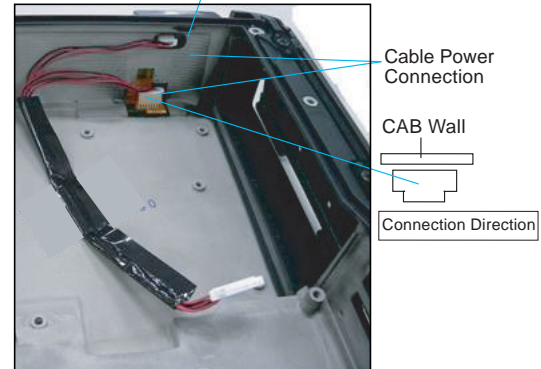
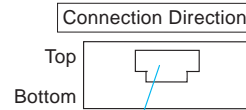
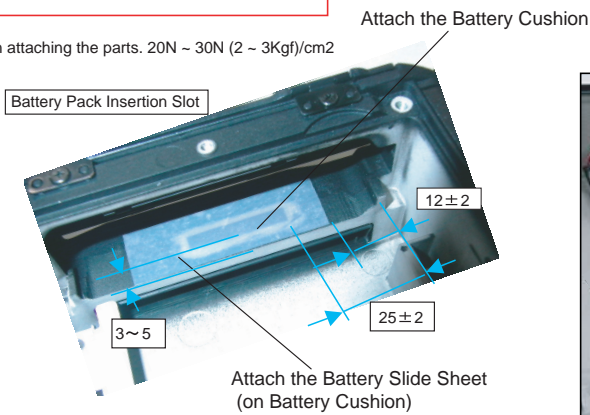

S4 Safety Working

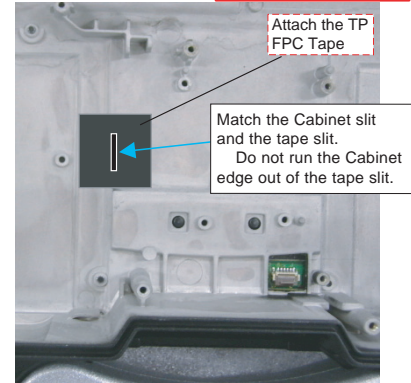

Assembly of Palm Top Cover

Using the pressure jig, Ensure the loads are applied equally. (Make sure the adhesive materials are attached closely on the whole side. Process the speaker lead wire not to put inside when applying the load.

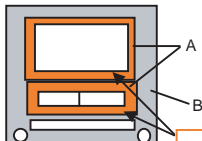

Ensure that the PAD and the button neck are attached with adhesive firmly.

Order of fixing
Screw ①→Screw ②→Screw ③
→Screw ④→Screw ⑤

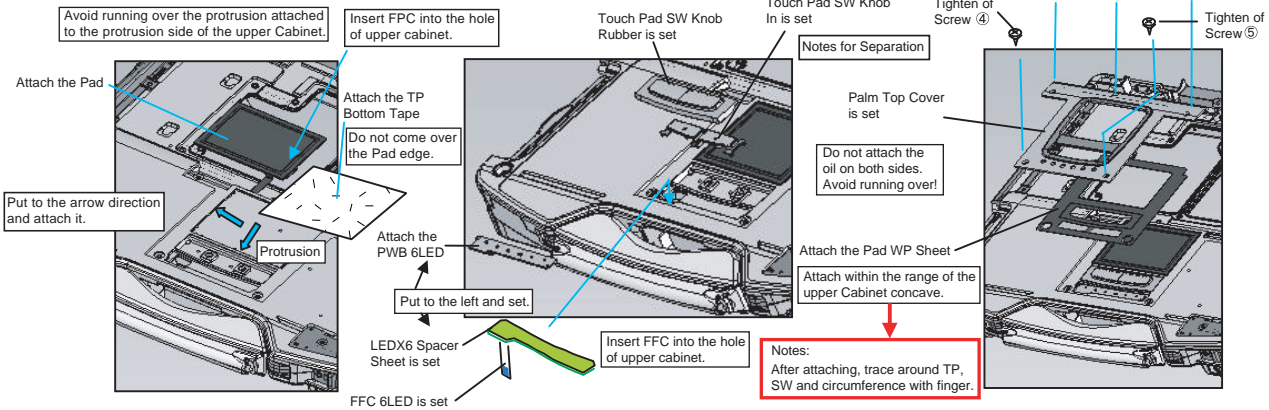

1. Apply the load when attaching the parts. 20N to 30N (2 to 3Kgf)/cm2

9.2.8. Setting the I/O PCB

1. Open the Connector Cover and Lid Cover.
2. Fix the I/O PCB using the 3 Screws <N15> (No1 to No3).
3. Fix the I/O PCB using the 4 Screws <N14> (No1 to No4).
4. Fix the I/O PCB using the 2 Screws <N30> (No1 to No2).

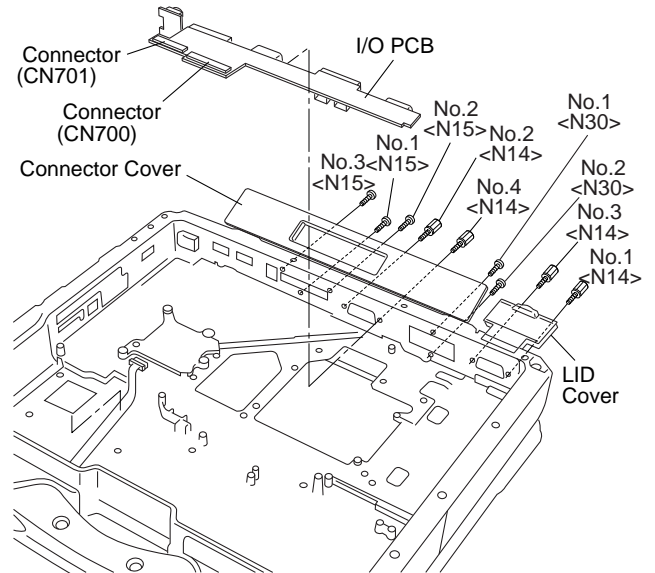

Note:

- Tighten the Screws in the numbered order (No1 to No3).
- Tighten the Screws in the numbered order (No1 to No4).
- Tighten the Screws in the numbered order (No1 to No2).

Screws <N14>: DFHE5058ZB
 Screws <N15>; DRHM5104ZA
 Screws <N30>; DXHM0057ZA

Assembly of I/O SUB PCB

<Notes>

1. Apply the load when attaching the attaching parts. 20~30N (2~3Kgf)/cm²
 Reusing the attaching parts is impossible
 Torque of tightening screw : 0.19 ± 0.02N·m (≈ 1.9 ± 0.2kgf·cm)

CAUTION	S1:Insulation S2:Bitten S3:Sharp Edge S4:Part No. Check S5:Other
----------------	---

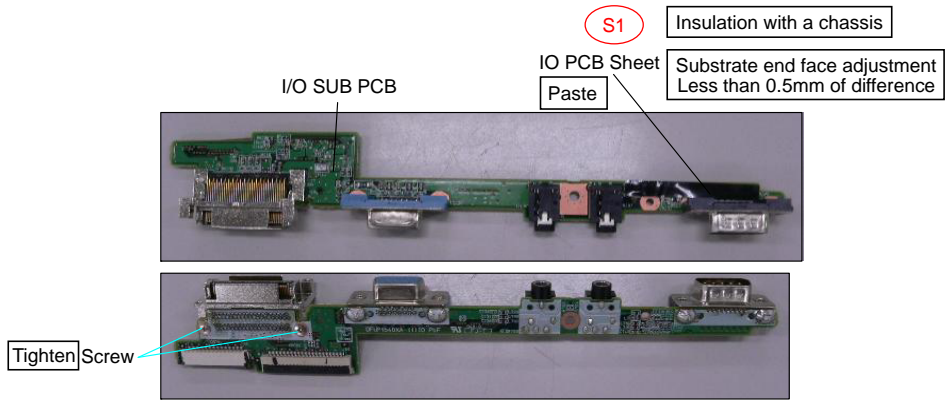

9.2.9. Setting the SD PCB, Express Card and PCMCIA Card

1. Fix the PCMCIA Card using the 4 Screws <N22> (No1 to No4).
2. Fix the Express Card using the 4 Screws <N22> (No1 to No4).
3. Fix the SD PCB using the 2 Screws <N5> (No1 to No2).

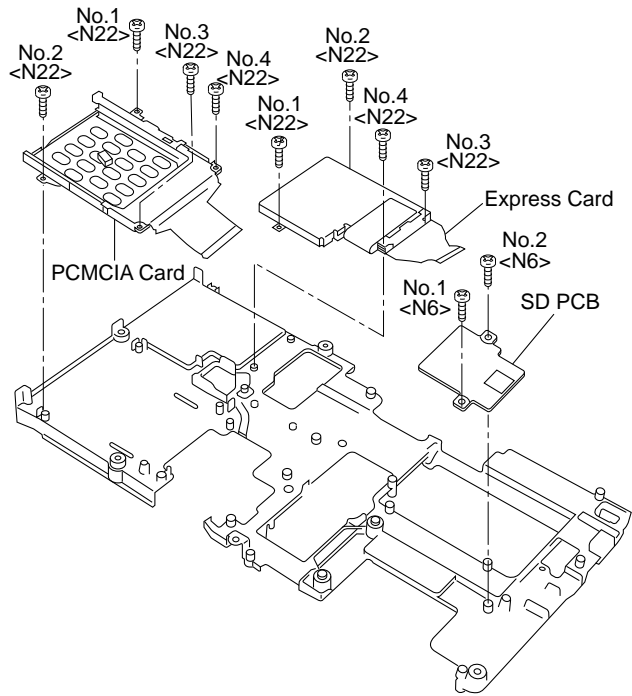

Note:

- Tighten the Screws in the numbered order (No1 to No4).
- Tighten the Screws in the numbered order (No1 to No4).
- Tighten the Screws in the numbered order (No1 to No2).

Screws <N6>: DRQT26+E4FKL

Screws <N22>: DXQT2+G4FNL

Preparation of PCMCIA Card Connector

<Notes>

1. Apply the load when attaching the attaching parts. 20~30N (2~3Kgf)/cm2
Reusing the attaching parts is impossible

CAUTION

S1:Insulation S2:Bitten S3:Sharp Edge
S4:Part No. Check S5:Other

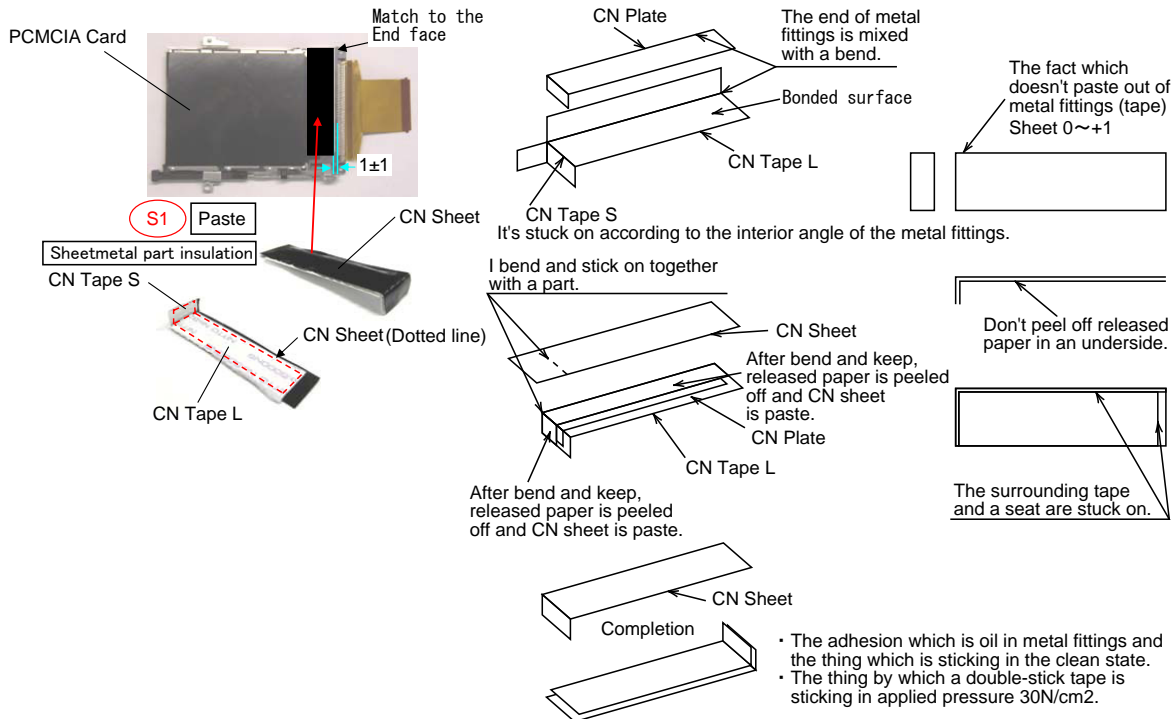

9.2.10. Setting the Main PCB

1. Fix the Main PCB using the 8 Screws <N32> (No1 to No8), Screw <N6> (No1 to No2) and Screw <N11>.
2. Set the Modem Cable.
3. Connect the Cable to the Connector (J2) and fix the MDC.
4. Attach the Tape.
5. Attach the 1394 Sheet.
6. Fix the MDC using the 2 Screws <N11> (No1 to No2).
7. Fix the Modem LAN Case using the 2 Screws <N32> (No1 to No2).
8. Attach the 2 Modem Cable Sheets.

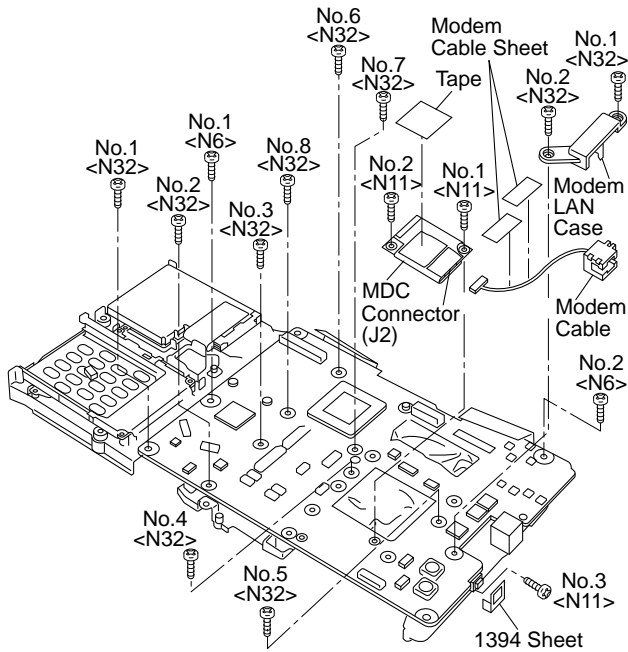

9. Connect the Cable to the Connector (CN4,CN11).
10. Attach the Tape.
11. Attach the Coin Battery.
12. Connect the Cable to the Connector (CN19).
13. Attach the Coin Battery Cushion.
14. Fix the MP PCB and MP Guide using the 2 Screws <N6> (No1 to No2) and 2 Screws <N21> (No1 to No2).

15. Connect the Cable to the Connector. (CN400,CN401)
16. Set the Main Chassis on the Computer.
17. Attach the Tape.

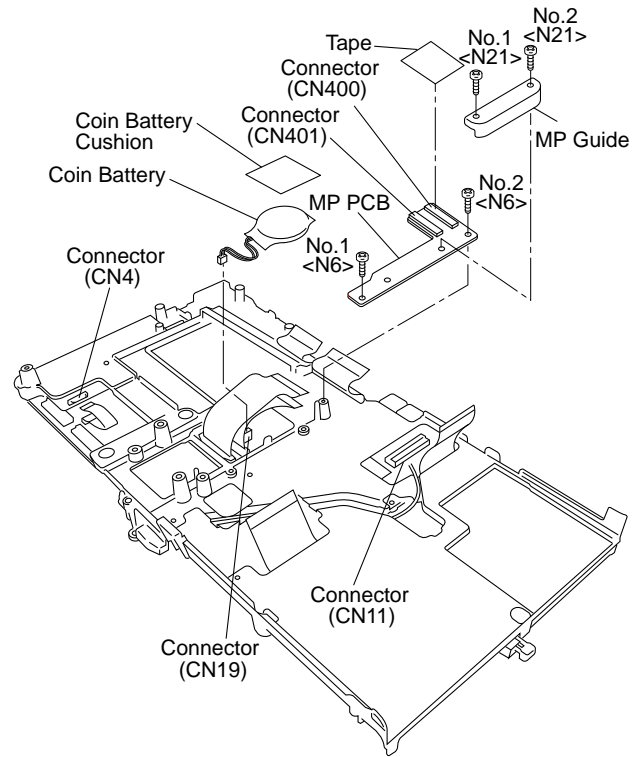

18. Connect the Cable to the Connector (CN31) and Attach the Pet Tape.
19. Connect the Cable to the Connector (CN700,CN701).
20. Fix the Main Chassis using the 6 Screws <N16> (No1 to No6)
21. Fix the Main Chassis using the Screw <N18>.

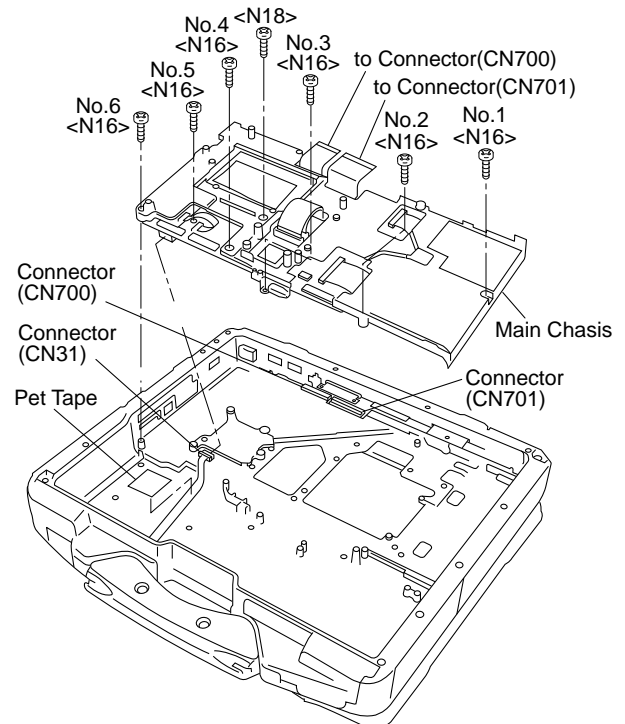

22. Connect the 2 Cables to the 2 Connectors (CN17,CN27).
23. Attach the TOP WP Washer and tighten the Screw <N7>.
24. Attach the TOP Screws Sheet.

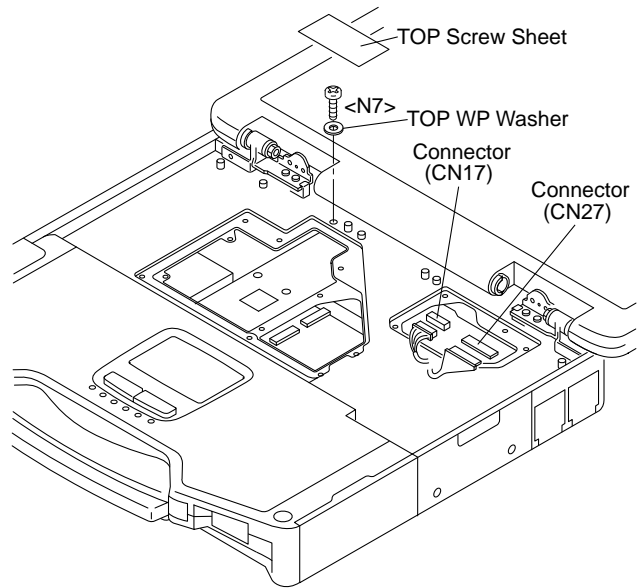

Preparation of MODEM and MDC

<Notes>

1. Apply the load when attaching the attaching parts. 20~30N (2~3Kgf)/cm2
Reusing the attaching parts is impossible

CAUTION	S1:Insulation S2:Bitten S3:Sharp Edge S4:Part No. Check S5:Other
----------------	---

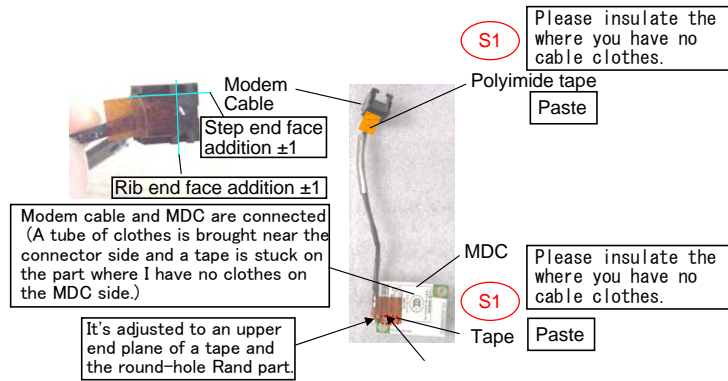

Assembly of LAN, Modem and MDC

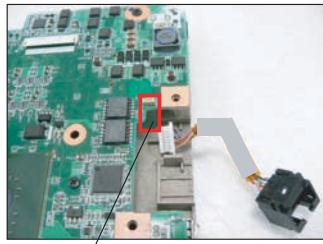

Pass the Cable to the back from the hole of the A side.

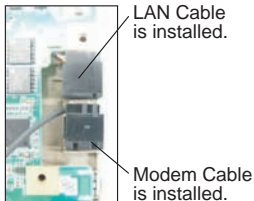

LAN Cable is installed.

Modem Cable is installed.

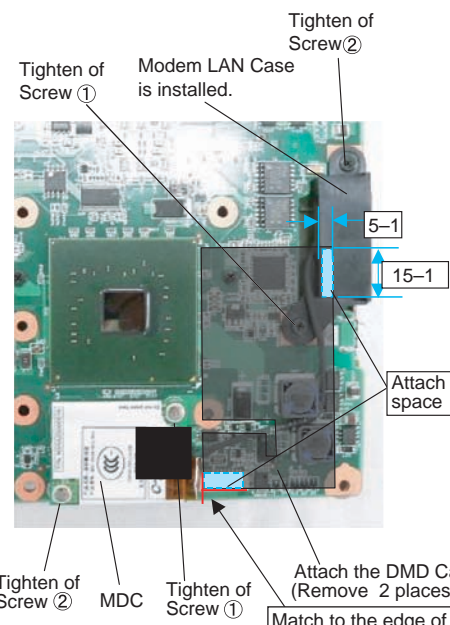

Order of fixing
Screw①→Screw②

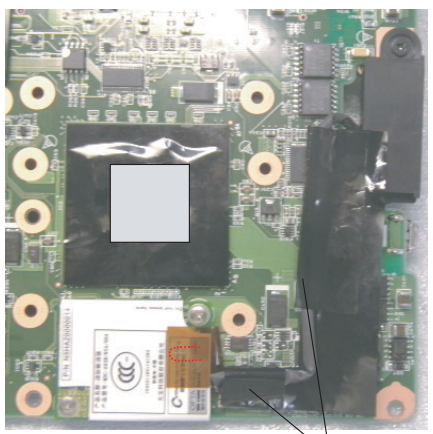

Process the cable and cover with MDM Cable Sheet

* Notes:

1. Apply the load when attaching the parts. 20N to 30N (2 to 3Kgf)/cm2

CAUTION S1:Insulation S2:Bitten S3:Sharp Edge S4:Part No. Check S5:Other

Safety Working

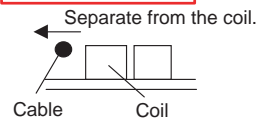

<Notes>

1. Apply the load when attaching the attaching parts. 20~30N(2~3Kgf)/cm2
Reusing the attaching parts is impossible

CAUTION S1:Insulation S2:Bitten S3:Sharp Edge S4:Part No. Check S5:Other

The thing entourage open more than 1.5mm (for the design value, 3mm)

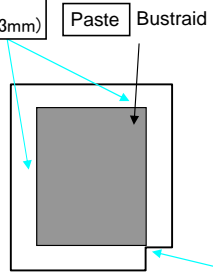

S1
Corner adjustment
I don't stick out

Part end face adjustment
Substrate concave department

Paste Bustraid Sheet
Substrate end face adjustment
Substrate concave department

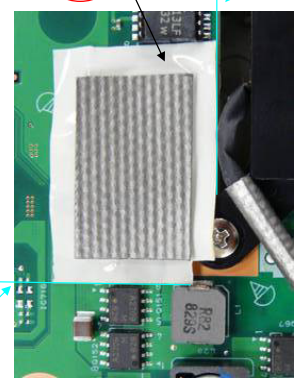

Assembly of Main PCB

* Notes:

1. Apply the load when attaching the parts. 20N ~ 30N (2 ~ 3Kgf)/cm2

To prevent the mounted parts from touching the Steel Plate.

Cable SATA Signal Insertion
Insert the connector wrapped with the sheet into the connector on the board.

S3

Bend the cable avoiding the connector.

Safety Working
Attach the PET Sheet

To prevent the Part edge from touching the Card FPC.

1 ~ 2

Safety Working
Sheet wrap

CAUTION

S1:Insulation S2:Bitten S3:Sharp Edge
S4:Part No. Check S5:Other

Connect the LAN cable.

Put the cable in a U-shape into the intermediate chassis aperture next to the connector.

Do not pinch the cable out of the USB PCB.

Safety Working S2

MCH HEAT RUBBE Set

MCH INS SHEE Set

CHASSIS

0-2

0-0.5

PWB SHEET Attach.
Fold and attach the back side.

Fix with Screws in order of the rear number of No.
Ex.) Fix in order of ㉓-1 to ㉓-2.

(Notes)

1. Apply the load when attaching the attaching parts. 20~30N (2~3Kgf)/cm2
2. Reusing the attaching parts is impossible.

9.2.11. Setting the PAD PCB

1. Fix the PAD PCB using the 2 Screws <N29> (No1 to No2).
2. Attach the TP PCB Screw Sheet.
3. Connect the Cable to the Connector. (CN802)
4. Connect the Cable to the Connector (CN801) and attach the Tape.

Note:

Tighten the Screws in the numbered order (No1 to No2).

Screws <N29>: DRQT26+E3FNL

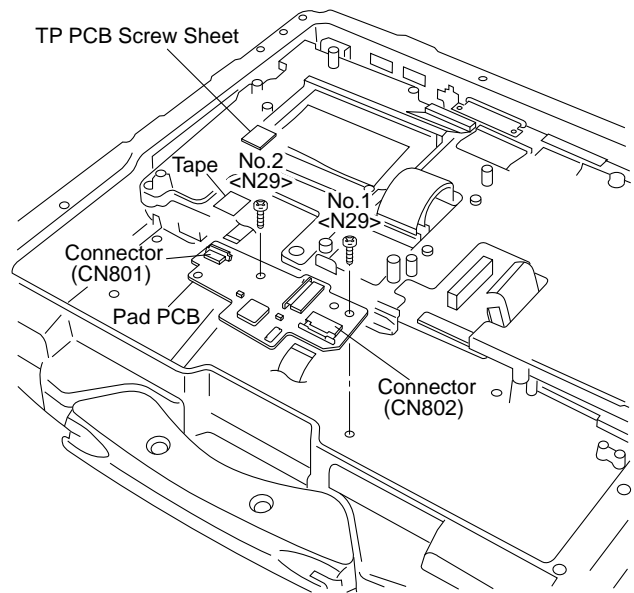

Assembly of PAD PCB

1. Apply the load when attaching the attaching parts.
20 to 30N (2 to 3Kgf)/cm²
2. Reusing the attaching parts is prohibited.
Tightening torque

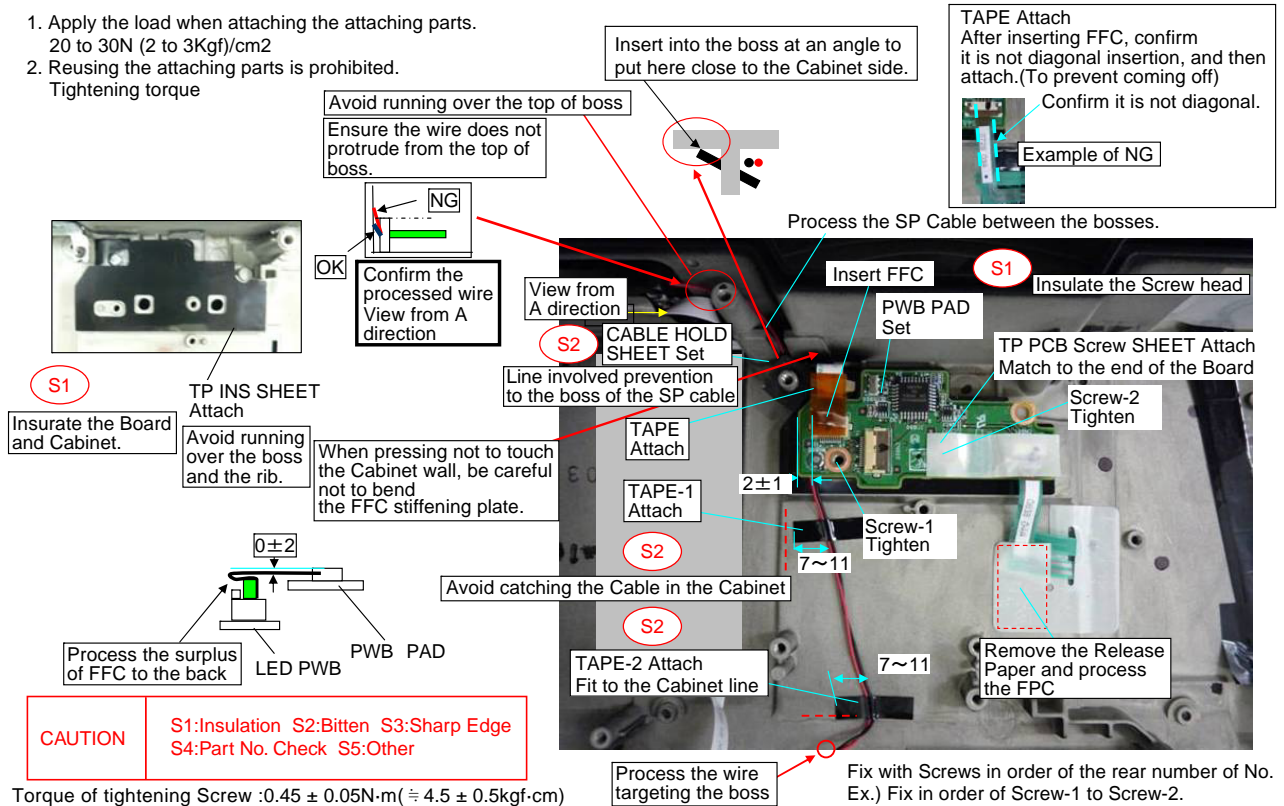

9.2.12. Setting the FPC HDD BAT

1. Fix the FPC HDD BAT using the Screw <N16>.
2. Connect the 2 Cables to the 2 Connectors (CN7,CN8).
3. Connect the Cable to the Connector (CN800).
4. Attach the PAD Protect Sheet.
5. Connect the Cable to the Connector (CN9).
6. Attach the Tape.
7. Connect the 2 Cables to the 2 Connectors (CN10,CN26).
8. Attach the Tape.
9. Attach the Antenna Cable Sheet on the Main PCB.
10. Fix the HDD FPC BAT using the 3 Screws <N29> (No1 to No4).

Note:

Tighten the Screws in the numbered order (No1 to No4).

Screw <N16>: DRQT26+E5FKL

Screw <N29>: DRQT26+E3FNL

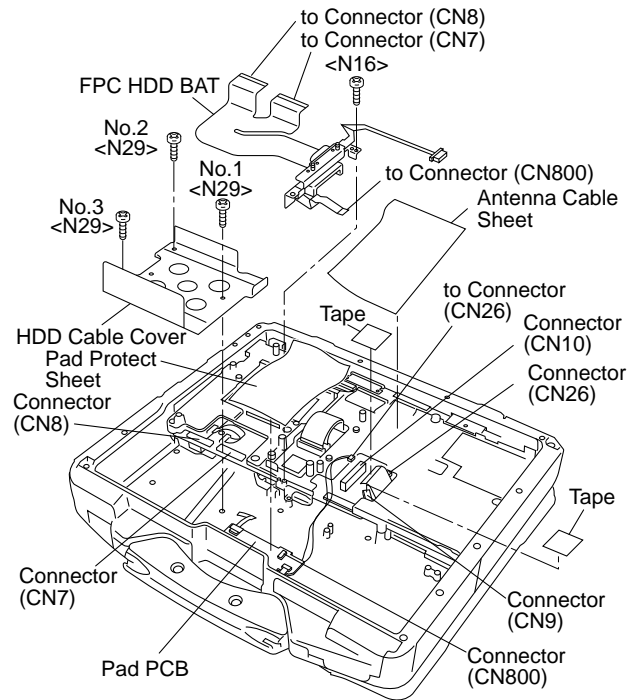

Preparation of HDD FPC ASS'Y

CAUTION S1:Insulation S2:Bitten S3:Sharp Edge
S4:Part No. Check S5:Other

Fold mountain based on the white line.
R0.5 to R1
Do not apply the load on the folding part.
Do not forget folding

Tape Attach based on the stiffening plate side and fold back to the back side.
(Avoid wrinkle or floating.)
Apply the load. 2 to 3 kg

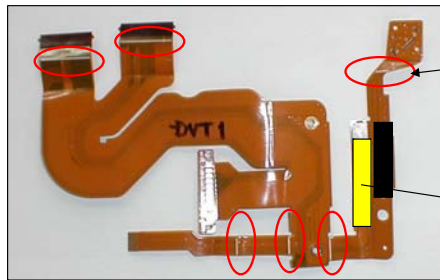
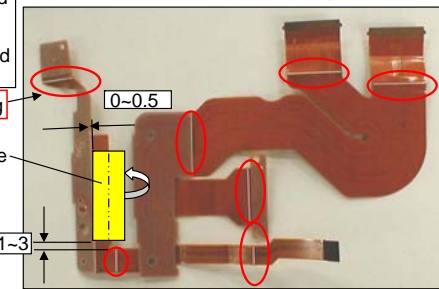

Tape Attach based on the stiffening plate side and fold back to the back side.
(Avoid wrinkle or floating.)
Apply the load. 2 to 3 kg

Fix with Screws in order of the rear number of No. Ex.) Fix in order of Screw-1 to Screw-2.

Screw-2 Tighten
Screw-1 Tighten

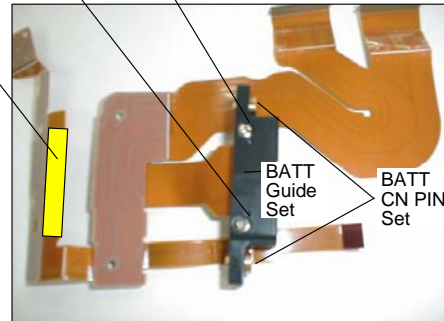

Do not forget folding

BATT CN PIN Cushion Set

Tape
S3

Torque of tightening Screw : $0.19 \pm 0.02\text{N}\cdot\text{m}$ ($\approx 2.0 \pm 0.2\text{kgf}\cdot\text{cm}$)

CAUTION S1:Insulation S2:Bitten S3:Sharp Edge
S4:Part No. Check S5:Other

Torque of tightening screw : $0.19 \pm 0.02\text{N}\cdot\text{m}$ ($\approx 2.0 \pm 0.2\text{kgf}\cdot\text{cm}$)

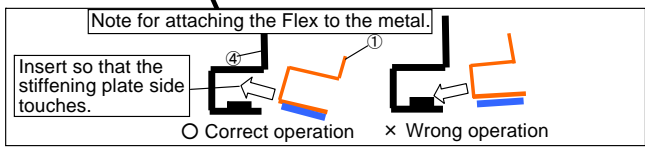
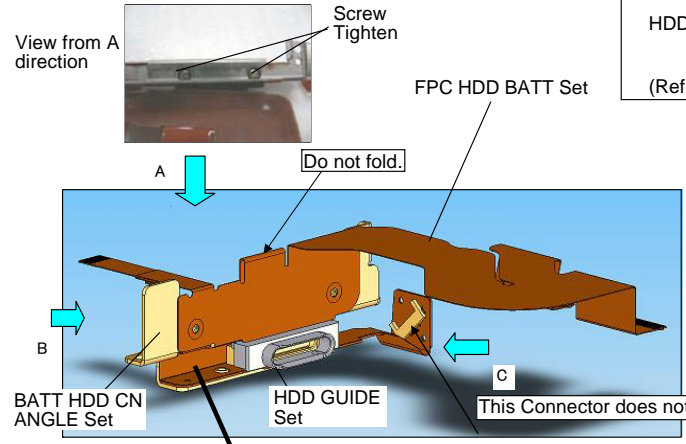

1. Set HDD GUIDE and fix with Screw.
2. Fix with Screw.
3. Apply tetra coating to each Connector pin.
 Battery Connector : Set the nozzle tip apart from the Connector with 1 to 10 mm and spray from the Connector end to the end for about 1 minute. Do the same to the opposite direction.
 HDD Connector : Set the nozzle tip apart from the Connector with 1 to 10 mm and spray from the Connector end to the end one way for about 1 minute.
 (Refer to M14 in "Common Assembly Instruction Manual".)

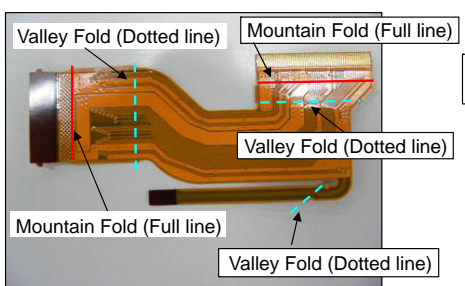
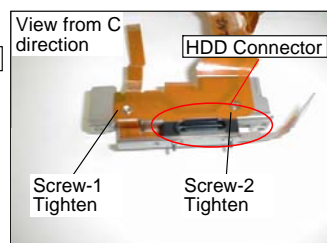
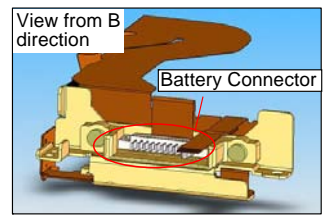

Fold along the level of the outer shape.

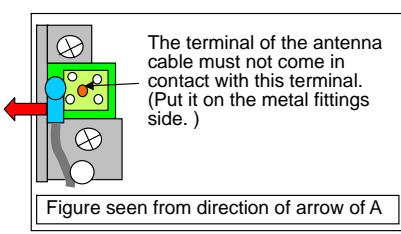
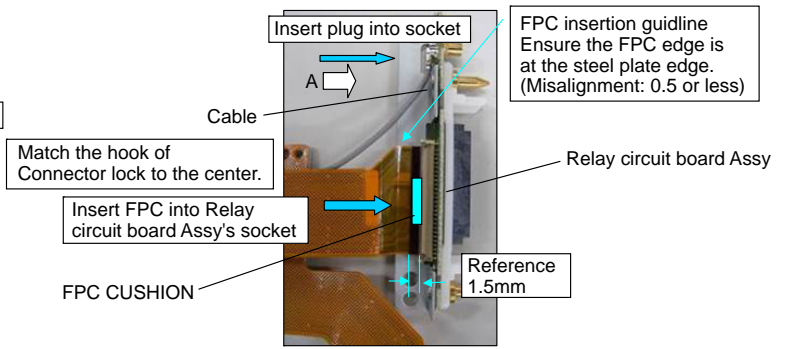
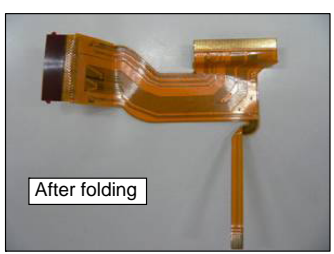

Lock after inserting FPC.
Lock FPC

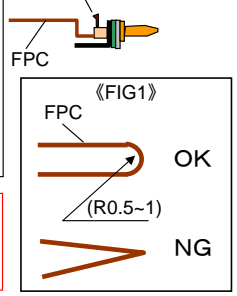

- 《The attention of folding》 : Breakage countermeasure.
1. The bending inside is R0. 5~1 《FIG1》
 2. Don't mistake a bending direction.
Don't use a mistaken thing.

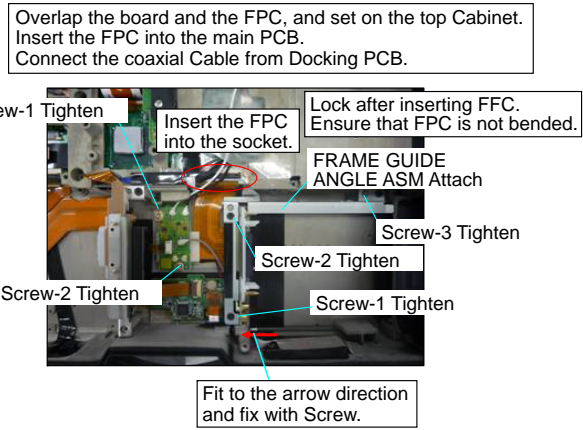
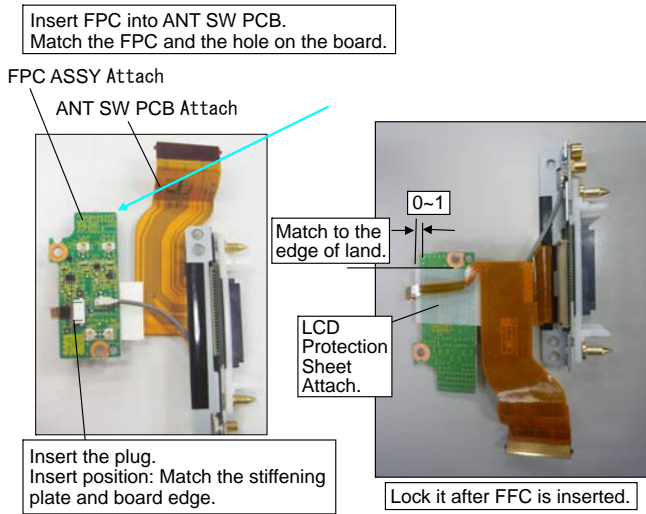

Torque of tightening Screw : $0.45 \pm 0.05\text{N}\cdot\text{m}$ ($\approx 4.5 \pm 0.5\text{kgf}\cdot\text{cm}$)

9.2.13. Setting the USB PCB and Antenna PCB

1. Open the Connector Cover.
2. Fix the Antenna PCB using the 2 Screws <N3> (No1 to No2).
3. Connect the Black Cable.
4. Fix the USB PCB using the Screws <N6>.
5. Connect the Cable to the Connector (CN100).
6. Attach the Tape.

Note:

Tighten the Screws in the numbered order (No1 to No2).

Screws <N3>: DRQT2+G6FKL
Screws <N6>: DRQT26+E4FKL

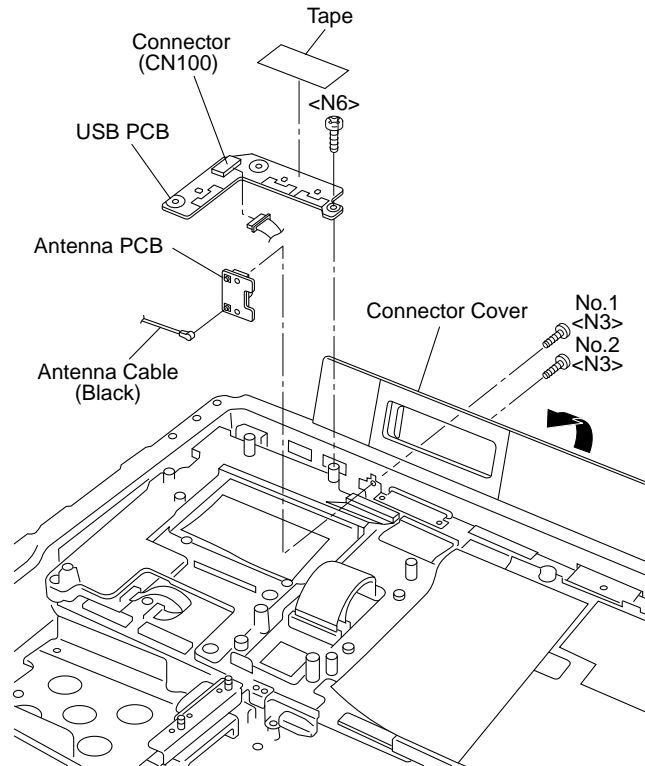

Assembly of USB / Antenna PCB

CAUTION S1:Insulation S2:Bitten S3:Sharp Edge
S4:Part No. Check S5:Other

(Notes)
1. Insert and remove plug straight
2. Don't make covering damaged at the time of cable handling.

I Attach SHEET to Cable
54~56 Cable
SHEET Attach.

II Connect Cable into the CN2 of EXT ANT PCB and process the wire.

III Attach EXT ANT PCB to the Cabinet and fix with Screw.

SCREW-1 Tighten
SCREW-2 Tighten

EXT ANT PCB Set

Ensure the Flex tag does not run over.

Fit to the groove. Misalignment: 1 or less

Pass the Cable along the intermediate chassis concave and connect it to the coaxial Connector.

S2

SHEET Attach.

Match to the edge. Misalignment: 2 or less

WHIP ANT CABLE

Insert the Cable plug.

CABLE (DFJS1055ZA)

FPC Edge Standard 1±1

ANT CABLE SHEET Attach.

SCREW Tighten

ANT CABLE PLATE Set

<Notes>
1 Apply the load when attaching the attaching parts. 20~30N (2~3Kgf)/cm2
Reusing the attaching parts is impossible

CAUTION S1:Insulation S2:Bitten S3:Sharp Edge
S4:Part No. Check S5:Other

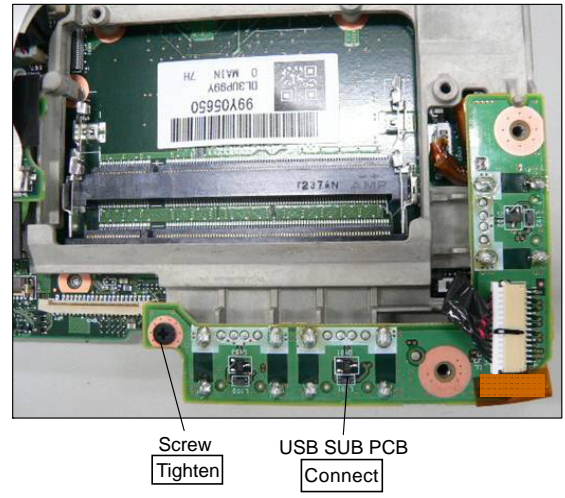

Substrate end face addition. Difference less than 1

CN end face addition. Difference less than 1

CD Edge Sheet Polymide tape Paste S1

Insulation with a gasket (cabinet)

USB Cable Connect

Torque of tightening screw : 0.2 ± 0.02N·m (≒ 2.0 ± 0.2kgf·cm)

9.2.14. Setting the DIMM Cover and Bottom Cover

1. Set the Bottom Cover.
2. Fix the Bottom Cover using the 6 Screws <N8> (No1 to No6).
3. Fix the Bottom Cover using the 2 Screws <N17> (No1, No2).
4. Fix the Bottom Cover using the 13 Screws <N6> (No1 to No13).
5. Set the DIMM memory card.
6. Attach the DIMM Heat Plate.
7. Fix the DIMM Stopper Base using the 2 Screws <N6>.
8. Fix the DIMM Cover using the 5 Screws <N1>.

Screws <N1>: DRHM0002ZA
 Screws <N5>: DRQT26+D4FKL
 Screws <N6>: DRQT26+E4FKL
 Screws <N8>: DRSB3+8FKL
 Screws <N17>: DRQT26+E6FKL

Note:
 Tighten the Screws in the numbered order (No1 to No6).
 Tighten the Screws in the numbered order (No1 to No13).
 Tighten the Screws in the numbered order (No1 to No5).

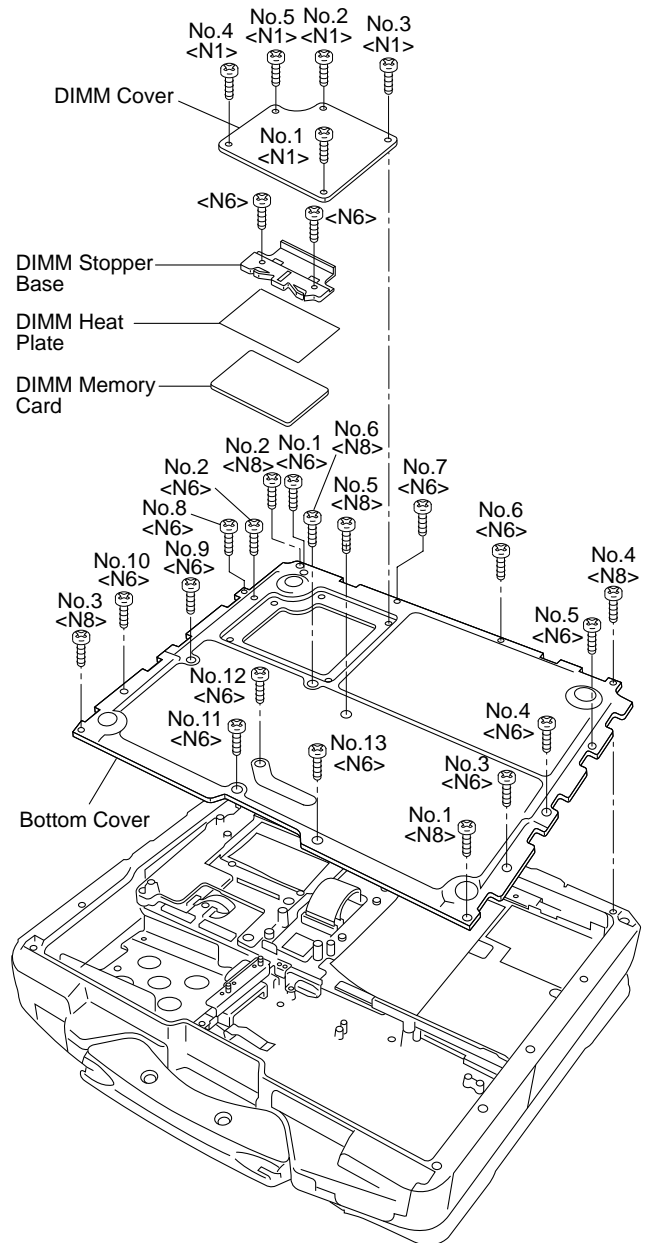

Preparation of DIMM Cover

* Notes:

1. Apply the load when attaching the parts. 20N to 30N (2 to 3Kgf)/cm²

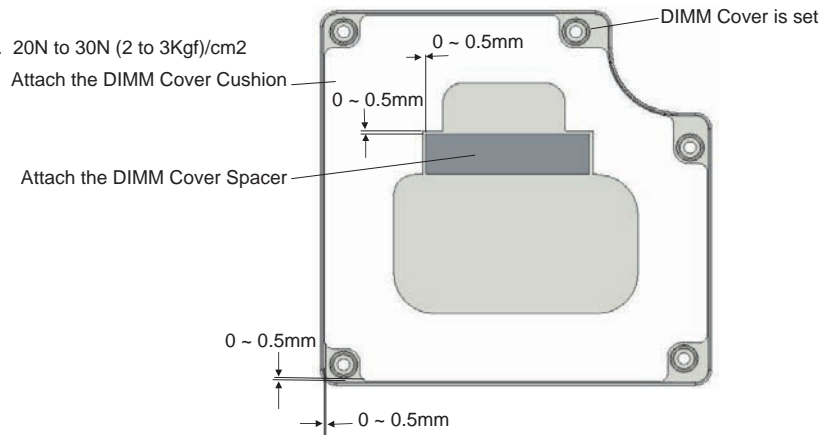

9.2.15. Setting the W-LAN Module, GPS PCB and Bluetooth PCB

1. Set W-LAN Module.
2. Fix the W-LAN Module using the 2 Screws <N11> (No1 to No2).
3. Connect the Antenna Cables to the Connector on W-LAN Module.

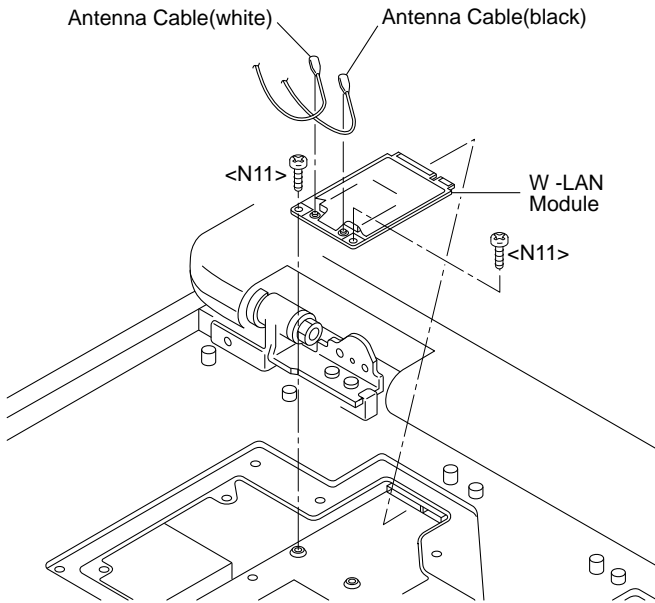

4. Fix the GPS BT Angle and GPS PCB using the 2 Screws <N11> (No1 to No2).
5. Connect the Cable to the Connector on GPS PCB.
6. Fix the GPS Ass'y using the 4 Screws <N12> (No1 to No12).

7. Connect the Cable to the Connector (CN25).

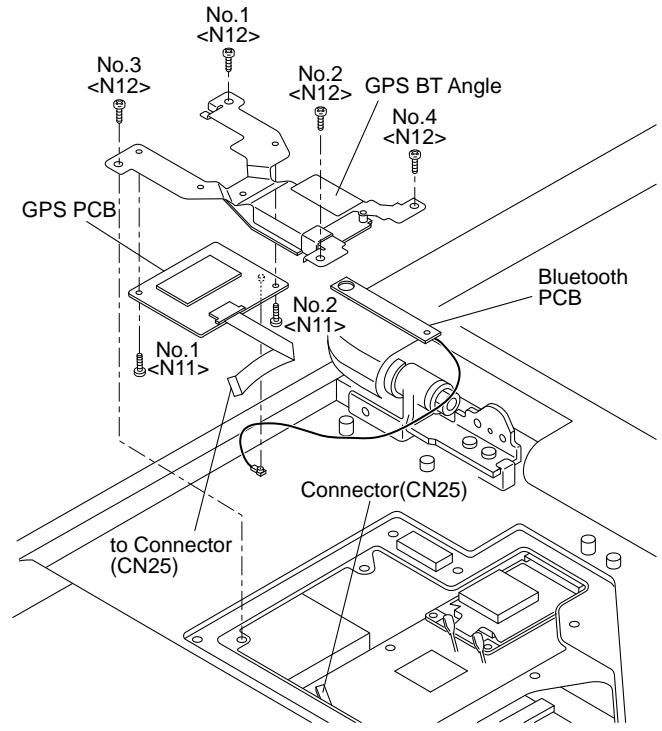

Screws <N11>: DFHE5025XA
Screws <N12>: DXQT2+F3FNL

Note:

- Tighten the Screws in the numbered order (No1 to No2).
- Tighten the Screws in the numbered order (No1 to No2).
- Tighten the Screws in the numbered order (No1 to No12).

Preparations and assembly of W-LAN Module

「512AN MMW」 Confirm the printing.

S4

How to discriminate the Wireless LAN card
For North America and Europe N5HZC0000042



CAUTION

S1:Insulation S2:Bitten S3:Sharp Edge
S4:Part No. Check S5:Other

Torque of tightening screw :0.19 ± 0.02N·m (≒ 2.0 ± 0.2kgf·cm)

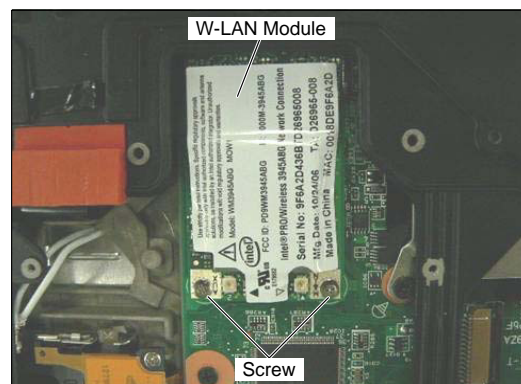
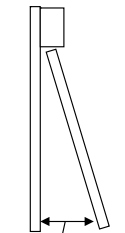

Cautions for Setting GPS ASSY and BT PCB ASS'Y

<Notes>

1. Do not gouge when inserting and removing the plug.
2. Do not damage the coating when handling the Cable.

CAUTION

S1:Insulation S2:Bitten S3:Sharp Edge
S4:Part No. Check S5:Other

S2

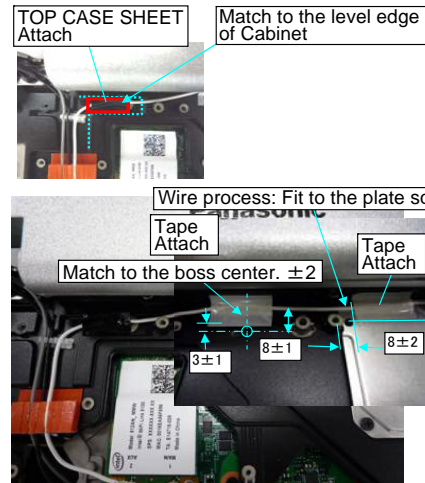
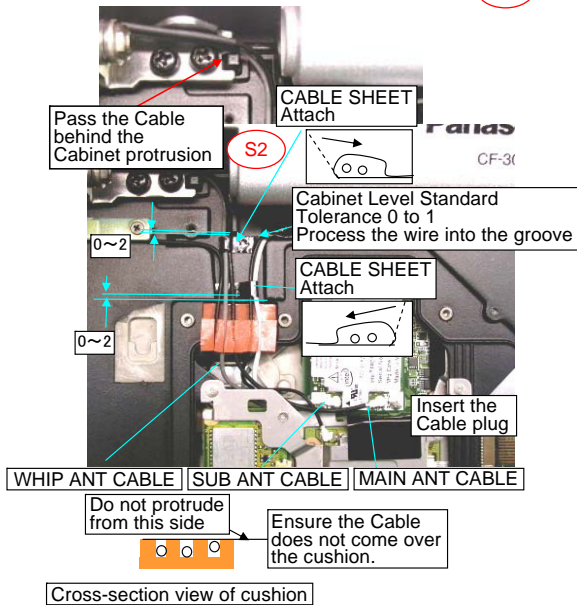

<Note>

- Each Cable must fit in the slit of ANT Cable cushion securely.
- The Cable must not cross at the ANT Cable cushion part.

9.2.16. Setting the KB Cable Cover, Keyboard and LCD Cable Cover

1. Set the Keyboard on to the Computer.
2. Connect the 2 Cables to the 2 Cables (CN13,CN14).
3. Fix the KB Cable Cover using the 7 Screws <N29> (No1 to No7).
4. Fix the LCD Cable Cover using the 3 Screws <N29> (No1 to No3).

Note:

- Tighten the Screws in the numbered order (No1 to No7).
- Tighten the Screws in the numbered order (No1 to No3).

Screws <N29>: DRQT26+E3FNL

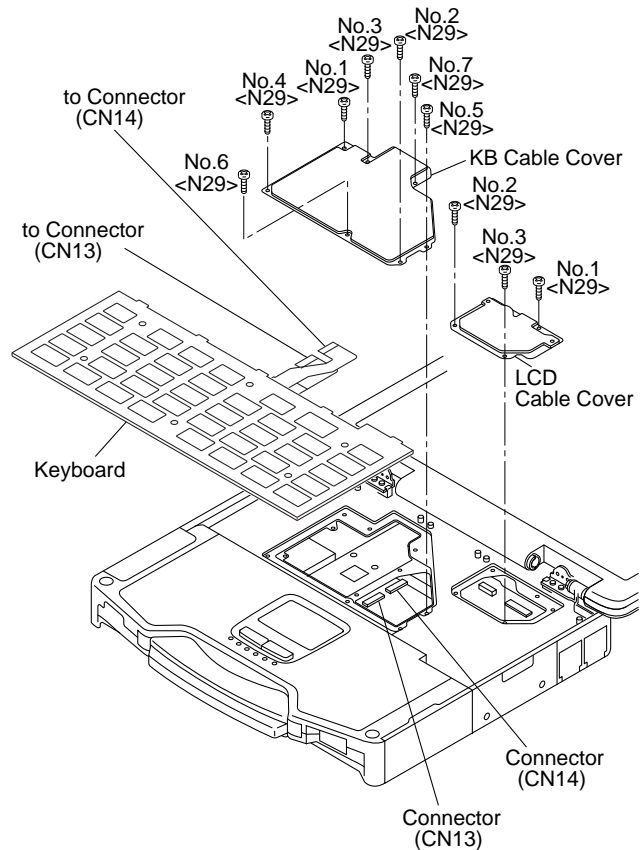

Arranging the Keyboard

Conductive Cloth Paste

0.5

0.5

0.5

Conductive Cloth Paste

Keyboard is installed

Attach the Keyboard Spacer Tape

Attach the Keyboard Back Plate

Attach the Keyboard Spacer Sheet

Plate hole

1. Attach Keyboard , Keyboard Spacer Tape and Keyboard Back Plate. (Insert the KB protrusions into the plate holes and determine the position.)
2. Attach Conductive Cloth to Keyboard Back Plate.
3. Attach Keyboard Spacer Sheet to Keyboard Back Plate. (Ensure Keyboard Spacer Sheet does not run over the level of Keyboard Back Plate.)

<Notes>
1. Apply the load when attaching the attaching parts. 20~30N (2~3Kgf)/cm2
Reusing the attaching parts is impossible

Assembly of LCD Cable Plate

CAUTION S1:Insulation S2:Bitten S3:Sharp Edge S4:Part No. Check S5:Other

DFHR3M83ZA

LCD CABLE COVER CUSHION

KB CABLE COVER CUSHION

S3

(Notes)
1. Apply the load when attaching the attaching parts. 20~30N (2~3Kgf)/cm2

LCD CABLE COVE Set

LCD CABLE COVER CUSHION Attach.

KB CABLE COVE Set

KB CABLE COVER CUSHION Attach.

CD Edge Sheet Attach. 0~1mm

To prevent from touching the KBD Cable 4~6mm

9.2.17. Setting the KB Cover, Hinge Cover L, Hinge Cover R and Keyboard

1. Insert the front hooks of the Keyboard to the Top Cabinet in order, and set the Keyboard.
2. Fix the Hinge Cover L and R using the 3 Screws <N6> (No1 to No3).
3. Fix the Hinge Cover L and R using the 2 Screws <N2> (No1, No2)
4. Fix the Bluetooth PCB using the Screw <N6>.
5. Fix the KB Cover using the 4 Screws <N6> (No1 to No4).

Note:

- Tighten the Screws in the numbered order (No1 to No3).
- Tighten the Screws in the numbered order (No1 to No2).
- Tighten the Screws in the numbered order (No1 to No4).

Screws <N2>: DRHM5054XA
Screws <N6>: DRQT26+E4FKL

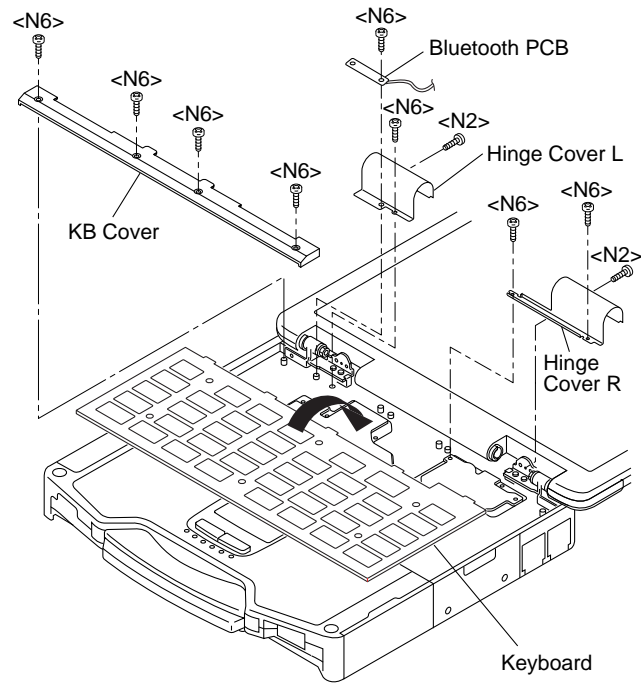

9.2.18. Setting the HDD

1. Set the HDD FPC to HDD.
2. Attach the Heater Ins Sheet and Sheet to HDD.
3. Attach the Heater to HDD.
4. Attach the 6 HDD Forming MFYPC and the two HDD Terminal Plate Upper to the HDD Damper Ass'y.
5. Attach the six HDD Forming MFYPC and the two HDD Terminal Plate Upper to the HDD Damper Ass'y.
6. Set the HDD Damper Ass'y to HDD.
7. Attach the Side Cushion to the HDD L Case Ass'y.
8. Set the HDD U Case Ass'y and the HDD L Case Ass'y, and set the two Tabs of the HDD L Case Ass'y.
9. Fix the HDD U Case Ass'y and the HDD L Case Ass'y using the 4 Screws <K1-17> and Screw <K1-16>.

Screws <K1-16>: DFHE5025XA
Screws <K1-17>: DRQT2+E8FKL

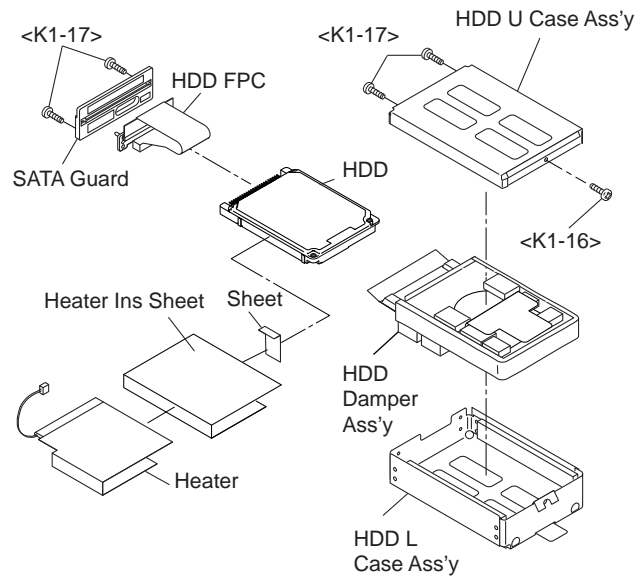

Preparation oh HDD ASS'Y

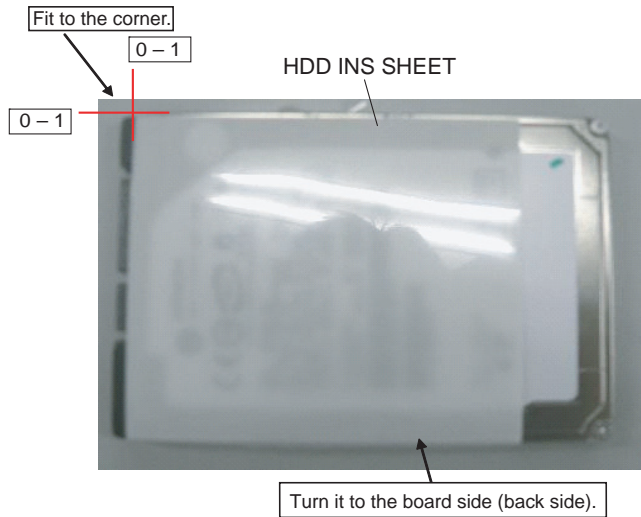

- * Notes:
 1. Apply the load when attaching the parts. 20N to 30N (2 to 3Kgf)/cm2



Safety Working

S4 HEATER

Attach it pushing the shaded part not to push the fuse.

CAUTION

S1:Insulation S2:Bitten S3:Sharp Edge
 S4:Part No. Check S5:Other

1. Do not gouge when inserting and removing the socket.
2. Do not drop HDD or add any impacts on it.
3. Insert CN into the end firmly.
4. Apply the load when attaching the parts. 20N to 30N (2 to 3Kgf)/cm2

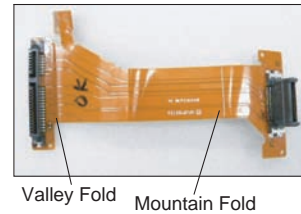
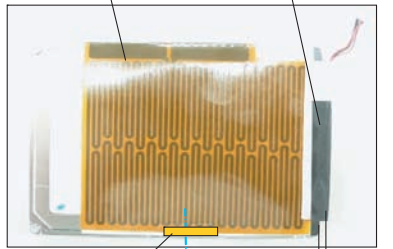
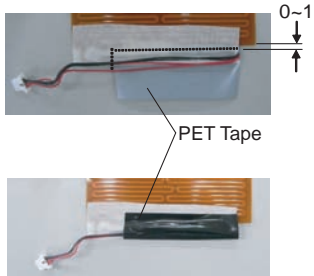

Do not bend the bending part of Heater

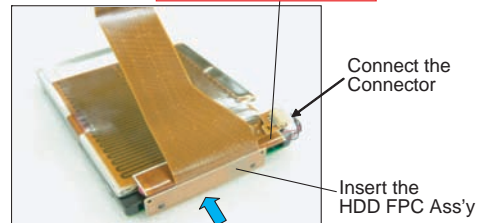
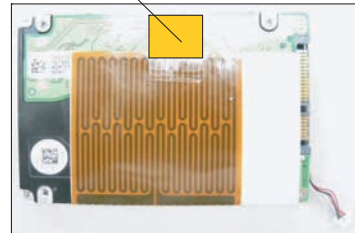

* Notes:

1. Apply the load when attaching the parts. 20N to 30N (2 to 3Kgf)/cm²

S2 Do not place the damper over the plate of FPC.

Do not place the damper over the plate of heater.

HDD Damper Ass'y

Make sure the product with black sheet on the yellow sponge.

Fold the FPC from the board edge.

HDD Ass'y HDD Set Insert after removing the Release Paper of the two-sided tape.

Remove the Release Paper on the back, close and attach it.

Push and bend

Attach it to HDD closely not to loosen.

CAUTION S1:Insulation S2:Bitten S3:Sharp Edge S4:Part No. Check S5:Other

* Notes:

1. Apply the load when attaching the parts. 20N to 30N (2 to 3Kgf)/cm²

When attaching HDD Cushion (Yellow) and HDD Cushion (Black), set the bending part of the metal plate up.

HDD Thermal Plate

Do not bend it at a sharp angle to put natural R.

To the level of attaching closely in this range (15)

1-3 0-1 1-3 1-2 1-3

Longer Direction

Attach the HDD Cushion (Yellow)

HDD Cushion (Black)

Metal Plate

Attach the HDD Cushion (Black)

Attach the HDD Cushion (Yellow)

Attach the HDD Thermal Plate

Sheet

« Prepare the metal plate bend. »

0-1

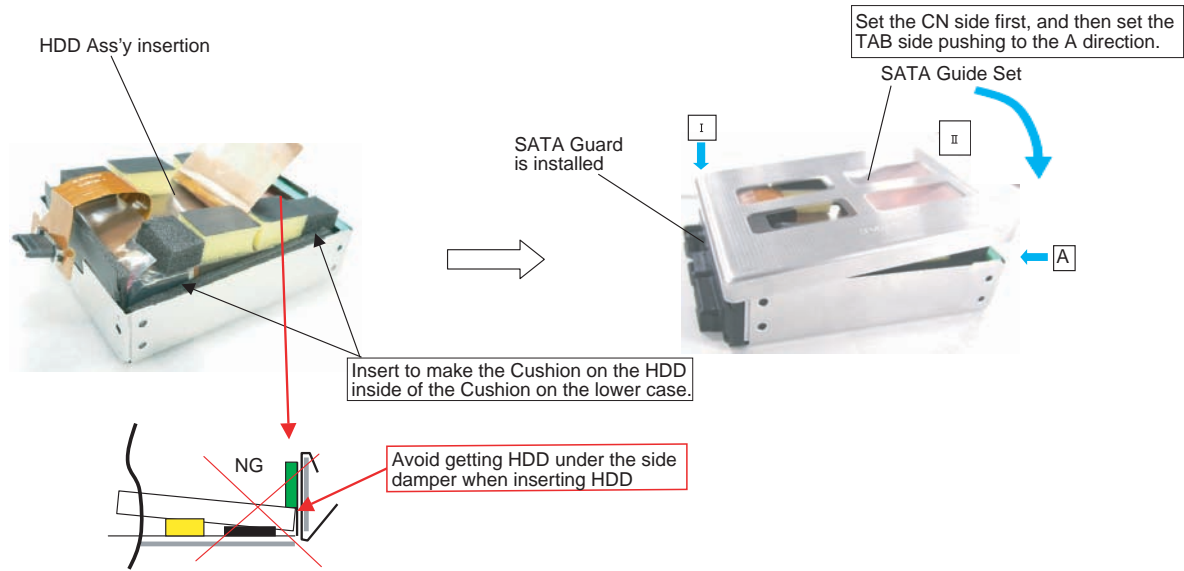

* Notes:
 1. Apply the load when attaching the parts. 20N to 30N (2 to 3Kgf)/cm²

Order of fixing
 Screw ① → Screw ② → Screw ③ → Screw ④

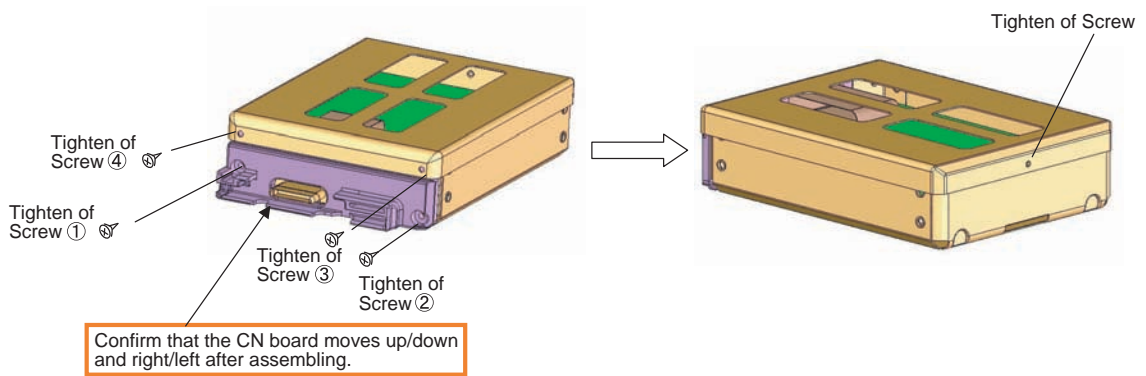

9.2.19. Setting the Battery Pack and HDD Pack

- 1. Set the HDD Pack.
- 2. Set the Battery Pack.

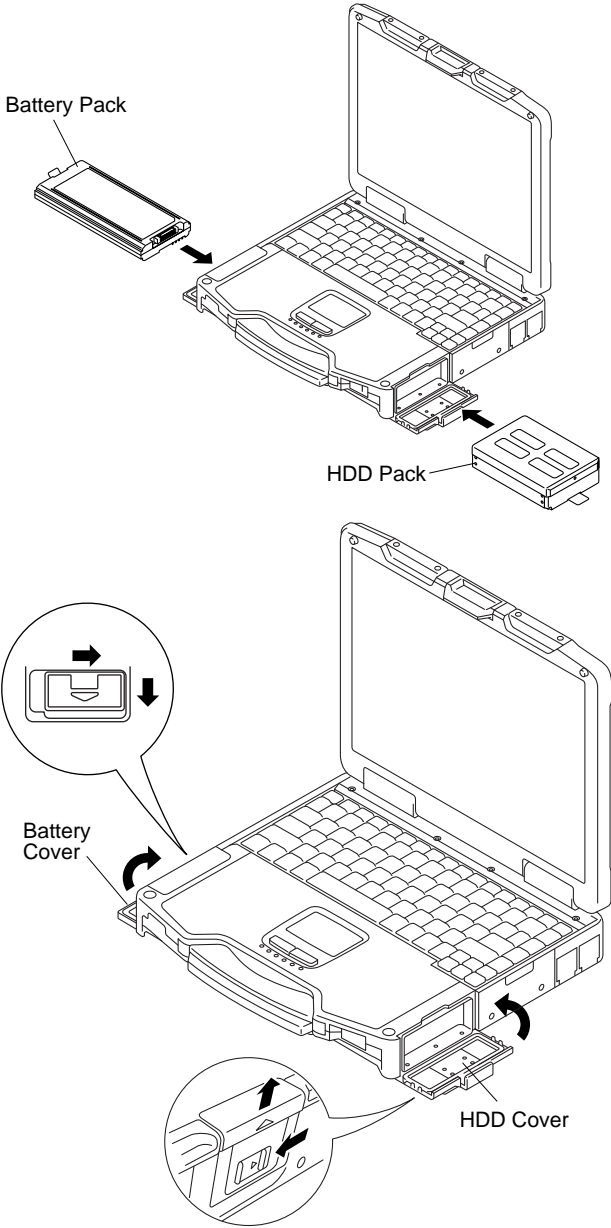

10 Exploded View

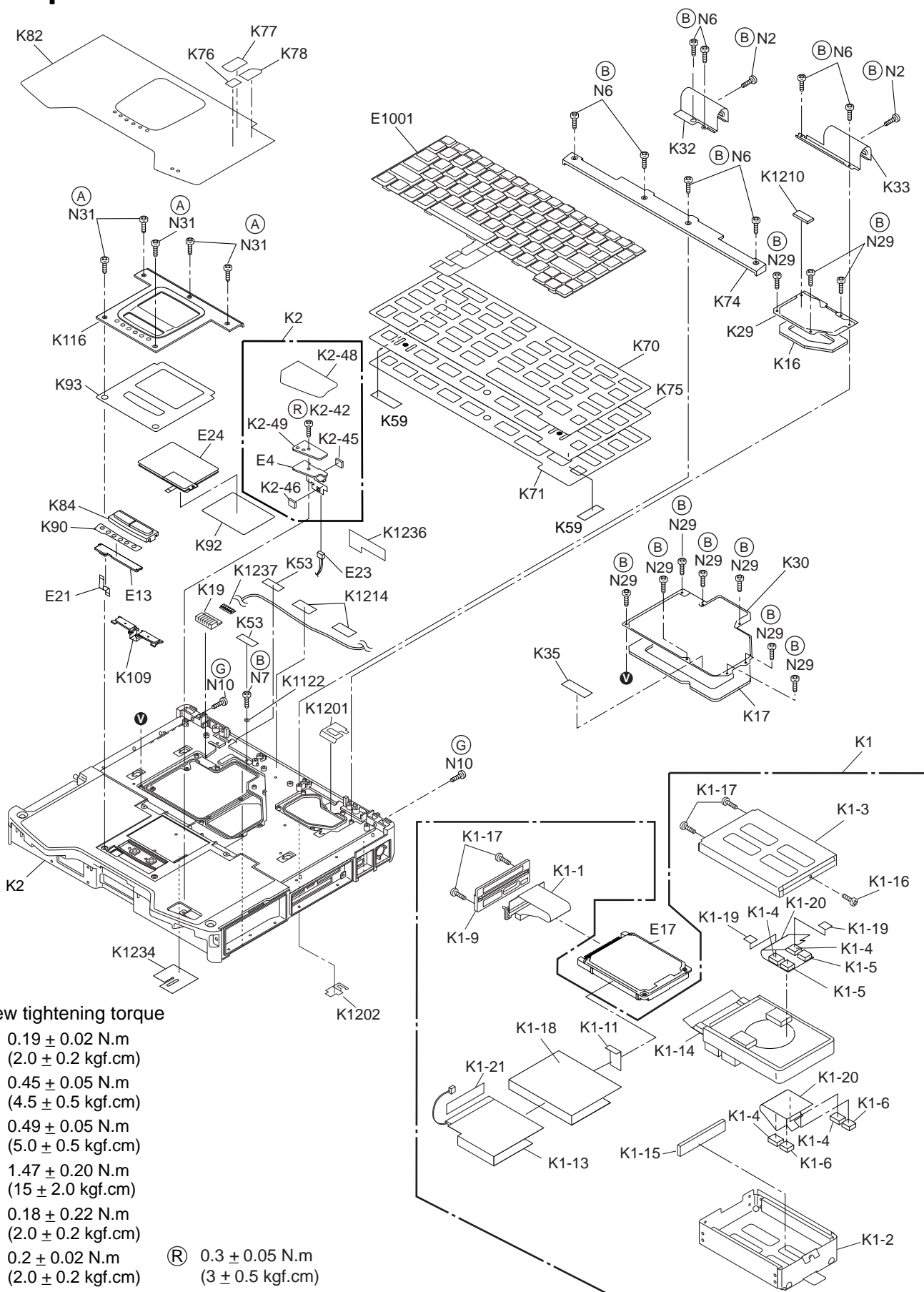

Screw tightening torque

- Ⓐ 0.19 ± 0.02 N.m
(2.0 ± 0.2 kgf.cm)
- Ⓑ 0.45 ± 0.05 N.m
(4.5 ± 0.5 kgf.cm)
- Ⓕ 0.49 ± 0.05 N.m
(5.0 ± 0.5 kgf.cm)
- Ⓖ 1.47 ± 0.20 N.m
(15 ± 2.0 kgf.cm)
- Ⓘ 0.18 ± 0.22 N.m
(2.0 ± 0.2 kgf.cm)
- Ⓛ 0.2 ± 0.02 N.m
- Ⓡ 0.3 ± 0.05 N.m
(3 ± 0.5 kgf.cm)

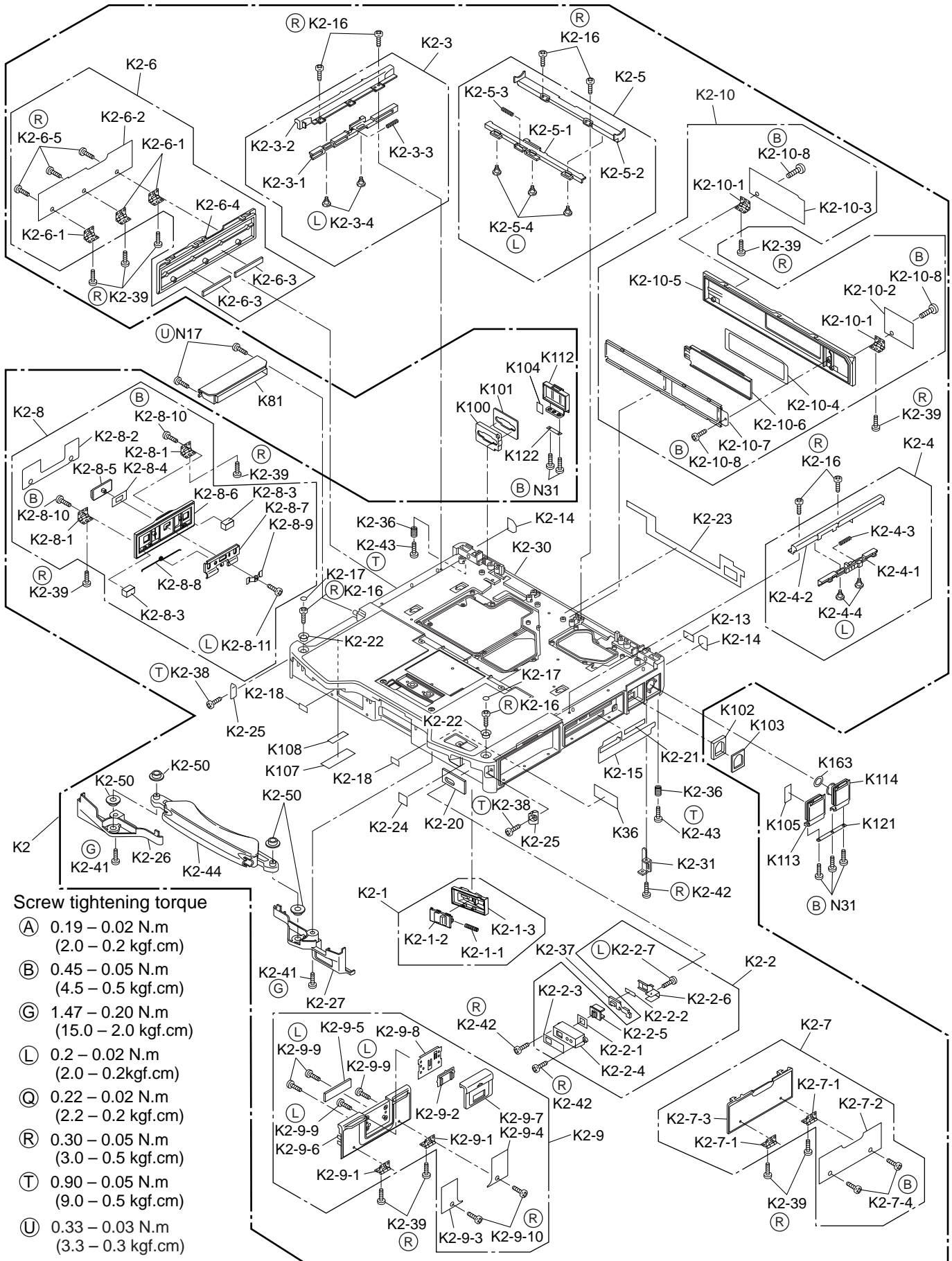

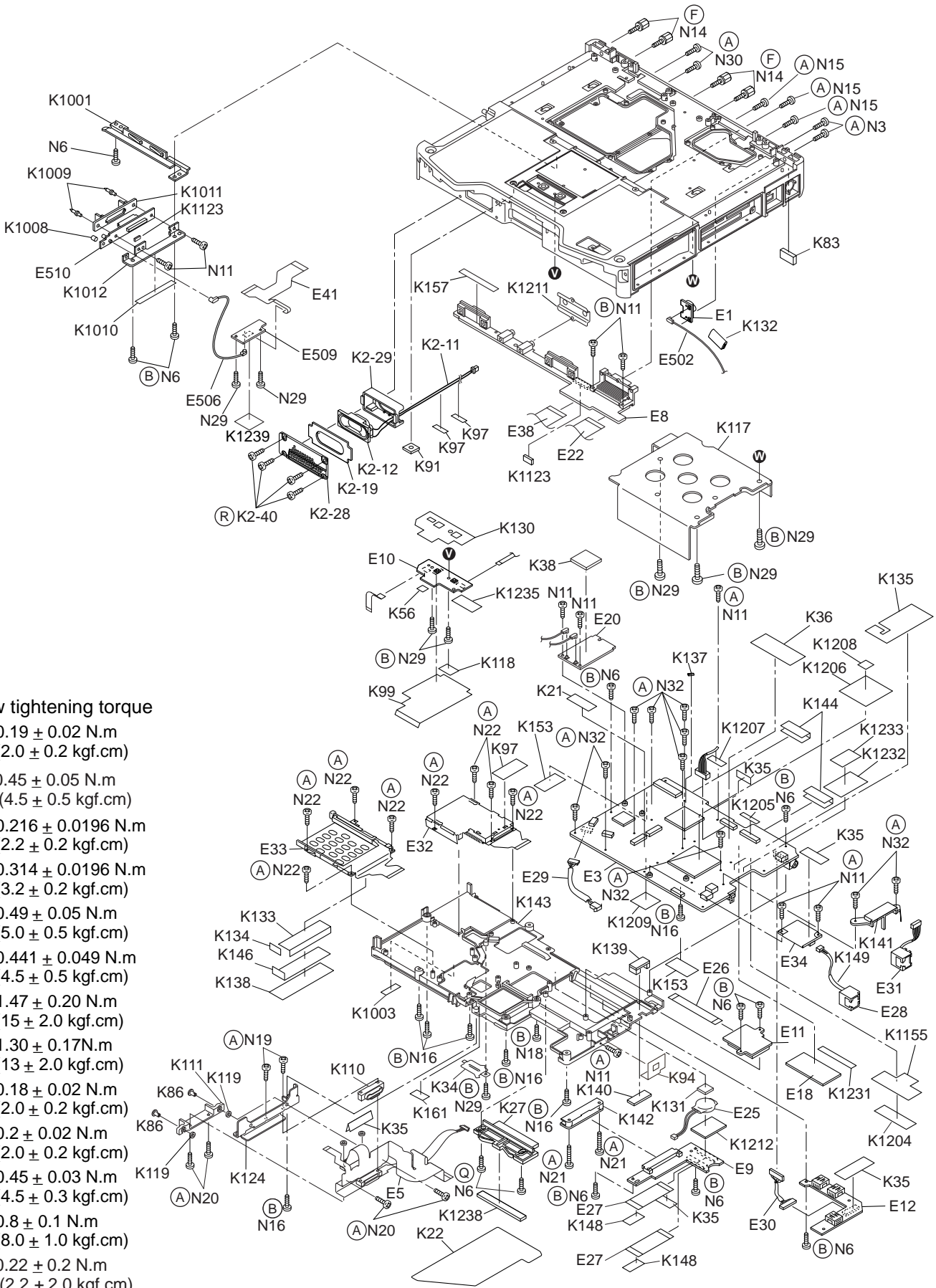

Screw tightening torque

- (A) $0.19 \pm 0.02 \text{ N.m}$
($2.0 \pm 0.2 \text{ kgf.cm}$)
- (B) $0.45 \pm 0.05 \text{ N.m}$
($4.5 \pm 0.5 \text{ kgf.cm}$)
- (C) $0.216 \pm 0.0196 \text{ N.m}$
($2.2 \pm 0.2 \text{ kgf.cm}$)
- (E) $0.314 \pm 0.0196 \text{ N.m}$
($3.2 \pm 0.2 \text{ kgf.cm}$)
- (F) $0.49 \pm 0.05 \text{ N.m}$
($5.0 \pm 0.5 \text{ kgf.cm}$)
- (G) $0.441 \pm 0.049 \text{ N.m}$
($4.5 \pm 0.5 \text{ kgf.cm}$)
- (H) $1.47 \pm 0.20 \text{ N.m}$
($15 \pm 2.0 \text{ kgf.cm}$)
- (I) $1.30 \pm 0.17 \text{ N.m}$
($13 \pm 2.0 \text{ kgf.cm}$)
- (L) $0.18 \pm 0.02 \text{ N.m}$
($2.0 \pm 0.2 \text{ kgf.cm}$)
- (M) $0.2 \pm 0.02 \text{ N.m}$
($2.0 \pm 0.2 \text{ kgf.cm}$)
- (N) $0.45 \pm 0.03 \text{ N.m}$
($4.5 \pm 0.3 \text{ kgf.cm}$)
- (P) $0.8 \pm 0.1 \text{ N.m}$
($8.0 \pm 1.0 \text{ kgf.cm}$)
- (Q) $0.22 \pm 0.2 \text{ N.m}$
($2.2 \pm 2.0 \text{ kgf.cm}$)

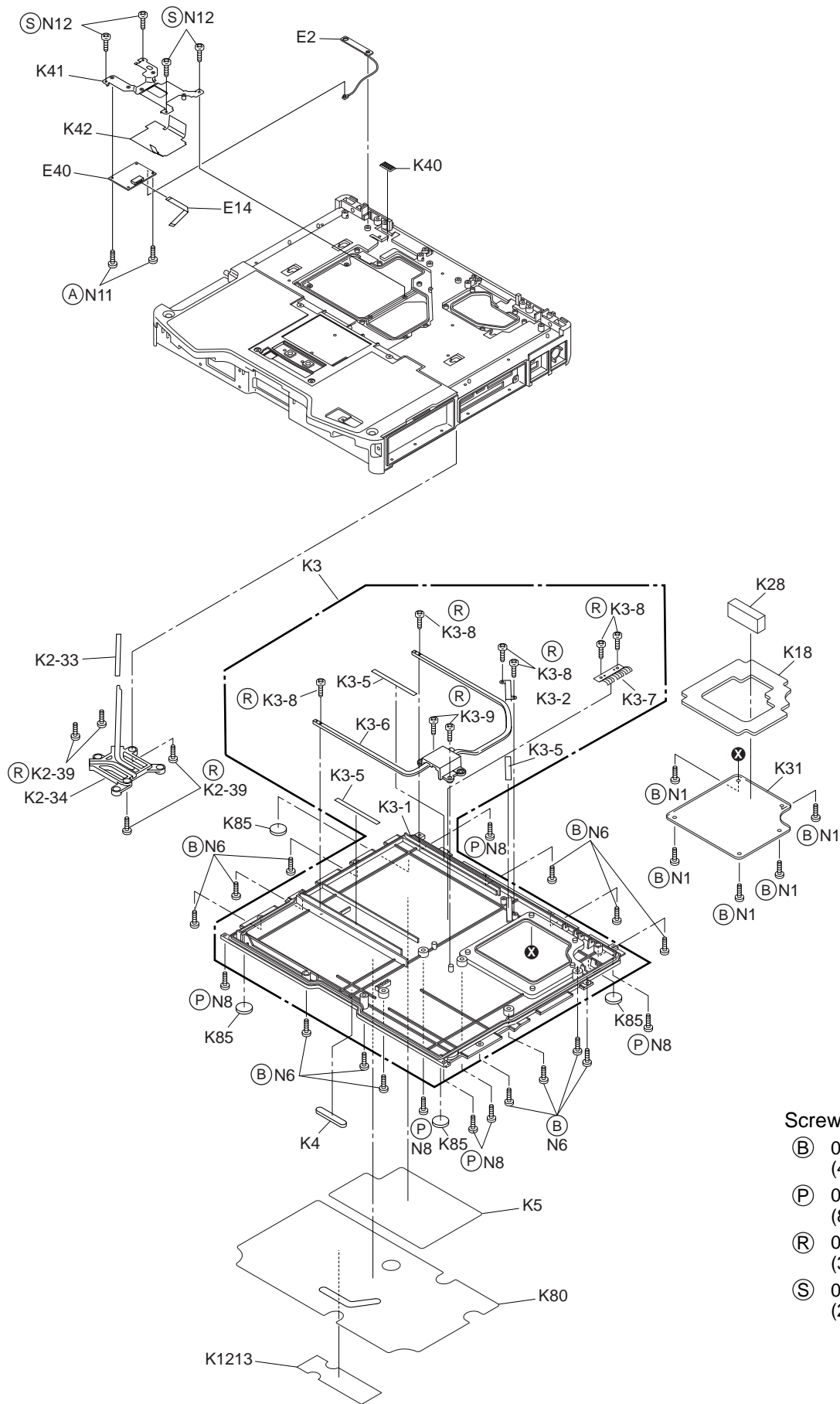

Screw tightening torque

- ⓑ 0.45 ± 0.05 N.m
(4.5 ± 0.5 kgf.cm)
- Ⓟ 0.8 ± 0.1N.m
(8.0 ± 1.0 kgf.cm)
- Ⓡ 0.3 ± 0.05 N.m
(3.0 ± 0.5 kgf.cm)
- Ⓢ 0.19 ± 0.05 N.m
(2.0 ± 0.5 kgf.cm)

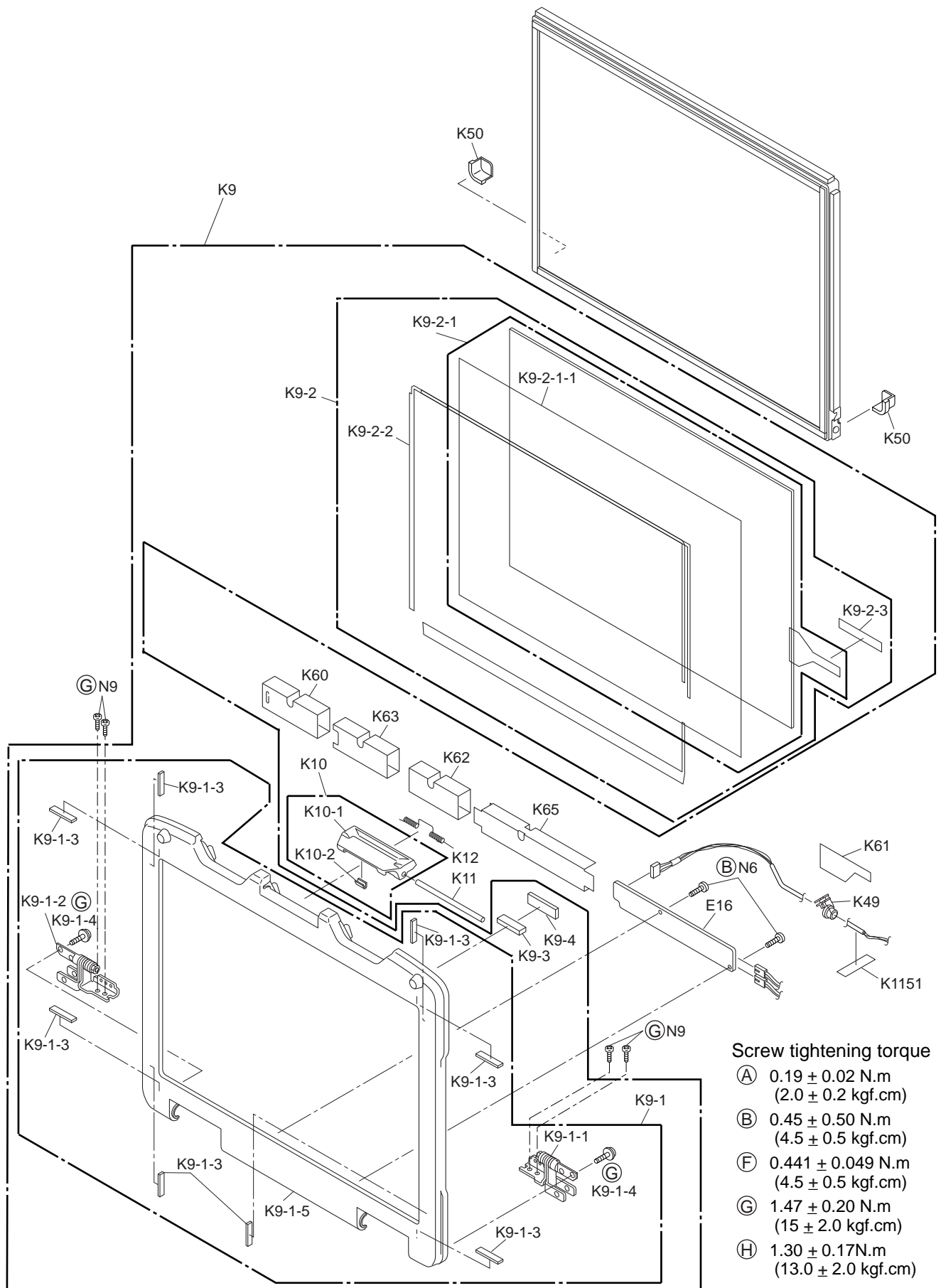

Screw tightening torque

- Ⓐ $0.19 \pm 0.02 \text{ N.m}$
($2.0 \pm 0.2 \text{ kgf.cm}$)
- Ⓑ $0.45 \pm 0.50 \text{ N.m}$
($4.5 \pm 0.5 \text{ kgf.cm}$)
- Ⓕ $0.441 \pm 0.049 \text{ N.m}$
($4.5 \pm 0.5 \text{ kgf.cm}$)
- Ⓖ $1.47 \pm 0.20 \text{ N.m}$
($15 \pm 2.0 \text{ kgf.cm}$)
- Ⓗ $1.30 \pm 0.17 \text{ N.m}$
($13.0 \pm 2.0 \text{ kgf.cm}$)

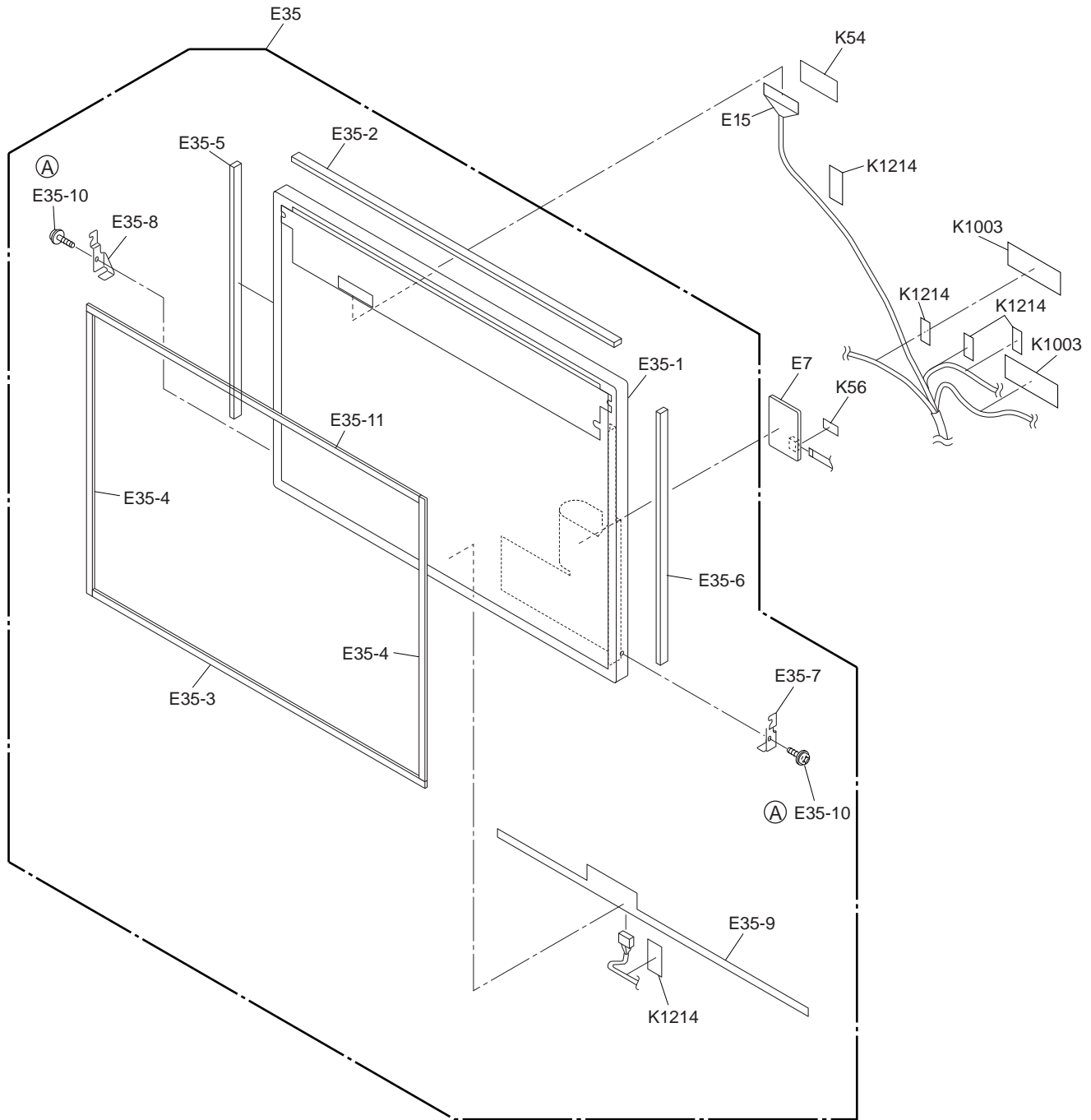

Screw tightening torque

- Ⓐ 0.19 ± 0.02 N.m
(2.0 ± 0.2 kgf.cm)
- Ⓑ 0.45 ± 0.05 N.m
(4.5 ± 0.5 kgf.cm)
- Ⓒ 0.216 ± 0.0196 N.m
(2.2 ± 0.2 kgf.cm)
- Ⓓ 0.314 ± 0.0196 N.m
(3.2 ± 0.2 kgf.cm)
- Ⓔ 0.49 ± 0.05 N.m
(5.0 ± 0.5 kgf.cm)

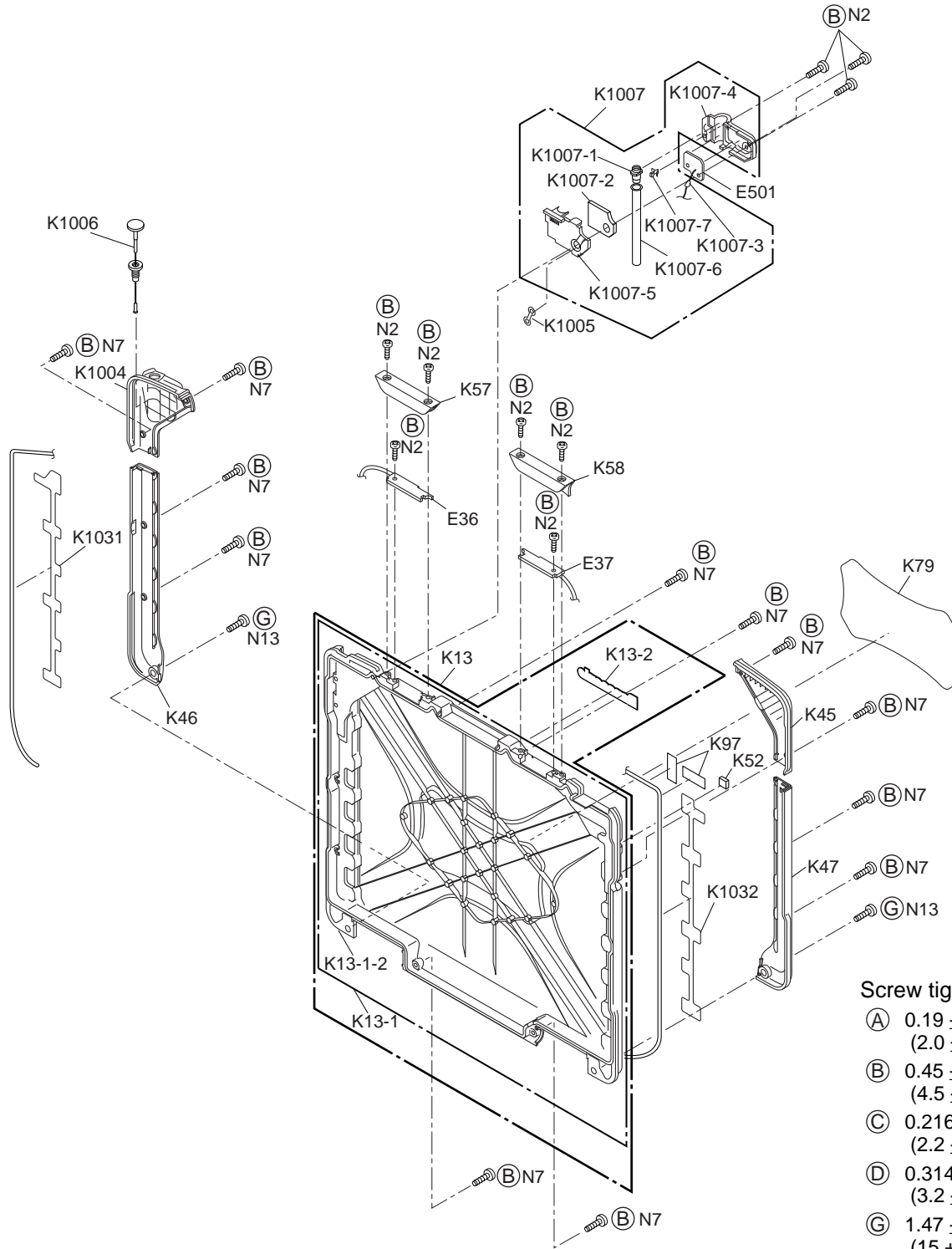

Screw tightening torque





- Ⓐ 0.19 ± 0.02 N.m
(2.0 ± 0.2 kgf.cm)
- Ⓑ 0.45 ± 0.05 N.m
(4.5 ± 0.5 kgf.cm)
- Ⓒ 0.216 ± 0.0196 N.m
(2.2 ± 0.2 kgf.cm)
- Ⓓ 0.314 ± 0.0196 N.m
(3.2 ± 0.2 kgf.cm)
- Ⓔ 1.47 ± 0.20 N.m
(15 ± 2.0 kgf.cm)
- Ⓞ 0.49 ± 0.05 N.m
(5.0 ± 0.5 kgf.cm)

Replacement Parts List

Note : Important Safety Notice

Components identified by  mark have special characteristics important for safety. When replacing any of these components, use only manufacturer's specified parts.

CF-30KTPAXxM

REF. NO and AREA	PART NO.	DESCRIPTION	Q'TY
Main Block Unit			
E1	DL3UP1336BAA	PCB, EXT ANT	RTL 1
E2	DL3UP1354CAA	PCB, BT ANT UNIT	RTL 1
E3	DL3UP1702AAA	MAIN PWB	1
E4	DFWP0150ZA	SW-LED FPC UNIT	1
E5	DL3UP1543AAA	HDD BATTERY FPC UNIT	1
E7	DL3UP1580AAA	PCB, TOUCH PANEL CONTROLLER	RTL 1
E8	DL3U11540DAA	PCB, IO	RTL 1
E9	DL3U21540DAA	PCB, MP	RTL 1
E10	DL3U31540DAA	PCB, PAD	RTL 1
E11	DL3U41540DAA	PCB, SD	RTL 1
E12	DL3U61540DAA	PCB, USB	RTL 1
E13	DL3U71540DAA	PCB, LED	RTL 1
E14	DFJK10U050BB	FFC	1
E15	DFJS1031WA	LCD CABLE	1
E16	 N0GF2J000003	INVERTER	1
E17	 N3CAYYY00048	HDD, 160GB 5400RPM SATA	1
E18	N5ZZ00000168	SO-DIMM, DDR2-667 2GB	1
E20	 N5HZC0000042	WIRELESS LAN MODULE	1
E21	DFJK10T017BB	FFC	1
E22	DFJK40T030BB	FFC IO40	1
E23	DFJS1037ZB	POWER CABLE	1
E24	N2EABEC00006	TOUCHPAD	1
E25	BR-2330A/SF	LITHIUM METAL PRIMARY BATTERY	1
E26	DFJK12U050BB	FFC SD	1
E27	DFJK40U056BB	FFC MP OUTER	2
E28	DFJS1032YA	MODEM CABLE	1
E29	DFJS1035YA	SATA CABLE	1
E30	DFJS1036ZA	CABLE USB	1
E31	DFJS1046YB	LAN CABLE	1
E32	K1NA26Z00001	CONNECTOR	1
E33	K1NA68Z00009	PCMCIA CONNECTOR	1
E34	 N5HAZ0000016	MODEM	1
E35	DFWV08A0123	LCD UNIT ASS'Y	1
E35-1	DL3DE0189AAA	LCD PREPARATION UNIT	1
E35-2	DFHG1926XA	LCD SIDE DAMPER(U)	1
E35-3	DFHG1927XA	TS SPACER(L)	1
E35-4	DFHG1928XA	TS SPACER(S)	2
E35-5	DFHG1882YA	LCD DMP L	1
E35-6	DFHG1883WA	LCD SIDE DMP R	1
E35-7	DFMD3130ZA	LCD HOLD PLATE L	1
E35-8	DFMD3131ZA	LCD HOLD PLATE R	1
E35-9	 L9DZYY000006	HEATER(LCD)	1
E35-10	DXYN2+C3FNL	SCREW	2
E35-11	DFHG2175ZA	TS SPACER L UPPER	1
E36	N1ZYYY000005	WLAN MAIN ANTENNA	1
E37	N1ZYYY000006	WLAN SUB ANTENNA	1
E38	DFUP1565ZA	FPC	1
E40	DL3U51540DAA	PCB, BT	RTL 1
E41	DFUP1717ZA	FPC	1
E501	DL3UP1535BAA	WAN ANTENNA FPC UNIT	1
E502	DFJS1055YA	CABLE	1
E506	DFJS1054ZA	CABLE	1
E509	DL3U11554AAA	PCB, ANT SW	RTL 1

E510		DL3U21554AAA	PCB, DOCKING	RTL	1
E1001		N2ABZY000035	KEYBOARD VISTA, U.S.		1
Accessories					
A1	△	NCR-B/901D	LITHIUM ION STORAGE BATTERY		1
A2	△	CF-AA1653ASC	AC ADAPTOR		1
A3		DFHR6207ZA	PEN		1
A4		DFHS2059ZA	TOUCH PANEL CLOTH		1
A5		DFME0148YA	PEN TETHER		1
A6	△	DFQW5231ZA	MANUAL		1
A7	△	K2CG3DR00003	AC CORD		1
A8		DFJS954ZA	MODEM CABLE		1
A21		DFHR6339ZA-0	DUMMY EXPRESS CARD		1
A22		DFHR6340ZA-0	DUMMY PC CARD		1
A23	△	DFKE0911ZC-0	MP DUMMY CASE		1
A91		DFQM8450MA	RECOVERY DVD, VISTA		1
Packing Material					
P1		DFPH0064ZA	PACKING PAPER		1
P2		DFPP0143ZA	PROTECTION BAG		1
P3		DFPE0852ZA	MANUAL HOLDER		1
P4		DFPN0845YA	DB CUSHION		1
P5		DFPK1202WAP	PACKING CASE(OVERSEAS)		1
Mechanical Parts					
K1		DFWV99A0133	HDD MOUNTING KIT		1
K1-1		DL3UP1557BAA	HDD PACK FPC UNIT		1
K1-2		DFMD8041YA	HDD LOWER CASE ASS'Y		1
K1-3		DFMD8042YA	HDD UPPER CASE ASS'Y		1
K1-4		DFHG1750YC	HDD CUSHION(YELLOW)		4
K1-5		DFHG1933ZA	FIX CORE CUSHION		2
K1-6		DFHG1934ZA	HDD FORMING M2		2
K1-9		DFHR6264ZA	SATA GUARD		1
K1-11		DFMX0634ZA	CD EDGE SHEET	NRP	1
K1-13	△	L9DZYY000010	HEATER(HDD)		1
K1-14		DFHR8522XB	HDD DAMPER ASS'Y		1
K1-15		DFHR8523WA	HDD SIDE DAMPER ASS'Y		1
K1-16		DFHE5025XA	SCREW		1
K1-17		DRQT2+E8FKL	SCREW		4
K1-18		DFMX1265ZB	HEATER INS SHEET		1
K1-19		DFHR3H11ZB	HDD CUSHION TOP SHEET		2
K1-20		DFMY3263ZA	HDD THERMAL PLATE LOWER		2
K1-21		DFHR7900ZA	PET TAPE		1
K2	△	DFKM8203ZA-0	TOP CASE ASS'Y MK3		1
K2-1		DFBD9010ZA-0	POWER SW ASS'Y		1
K2-1-1		DFHR6251ZA-0	POWER SW FLAME		1
K2-1-2		DFHR6252ZA-0	POWER SW KNOB		1
K2-1-3		DFUQ0114ZA	POWER SW KNOB SPRING		1
K2-2		DFBD9011XA-0	WIRELESS OFF SW ASS'Y		1
K2-2-1		DFHG1885YA	WM SW CUSHION		1
K2-2-2		DFHP7140ZAT	DOUBLE SIDE TAPE		1
K2-2-3		DFHR3D54ZA-0	WM SW SHEET		1
K2-2-4		DFHR6257ZB	WIRELESS SW CASE		1
K2-2-5		DFHR6258ZA-0	WIRELESS SW KNOB		1
K2-2-6		DFMD7B10YA	WM OFF SW PLATE		1
K2-2-7		XTB2+4GFN	SCREW		1
K2-3	△	DFKE8185ZA-0	MP LATCH ASS'Y		1
K2-3-1		DFBD0190ZA-0	MP LATCH LEVER		1
K2-3-2	△	DFKE0861ZA-0	MP LATCH CASE		1
K2-3-3		DFUQ0113ZA	SD LATCH SPRING		1
K2-3-4		DRHM0110ZAT	SCREW		2
K2-4	△	DFKE8186ZA-0	SD LATCH ASS'Y		1
K2-4-1		DFBD0192ZA-0	SD LATCH LEVER		1
K2-4-2	△	DFKE0867ZA-0	SD LATCH CASE		1
K2-4-3		DFUQ0113ZA	SD LATCH SPRING		1
K2-4-4		DRHM0110ZAT	SCREW		2
K2-5	△	DFKE8187YA-0	CN LATCH ASS'Y		1

K2-5-1		DFBD0193ZA-0	CN LATCH LEVER	1
K2-5-2	△	DFKE0869YA-0	CN LATCH CASE	1
K2-5-3		DFUQ0116ZA	CN LATCH SPRING	1
K2-5-4		DRHM0110ZAT	SCREW	3
K2-6	△	DFKE8188ZA-0	MP COVER ASS'Y	1
K2-6-1		DFBH3051ZA	LID HINGE	3
K2-6-2		DFGE0139ZA-0	MP COVER SHEET	1
K2-6-3		DFHR3E55ZA	MP COVER CUSHON	2
K2-6-4	△	DFKE0860ZA-0	MP COVER	1
K2-6-5		DRQT26+D3KLT	SCREW	3
K2-7	△	DFKE8189YA-0	SD COVER ASS'Y SDHC	1
K2-7-1		DFBH3051ZA	LID HINGE	2
K2-7-2		DFGE0140YA-0	SD COVER SHEET	1
K2-7-3	△	DFKE0866ZA-0	SD COVER	1
K2-7-4		DRQT26+D3KLT	SCREW	2
K2-8	△	DFKE8190XB-0	BATT COVER ASS'Y	1
K2-8-1		DFBH3051ZA	LID HINGE	2
K2-8-2		DFGE0141ZA-0	BATT COVER SHEET	1
K2-8-3		DFHR3E56ZA	BATT COVER CUSHION	2
K2-8-4		DFHR3E59ZA	BATT LID KNOB SHEET	1
K2-8-5	△	DFKE0799ZA-0	LID KNOB	1
K2-8-6	△	DFKE0862XA-0	BATT COVER	1
K2-8-7		DFMD7B12ZA	BATT LATCH ANGLE	1
K2-8-8		DFUN0084XA	BATT LATCH SPRING	1
K2-8-9		DFUS0323ZA	LID KNOB SPRING PLATE	1
K2-8-10		DRQT26+D3KLT	SCREW	2
K2-8-11		DXQT2+F3FNLT	SCREW	1
K2-9	△	DFKE8191YA-0	HDD COVER ASS'Y	1
K2-9-1		DFBH3051ZA	LID HINGE	2
K2-9-2		DFBD0191ZA-0	HDD COVER LOCK KNOB	1
K2-9-3		DFGE0149ZA-0	HDD COVER SHEET L	1
K2-9-4		DFGE0150ZA-0	HDD COVER SHEET R	1
K2-9-5		DFHR3E57ZA	HDD COVER CUSHION	1
K2-9-6	△	DFKE0864YA-0	HDD COVER	1
K2-9-7	△	DFKE0865ZA-0	HDD COVER LID KNOB	1
K2-9-8		DFUS0311ZA	HDD COVER SPRING PLATE	1
K2-9-9		DRQT2+D25KMT	SCREW	4
K2-9-10		DRQT26+D3KLT	SCREW	2
K2-10	△	DFKE8192ZB-0	CN COVER ASS'Y	1
K2-10-1		DFBH3051ZA	LID HINGE	2
K2-10-2		DFGE0143ZB-0	CN COVER SHEET L	1
K2-10-3		DFGE0144ZB-0	CN COVER SHEET R	1
K2-10-4		DFHR3E58ZA	CN PACKIN-SLIDE	1
K2-10-5	△	DFKE0868ZA-0	CN COVER	1
K2-10-6	△	DFKE0875ZA-0	CN SLIDE COVER	1
K2-10-7		DFMD7B11ZA	CN WATER PROOF PLATE	1
K2-10-8		DRQT26+D3KLT	SCREW	3
K2-11		DFJS1030ZA	SP CABLE	1
K2-12		LOAA04C00012	SPEAKER	1
K2-13		DFGE0111YA-0	TOP LOOK SHEET	1
K2-14		DFGE0145ZA-0	REAR BELT COVER SHEET	2
K2-15		DFGL0153ZB-0	SD LED SHEET (NO SC)	1
K2-16		DFHE5121YA	SCREW	8
K2-17		DFHG1699ZA	LCD LOCK SHEET	2
K2-18		DFHG1891ZA	HANDLE ARM CUSHION	2
K2-19		DFHG1892YA	SPEAKER CASE CUSHION	1
K2-20		DFHG1931ZA	WM SW CASE CUSHION	1
K2-21		DFHG1973ZAT	SD SHEET SPACER TW	1
K2-22		DFHM0419YA	LCD FOOT CAP	2
K2-23		DFHR3D56ZA-0	CN COVER SHEET	1
K2-24		DFHR3E66ZA	POWER SW CUSHION	1
K2-25		DFHR6291YB-0	FRONT BELT COVER	2
K2-26	△	DFKE0947ZA-0	HANDLE BASE L 2ND	1
K2-27	△	DFKE0948ZA-0	HANDLE BASE R 2ND	1

K2-28	△	DFKE0856ZB-0	SPEAKER CASE A		1
K2-29	△	DFKE0876ZB	SPEAKER CASE B		1
K2-30	△	DFKM0555ZA-0	TOP CASE (2ND)		1
K2-31		DFMD2170ZA	KENSINGTON PLATE		1
K2-33		DFMY0414ZA	CPU HEAT PIPE RUBBER		1
K2-34		DFMY5049ZA	HEAT PIPE UNIT E		1
K2-36		DFUQ0102ZA	POTRE SPRING		2
K2-37		DFWP0145YA	FPC		1
K2-38		DRHM0118ZAT	SCREW		2
K2-39		DRQT26+D3KLT	SCREW		15
K2-40		DRQT26+D5KLT	SCREW		4
K2-41		DRSN4+6FKLT	SCREW		2
K2-42		DXQT26+D4NLT	TW SCREW		4
K2-43		DXQT3+F4FNLT	SCREW		2
K2-44		DFKH8009YA-0	HANDLE ASS'Y		1
K2-45		DFHP7140ZAT	DOUBLE SIDE TAPE		1
K2-46		DFHR3G74ZAT	PW SW CUSHION		1
K2-48		DFHR3E97ZA	P LED SHEET		1
K2-49		DFHR6356ZA	POWER SW LED PANEL TW		1
K2-50		DFHR6089YA-0	HANDLE ARM BUSH		4
K3	△	DFKF8177ZA-0	BOTTOM CASE ASS'Y MK3		1
K3-1	△	DFKF0295ZA-0	BOTTOM CASE (2ND)		1
K3-2		DFMD2172ZA	HEAT PIPE ANGLE A		1
K3-5		DFMY0437ZA	HEAT PIPE RUBBER B		3
K3-6		DFMY5048ZA	HEAT SINK		1
K3-7		DFUS0324ZA	MP ESD SPRING		1
K3-8		DRQT26+D3KLT	SCREW		6
K3-9		DXQT26+D4NLT	TW SCREW		2
K4		DFGE0087ZA-0	BOTTOM COVER SHEET D	NRP	1
K5		DFGE0138ZB	BOTTOM CASE SHEET		1
K9		DFWV80A0463	LCD FRONT CABINET/TS PANEL ASS'Y		1
K9-1	△	DFKF8176ZA-0	LCD FRONT ASS'Y (2ND)		1
K9-1-1		DFBH1180ZB	HINGE ASS'Y R		1
K9-1-2		DFBH1181ZB	HINGE ASS'Y L		1
K9-1-3		DFHR3E61YA	TS DUMPER PC		8
K9-1-4		DRYN4+J10KLT	SCREW		2
K9-1-5	△	DFKF0296ZA-0	LCD FRONT (2ND)		1
K9-2		DFWV84A0337	TOUCH SCREEN PANEL KIT		1
K9-2-1		DL3DV0189AAA	TS PREPARATION UNIT		1
K9-2-1-1		DFHR3L78ZA	PROTECTIVE FILM		1
K9-2-2		DFHP7246ZB	TS FIXED TAPE	NRP	1
K9-2-3		DFHR3695ZA	TS FPC SPACER		1
K9-3		DFHE0843ZA	LCD MAGNET		1
K9-4		DFHG1929ZA	MAGNET CUSHION		1
K10		DFBS8003ZA-0	LCD LATCH ASS'Y		1
K10-1		DFBS0073ZA-0	LCD LATCH		1
K10-2		DFHR6313ZA	LCD LATCH SLIDER		1
K11		DFDF5024ZA	LCD LATCH SHAFT		1
K12		DFUN0083ZA	LCD LATCH SPRING		1
K13		DFWV80C0549	LCD REAR CABINET ASS'Y		1
K13-1	△	DFKM8202ZA-0	LCD REAR ASS'Y (2ND)		1
K13-2		DFGB0131YA-0	PANASONIC BADGE		1
K16		DFHG1886ZA	LCD CABLE COVER CUSHION	NRP	1
K17		DFHG1887ZA	KBD CABLE COVER CUSHION	NRP	1
K18		DFHG1888ZB	DIMM COVER CUSHION	NRP	1
K19		DFHG1890ZA	ANT CABLE CUSHION	NRP	1
K21		DFHR3E98ZA	KB WP SHEET	NRP	1
K22		DFHR3E99ZA	ANT CABLE SHEET		1
K27		DFHR6270YA	DIMM STOPPER BASE		1
K28		DFHR6296ZA	DIMM COVER SPACER		1
K29	△	DFKE0857ZA-0	LCD CABLE COVER		1
K30	△	DFKE0858YC-0	KB CABLE COVER		1
K31	△	DFKE0859ZB-0	DIMM COVER		1

K32	△	DFKE0873ZB-0	HINGE COVER L		1
K33	△	DFKE0874ZB-0	HINGE COVER R		1
K34		DFMD2177ZA	ANTENNA CABLE PLATE		1
K35		DFMX0634ZA	CD EDGE SHEET		6
K36		DFMX0999ZA	RJ11 CABLE FIX SHEET	NRP	2
K38		DFMY0438ZA	W-LAN HEAT RUBBER	NRP	1
K41		DFMD7B13ZA	GPS BT ANGLE		1
K42		DFMX1260YA	GPS INS SHEET A	NRP	1
K45		DFGX0458ZC-0	LCD CONER COVER R		1
K46		DFGX0459ZB-0	LCD CONER SIDE COVER L		1
K47		DFGX0460ZB-0	LCD CONER SIDE COVER R		1
K49		DFHG1881ZA	LCD CABLE BUSH		1
K50		DFHG1884YA	LCD DROP HOLDER		2
K52		DFHG1942ZA	REAR SCREW SHEET	NRP	1
K53		DFHR3159ZA	TOP CASE SHEET		2
K54		DFHR3F07XA	LCD CABLE WP SHEET		1
K56		DFHR7968ZA	CDD SHEET	NRP	2
K57	△	DFKE0871ZA-0	W-LAN ANT COVER L		1
K58	△	DFKE0872ZA-0	W-LAN ANT COVER R		1
K59		DFMC0685ZA	LCD CONDUCTIVE TAPE	NRP	2
K60		DFMC0863ZA	INV SHIELD CASE		1
K61		DFMC0873ZA	INV MIL SHIELD		1
K62		DFMC0874YA	INV SHEILD TAPE		1
K63		DFMC0876ZA	INV SHIELD CASE OUTSIDE		1
K65		DFMX1241ZB	INV CASE		1
K70		DFHP7261XA	KB SPACER TAPE		1
K71		DFHR3E65VA	KB SPACER SHEET		1
K74		DFHR6260ZB-0	KB COVER		1
K75		DFMD7B38ZB-0	KB BACK PLATE		1
K76		DFQT0045ZA	ENERGY STAR LABEL		1
K77		DFQT0066ZA	VISTA BASIC LABEL		1
K78		DFQT0076ZA	CENTRINO 2 DUO VPRO LABEL		1
K79		DFGB0165XA-0	TOUGH BADGE NEW		1
K80	△	DFGT1330ZA	RATING SHEET MK3 US		1
K81		DFGE0151ZA-0	WM COVER 30		1
K82		DFGP0201ZA-0	PALM TOP SHEET		1
K83		DFHE1037ZA	DC GASKET	NRP	1
K84		DFHG1901ZA-0	TOUCH PAD SW RUBBER		1
K85		DFHG370ZA	FOOT RUBBER	NRP	4
K86		DFHM0396ZA	BATT CN PIN		2
K90		DFHR3619ZA	LEDX6 SPACER SHEET		1
K91		DFHR3636ZA	CABLE HOLD SHEET	NRP	1
K92		DFHR3643ZA	TP BOTTOM TAPE		1
K93		DFHR3E67ZA	PAD WP SHEET		1
K94		DFHR3E93VA	1394 SHEET		1
K97		DFHR3F49ZA	CABLE TAPE 5X18	NRP	5
K99		DFHR3F87WA	PAD PROTCT SHEET	NRP	1
K100		DFHR3G02ZA	SERIAL COVER SPACER	NRP	1
K101		DFHR3G03ZA	SERIAL WP SHEET	NRP	1
K102		DFHR3G04ZA	USB COVER SPACER	NRP	1
K103		DFHR3G05ZA	USB WP SHEET	NRP	1
K104		DFHR3G09ZA	SERIAL INSIDE SPACER		1
K105		DFHR3G10ZA	USB INSIDE SPACER		1
K107		DFHR3G32ZA	BATTERY SLIDE SHEET		1
K108		DFHR3G41ZA	BATT CUSHION		1
K109		DFHR6355ZA	TP SW KNOB IN		1
K110		DFHR6246ZA	HDD GUIDE		1
K111		DFHR6247ZB	BATT GUIDE		1
K112		DFHR6253WA-0	SERIAL COVER		1
K113		DFHR6254VA-0	USB COVER		1
K114		DFHR6255VA-0	DC-IN COVER		1
K116		DFHR6259YC-0	PALM TOP COVER		1
K117		DFHR6295ZA	HDD CABLE COVER		1
K118		DFHR7953ZA	LAN SHEET	NRP	1

K119	DFHR8521ZA	BATT CN PIN CUSHION		2
K121	DFMD4066ZB-0	DC USB COVER PLATE		1
K122	DFMD4067ZB-0	SERIAL COVER PLATE		1
K124	DFMD7B00ZA	BATT HDD CN ANGLE		1
K130	DFMX1256ZA	TP INS SHEET		1
K131	DFHG1403YA-0	COIN BATTERY CUSHION		1
K132	DFHG1467ZA	LEAD SW CUSHION		1
K133	DFHP7275ZA	CN TAPE L	NRP	1
K134	DFHP7276ZA	CN TAPE S	NRP	1
K135	DFHR3E94ZA	DMD CABLE SHEET	NRP	1
K137	DFHR3N15ZA	PWB SPACER 3		1
K138	DFHR3G11ZA	CN SHEET	NRP	1
K139	DFHR3G47ZA	USB SCREW COVER		1
K140	DFHR3G48ZA	USB SCREW COVER B		1
K141	DFHR6261ZA	MODEM LAN CASE		1
K142	DFHR6272ZA	MP GUIDE		1
K143	△ DFKE0943ZA	MAIN CHASSIS 2ND		1
K144	DFMC0875ZA	MAIN CHASSIS SHIELD		2
K146	DFMD7B22ZA	CN PLATE		1
K148	DFMX0635ZB	FFC CN STOPPER		2
K149	DFMX0702ZA	FFC CN STOPPER PAD	NRP	1
K153	DFMX1280ZA	EXP FPC SHEET	NRP	2
K155	DFQT9745ZA	BOARD LABEL		2
K157	DFHR3F53ZA	IO PWB SHEET	NRP	1
K161	DFHP7118ZA	TAPE	NRP	1
K163	DFHR3G93ZA	DC-IN WP SHEET	NRP	1
K1001	DFMD9092ZA	FRAME GUIDE ANGLE ASM		1
K1003	DFMX1066ZA	ISO SHEET	NRP	3
K1004	DFGX0465ZB-0	W-ANT CORNER COVER		1
K1005	DFHR3E78ZA	WATERPROOF SHEET R	NRP	1
K1006	N1AA91000008	ANTENNA ELEMENT		1
K1007	DFWV39A0003	ANTENNA W-RDY KIT		1
K1007-1	DFDF5025ZA	W-ANT ROD ANT PLUG		1
K1007-2	DFHR3E79ZA	WATERPROOF SHEET 1	NRP	1
K1007-3	DFHR3E80ZA	WATERPROOF SHEET CABLE		1
K1007-4	DFHR6300ZA	W-ANT ROD HOLDER-L		1
K1007-5	DFHR6301ZA	W-ANT ROD HOLDER-U		1
K1007-6	DFHR6302ZA	W-ANT ROD ANT TUBE		1
K1007-7	DFMD7B15ZA	W-ANT SPRING PLATE		1
K1008	DFHD04E003YB	PLATE SHAFT B		1
K1009	DFHM0336YB	PLATE SHAFT A		2
K1010	DFHR3G23ZA	W-READY SHEET		1
K1011	DFHR6113YA	CN GUIDE		1
K1012	DFMD1169YA	CONNECTOR ANGLE		1
K1031	DFHR3H16ZA	REAR CABLE SHEET L	NRP	1
K1032	DFHR3H17ZA	REAR CABLE SHEET R	NRP	1
K1122	DFNW2701ZA	TOP WP WASHER		1
K1123	DFHR3741ZA	FFC CN STOPPER		2
K1151	DFMC0891ZA	LCD CABLE SHIELD TAPE	NRP	1
K1155	DFMY3257YA	2G DIMM HEAT PLATE	NRP	1
K1201	DFHR3K09ZA	LCD CABLE GUIDE		1
K1202	DFHR3H39YA	LCD CABLE CLAMP		1
K1204	DFHE0915ZA	EMI SHEET 10X20	NRP	1
K1205	DFHG830ZA	CON SPACER		1
K1206	DFMX1342ZA	MCH SHEET		1
K1207	DFHR3K18ZA	ANT CABLE WP SHEET		1
K1208	DFMY0472ZA	THERMAL RUBBER CPU	NRP	1
K1209	DFMY0508ZA	CPU HEAT RUBBER	NRP	1
K1210	DFHE1106ZA	KBD GASKET	NRP	1
K1211	DFHR6354ZA-0	MIC JACK HOLDER		1
K1212	DFHG2077ZA	COIN BATT CUSHION		1
K1213	DFQT0055XA	COA SERIAL LAMINATE		1
K1214	DFMX0383TA	INSULATION PARTS	NRP	6
K1231	DFHR3H09ZA	DIMM CUSHION MAIN		1

K1232	DFHR3N35ZA	BUSTERAID SHEET	NRP	1
K1233	DFMC0933ZA	BUSTERAID 24X15	NRP	1
K1234	DFHR3M10YA	TP FPC SHEET		1
K1235	DFHR3N21ZA	TPAD FPC SHEET	NRP	1
K1236	DFHR3N10ZA	P-CABLE CN TAPE	NRP	1
K1237	DFHR6446ZA	MINI CRAMP_5		1
K1238	DFHR3H10ZA	DIMM CUSHION STOPPER		1
K1239	DFMX0657ZA	LCD CABLE SHEET		1
N1	DRHM0002ZA	SCREW		5
N2	DRHM5054XA	SCREW		11
N3	DRQT2+G6FKL	SCREW		2
N6	DRQT26+E4FKL	SCREW		35
N7	DRSB26+10HKL	SCREW		13
N8	DRSB3+8FKL	SCREW		6
N9	DRYN4+J10FKL	SCREW		4
N10	DXSB4+15FNMB	SCREW		2
N11	DFHE5025XA	SCREW		12
N12	DXQT2+F3FNL	SCREW		4
N13	DRSB4+10FKL	SCREW		2
N14	DFHE5058ZB	SCREW		4
N15	DRHM5104ZA	SCREW		3
N16	DRQT26+E5FKL	SCREW		7
N17	DRQT26+E6FKL	SCREW		2
N18	DRSB26+8HKL	SCREW		1
N19	DRSN2+10FNL	SCREW		2
N20	DXQT2+D4FNL	SCREW		4
N21	DXQT2+E12FNL	SCREW		2
N22	DXQT2+G4FNL	SCREW		8
N29	DRQT26+E3FNL	SCREW		18
N30	DXHM0057ZA	SCREW		2
N31	DRQT26+E3FKL	SCREW		10
N32	DXSB26+4FNL	SCREW		10

Replacement Parts List

Note: Important Safety Notice

Components identified by  mark have special characteristics important for safety. When replacing any of these components use only manufacturer's specified parts.

CF-30KTPAXxM

REF. NO and AREA	PART NO.	DESCRIPTION	Q'TY
MAIN PCB			
C 1, 2, 3, 5, 6, 7, 10, 11, 12, 14, 15, 16, 18, 19, 20, 22, 23, 24, 27, 28, 29, 30, 31, 32, 44, 74, 79, 95, 98, 108, 122, 123, 130, 132, 134, 136, 144, 146, 148, 150, 174, 177, 182, 199, 214, 218, 219, 274, 275, 288, 373, 374, 394, 404, 417, 442, 528, 636, 649, 650, 691, 692, 722, 727, 788, 789, 799, 800, 810, 811, 812, 815, 823, 836, 839, 844, 846, 851, 857, 861, 872	F1J0J106A013	CAPACITOR, 6.3V, 10 μ F	83
C 4, 97, 100, 114, 512, 513, 514, 515, 552, 875,	EEFCX0D221R	CAPACITOR, 2V, 220 μ F	11
C 8, 9, 13, 17, 21, 25, 93, 208, 385, 632, 633, 634, 702, 780, 781, 782, 783, 784, 785, 883, 885, 904, 906, 908, 910, 913, 915, 924	F1H1A225A025	CAPACITOR, 10V, 2.2 μ F	28
C 26, 46, 47, 48, 50, 63, 65, 69, 70, 71, 76, 85, 101, 112, 125, 126, 127, 128, 131, 133, 135, 137, 139, 140, 141, 142, 145, 147, 149, 151, 170, 171, 173, 175, 176, 179, 185, 186, 187, 188, 192, 195, 196, 197, 207, 210, 247, 248, 249, 250, 276, 277, 278, 279, 281, 282, 289, 291, 295, 298, 302, 306, 317, 318, 319, 320, 326, 327, 328, 329, 330, 331, 332, 333, 334, 335, 336, 347, 392, 403, 407, 409, 411, 413, 414, 415, 416, 418, 419, 420, 433, 436, 437, 438, 441, 445, 448, 449, 451, 452, 461, 466, 474, 478, 479, 480, 481,	F1G1C104A042	CAPACITOR, 16V, 0.1 μ F	171

482, 485, 489, 490, 496, 531, 581, 665, 667, 673, 678, 693, 694, 700, 705, 718, 719, 721, 723, 728, 748, 749, 750, 751, 795, 803, 804, 805, 806, 807, 808, 809, 817, 820, 822, 824, 826, 827, 828, 837, 840, 841, 845, 847, 849, 850, 852, 856, 858, 859, 860, 862, 866, 867, 868, 869, 870, 873, 886, 892, 896, 921, 922, 926				
C 43, 487, 488		F1G1H100A544	CAPACITOR, 50V, 10pF	3
C 45, 91, 285, 453, 454, 455, 456, 457, 458, 459, 460, 462, 471, 473, 475, 493, 497, 498, 500, 540, 542, 544, 547, 561, 564, 568, 584, 625, 626, 627, 628, 630, 706, 707, 708, 818, 819, 821, 864		F1G1H102A496	CAPACITOR, 50V, 1000pF	39
C 51, 52, 53, 59, 67, 89		F1G0J474A001	CAPACITOR, 6.3V, 0.47μF	6
C 54, 57, 73, 78, 81, 172, 180, 181, 205, 358, 637, 715, 716, 717, 756, 757, 758, 759, 760, 761, 762, 763, 764, 765, 766, 767, 768, 769, 770, 771, 772, 773, 774, 775, 776, 777, 778, 779, 853, 854, 863, 871, 925, 932		F1G0J105A001	CAPACITOR, 6.3V, 1μF	44
C 56, 68, 83, 88, 90, 94, 111, 213, 613, 735, 738, 740, 745, 798, 829, 874, 877, 881, 900, 902		F1J0J2260004	CAPACITOR, 6.3V, 22μ	20
C 60, 61, 110, 113, 189, 190, 375, 383, 384		F1G0J224A001	CAPACITOR, 6.3V, 0.22μF	9
C 152, 153, 154, 155, 200, 201, 202, 203, 211, 215, 280, 299, 309, 313, 359, 397, 399, 400, 405, 406, 412, 422, 423, 435, 443, 468, 525, 557, 569, 574, 575, 579, 701, 703, 732, 733, 734, 737, 739, 744, 752, 753, 754, 755, 786, 880, 882, 884, 887, 888, 889, 890, 891, 893, 894, 895, 897, 898, 899, 901, 903, 905, 907, 909, 911, 912, 914, 916, 917, 918, 919, 920, 923		F1G1E103A062	CAPACITOR, 25V, 0.01μF	73
C 156, 157		F1G1H150A542	CAPACITOR, 50V, 15pF	2
C 162, 163, 164, 165, 166, 167, 168, 169, 353, 354, 355, 356, 357, 360, 363, 364, 371, 372, 376, 377, 395, 724, 729, 801, 802, 832, 833, 931		F1G1A104A014	CAPACITOR, 10V, 0.1μF	28
C 204		F1G1H7R0A544	CAPACITOR, 50V, 7.0pF	1
C 206		F1G1H6R0A544	CAPACITOR, 50V, 6.0pF	1

C 209, 270, 271, 272, 273, 284, 301, 305, 307, 352, 387, 389, 390, 393, 408, 477, 527, 603, 617, 618, 642, 714, 736, 742, 787, 790, 791, 814, 825, 933	F1H1A1050015	CAPACITOR, 10V, 1 μ F	30
C 266	F1L3D102A003	CAPACITOR, 2000V, 1000pF	1
C 293, 294	F1G1H9R0A544	CAPACITOR, 50V, 10pF	2
C 297, 507	F1J1E334A081	CAPACITOR, 25V, 0.33 μ F	2
C 300, 311, 312	F1G1H271A495	CAPACITOR, 50V, 270pF	3
C 321, 322, 323, 324, 325, 587, 588	F1J1E105A080	CAPACITOR, 25V, 1 μ F	7
C 337, 361, 426, 427, 518, 543, 559, 620, 741, 743	F1G1H1010005	CAPACITOR, 50V, 100pF	10
C 351, 396, 476, 483, 484, 486, 505, 506, 524, 545, 566, 713	F1J0J475A009	CAPACITOR, 6.3V, 4.7 μ F	12
C 365, 367, 370	F1G0J334A001	CAPACITOR, 6.3V, 0.33 μ F	3
C 379, 381, 746	F1L0J107A017	CAPACITOR, 6.3V, 100 μ F	3
C 380, 421, 516, 534, 551, 556, 597, 698	F1K1E1060001	CAPACITOR, 25V, 10 μ F	8
C 386, 502, 538, 548, 629	F1G1H221A495	CAPACITOR, 50V, 220pF	5
C 388, 391	F1H1A474A028	CAPACITOR, 10V, 0.47 μ F	2
C 450, 499, 536, 539, 560, 567, 595, 598, 600, 602, 604, 605	F1H1H104A748	CAPACITOR, 50V, 0.1 μ F	12
C 467, 469	F1G1A683A014	CAPACITOR, 10V, 0.068 μ F	2
C 491	F1G1H820A542	CAPACITOR, 50V, 82pF	1
C 492, 495	F1G1H561A496	CAPACITOR, 50V, 560pF	2
C 494, 624	F1H1H1830001	CAPACITOR, 50V, 0.018 μ F	2
C 501, 570, 623	F1G1H331A496	CAPACITOR, 50V, 330pF	3
C 504, 619	F1G1H222A496	CAPACITOR, 50V, 2200pF	2
C 508, 509, 510, 571, 596, 606, 614, 615	F1L1E106A017	CAPACITOR, 25V, 10 μ F	8
C 517, 546, 558, 616	F1H1C224A074	CAPACITOR, 16V, 0.22 μ F	4
C 519, 638	F1H1H182A748	CAPACITOR, 50V, 1800pF	2
C 520	F1H1H103A748	CAPACITOR, 50V, 0.01 μ F	1
C 530, 532	F2H0D101A003	CAPACITOR, 2V, 100 μ F	2
C 537	F1G1H182A496	CAPACITOR, 50V, 1800pF	1
C 541, 565	F1G1H220A542	CAPACITOR, 50V, 22pF	2
C 549	F1G1H472A496	CAPACITOR, 50V, 4700pF	1
C 553, 554	EEFCX0J101R	CAPACITOR, 6.3V, 100 μ F	2
C 562, 621	F1G1H470A542	CAPACITOR, 50V, 47pF	2
C 563, 838, 842, 843, 848	F1G1H471A496	CAPACITOR, 50V, 470pF	5
C 572	EEFCD0G101ER	CAPACITOR, 4V, 100 μ F	1
C 573, 813	F1G1C473A004	CAPACITOR, 16V, 0.047 μ F	2
C 601	F1G1H152A496	CAPACITOR, 50V, 1500pF	1
C 607, 608, 609	F1L1C106A008	CAPACITOR, 16V, 10 μ F	3
C 612	EEFSX0D471XE	CAPACITOR, 2V, 470 μ F	1
C 631	F1G1H391A496	CAPACITOR, 50V, 390pF	1
C 645, 646, 647, 648	F1J2A103A018	CAPACITOR, 100V, 0.01 μ F	4
C 704	F1G1E562A062	CAPACITOR, 25V, 5600p	1
C 720	F1G1C223A004	CAPACITOR, 16V, 0.022 μ F	1
C 830, 831	F1G1H3R0A543	CAPACITOR, 50V, 3pF	2
CF 1, 5	D4CC11030026	THERMISTOR	2
CN 1	K1MN50AA0018	CONNECTOR	1
CN 2	K1MN40AA0018	CONNECTOR	1
CN 3	K1KA14AA0266	CONNECTOR	1
CN 4, 29	K1MY12BA0309	CONNECTOR	2
CN 5, 6	K1MY40A00001	CONNECTOR	2

CN 7, 8, 11, 30		K1MY40BA0220	CONNECTOR	4
CN 9		K1KY10BA0214	CONNECTOR	1
CN 10		K1MN80BA0246	CONNECTOR	1
CN 12		K1MY30AA0158	FPC CONNECTOR	1
CN 13		K1MY13BA0102	CONNECTOR	1
CN 14		K1MY16BA0097	CONNECTOR	1
CN 15		K1MY07BA0096	CONNECTOR	1
CN 16		K1KB30AA0049	CONNECTOR	1
CN 17		K1KA30BA0060	CONNECTOR	1
CN 18		K1MY08BA0309	FPC CONNECTOR	1
CN 19		K1KA02AA0051	CONNECTOR	1
CN 20		K1KA08AA0266	CONNECTOR	1
CN 21		K1MYL0B00003	CONNECTOR	1
CN 22		K1MYL0B00004	CONNECTOR	1
CN 24		K1KY12A00004	CONNECTOR	1
CN 25		K1MY10BA0309	CONNECTOR	1
CN 26		K1KA02BA0014	CONNECTOR	1
CN 28		K1FY104B0009	CONNECTOR	1
CN 31		K1KA12BA0014	CONNECTOR	1
CN 37		K1MY52BA0190	CONNECTOR	1
CN 46		K1KA02AA0299	CONNECTOR	1
CN 47		K1MY24BA0311	FPC CONNECTOR	1
D 6, 7, 19, 58, 59, 721		MA2J72900L	DIODE	6
D 8, 9, 10, 11, 12, 13, 14, 15, 16, 17, 20, 21, 22		B0ADCJ000041	DIODE	13
D 24		B0JCRD000015	DIODE	1
D 25, 29, 30, 53, 60		B0JCMD000046	DIODE	5
D 26		B0JCCE000008	DIODE	1
D 28, 31		B0ADCJ000025	DIODE	2
D 33, 34, 35, 36, 37, 38,		MAZ80620ML	DIODE	7
D 39, 55		MA3S132E0L	DIODE	2
D 40		B2ABAM000002	DIODE	1
D 42		MA2S11100L	DIODE	1
D 43, 45, 50, 57, 64		B0JDBE000002	DIODE	5
D 44		B0JDRE000007	DIODE	1
D 46, 48		B0JCSE000006	DIODE	2
D 51		MAZ81200ML	DIODE	1
D 52		MAZ81800ML	DIODE	1
D 54		B0KB00000044	DIODE	1
D 714, 715, 716, 717, 718, 719, 720, 801		B0BD5R6A0005	DIODE	8
F 1, 4, 7	⚠	K5H502Z00003	FUSE, 5A, 32V	3
F 2, 5, 6, 8, 12	⚠	K5H202Z00005	FUSE, 2A, 32V	5
F 3	⚠	K5H402Z00003	FUSE, 4A, 32V	1
F 10	⚠	K5H802300002	FUSE, 8A, 72V	1
F 11	⚠	K5H123Y00001	FUSE, 12A, 65V	1
IC 1		C2GBD0000052	CPU	1
IC 2		C1CB00003067	CORE CHIP(GMCH)	1
IC 3		C1CB00003007	LSI	1
IC 4		C1CB00003068	CORE CHIP(ICH)	1
IC 5		C1CB00003035	LSI	1
IC 11		C0DBAYY00423	IC	1
IC 12, 13		C0DBALH00003	IC	2
IC 15		C1CB00003002	THERMAL SENSOR	1
IC 21		C0DBFYY00042	VOLTAGE REGULATOR	1
IC 23		C0DBZYY00265	POWER MANAGEMENT SWITCH	1
IC 24		C0DBZYY00016	IC	1
IC 25		C0ZBZ0000978	IC	1

IC 27		C3FBNY000187	FLASH ROM	1
IC 28		C2CBYY000639	IC	1
IC 29		C0CBCBC00181	IC	1
IC 30		C1CB00002983	LSI	1
IC 31, 86, 93		C0JBAS000215	IC, GATE LOGIC	3
IC 32, 61, 68, 87, 108, 704, 720, 721		C0JBAA000362	IC, LOGIC	8
IC 33		C0ABZA000047	IC, AMP	1
IC 34, 35, 36, 707		C0EBE0000459	IC	4
IC 37, 78		C0EBH0000457	IC	2
IC 38, 39		C0DBZYY00026	IC, USB POWER SW	2
IC 40		C0DBAYY00194	IC, DC/DC	1
IC 41		C0DBEFH00002	IC, REGULATOR	1
IC 42		C0EBE0000124	IC	1
IC 43, 44		C0EBH0000336	IC	2
IC 45		C0DBDJH00009	IC, LINER	1
IC 50		C1CB00003064	IC, CARD BUS CONTROLLER	1
IC 51		C1DB00001159	IC, PERIPHERAL LSI	1
IC 52		C0CBCBC00137	IC, REGULATOR	1
IC 54, 63, 64, 66		C0JBAA000345	IC, LOGIC	4
IC 55, 110		C0JBAB000624	IC	2
IC 56		C0JBAE000321	IC, LOGIC	1
IC 62		C0JBAA000511	IC	1
IC 65, 71, 72, 96, 101, 719		C0JBAB000621	IC, LOGIC	6
IC 67		C1CB00002790	IC, SECURITY CHIP	1
IC 70		C0ABBA000093	IC, OP AMP	1
IC 76, 701		C3EBDY000005	IC, EEPROM	2
IC 77, 717		C1CB00002585	IC	2
IC 79, 80, 88		C0JBAZ002836	IC, LOGIC	3
IC 81		C0DBFYY00049	REGULATOR	1
IC 83		C1CB00003000	PCI EXPRESS TO PATA HOST BUS ADAPTER	1
IC 84		C0JBAZ002837	IC, LOGIC	1
IC 85		C0JBAC000367	IC, LOGIC	1
IC 92		C1CB00002497	IC, USB HUB	1
IC 94, 95		C0JBAZ002372	IC, LOGIC	2
IC 99		AN12945A-VB	IC, AUDIO AMP	1
IC 100		C0JBAC000363	GATE LOGIC	1
IC 113, 703		C0JBAA000381	IC, LOGIC	2
IC 114, 712		C0JBAZ002192	IC	2
IC 126		C0DBAYY00282	DC/DC CONTROLLER FOR GMCH	1
IC 702		C0DBFYY00031	IC	1
IC 708		C0JBAD000194	1GATE LOGIC IC	1
IC 713		C0DBEFE00003	IC	1
IC 715		C0EBY0000419	IC, VOLTAGE DETECTOR	1
JK 1	△	K2EYB000001	JACK	1
L 1		G1CR82M00006	COIL	1
L 8, 9		J0MAB0000169	INDUCTOR	2
L 10, 11, 15, 16		J0JCC0000186	INDUCTOR	4
L 12, 27, 704, 705, 706,		J0JJC0000015	INDUCTOR	6
L 17		G1CR56ZA0140	INDUCTOR	1
L 18, 20		G1C2R8MA0240	COIL	2
L 19, 21		G1C4R7MA0240	CHOK COIL	2
L 22		G1C100M00030	COIL	1
L 23, 53		J0JKC0000007	INDUCTOR	2
L 24		G1A160HA0032	COIL	1
L 25		G1BYYYY00009	INDUCTOR	1
L 26, 727, 728, 729, 731		J0MAB0000200	INDUCTOR	5

L 48, 64, 69, 70, 71		J0JYC0000098	DC POWER LINE BEADS	5
L 49		G1C1R0MA0380	DC POWER LINE INDUCTOR	1
L 50, 715		G1C1R0MA0289	DC POWER LINE INDUCTOR	2
L 52		G1C100MA0077	COIL	1
L 65, 80, 711, 712, 713, 716, 718		J0JHC0000078	DC POWER LINE BEADS	7
L 700, 701, 714, 719, 721, 730		J0JJC0000022	DC POWER LINE BEADS	6
L 709, 710		G1C100M00038	INDUCTOR	2
L 722, 723, 724, 725		G1C470MA0330	DC POWER LINE INDUCTOR	4
PA 6	△	D4FB1R100015	OVER CURRENT PROTECTOR	1
Q 1, 52, 53, 66, 96, 123, 130, 131, 133, 135, 142, 144, 153, 700, 701, 702,		B1CFGD000023	TRANSISTOR	17
Q 7, 18, 39, 94, 100, 729		UP04213G0L	TRANSISTOR	6
Q 9, 20, 47, 49, 127, 159		B1DHDC000028	TRANSISTOR	6
Q 14, 25, 75, 76, 90, 99, 111, 112, 134, 145, 158, 727, 731, 744, 754		UNR9113J0L	TRANSISTOR	15
Q 16, 30, 31, 33, 69, 81, 82, 83, 85, 86, 87, 88, 89, 101, 102, 103, 104, 107, 108, 115, 119, 121, 126, 132, 138, 139, 141, 156, 157, 706, 730, 758, 759, 761, 762, 763, 764,		UNR9213J0L	TRANSISTOR	38
Q 22, 23, 24, 48, 50, 74, 77, 78, 91, 98, 109, 110, 117, 118, 120, 146, 743,		UNR9214J0L	TRANSISTOR	18
Q 26, 28, 38, 51		B1DDED000004	TRANSISTOR, FET	4
Q 27, 80, 745		B1MBFDG00001	FET	3
Q 40, 41, 42, 43, 44, 45, 137, 140		UP04116G0L	TRANSISTOR	8
Q 54, 56, 60, 61, 67, 68, 71, 72, 84, 151, 152		B1CFRD000014	FET	11
Q 55, 57		B1CFRD000020	FET	2
Q 65, 73		B1MBEDG00001	FET	2
Q 70, 93		B1CFGD000003	TRANSISTOR	2
Q 79, 105, 106, 113, 114, 122, 124, 136		B1CHRD000001	TRANSISTOR	8
Q 92, 97		B1DHDD000031	TRANSISTOR, FET	2
Q 116		UP04214G0L	TRANSISTOR	1
Q 125		B1MBEDA00008	TRANSISTOR	1
Q 728		B1CFNC000004	FET	1
Q 733		2SB0766ARL	TRANSISTOR	1
Q 742, 756		B1CFRD000025	FET	2
R 1, 778		ERJ2GEJ510X	RESISTOR, 1/16W, 51Ω	2
R 2, 5, 26, 27, 41, 42, 43, 118, 190, 191, 262, 263, 415, 873		ERJ2GEJ102X	RESISTOR, 1/16W, 1KΩ	14
R 3		D1H85104A024	RESISTOR ARRAY	1

R 6, 21, 22, 33, 45, 109, 157, 160, 162, 176, 182, 203, 204, 241, 280, 330, 352, 366, 369, 443, 444, 455, 461, 464, 474, 478, 484, 485, 486, 595, 597, 647, 668, 690, 703, 724, 732, 734, 746, 759, 767, 768, 780, 781, 795, 797, 799, 811, 812, 813, 827, 830, 831, 849, 862, 863, 865, 892, 896, 898, 899, 901, 902, 911, 912, 919, 920, 921, 936, 941, 951		ERJ2GE0R00X	RESISTOR, 1/16W, 0Ω	71
R 7, 31, 66, 68, 70, 473, 481, 518, 650, 657		ERJ2RKF1001X	RESISTOR, 1/16W, 1KΩ	10
R 8, 32		ERJ2RKF2001X	RESISTOR, 1/16W, 2KΩ	2
R 9, 10, 240, 374, 375, 402, 429, 482, 564, 565, 566, 567, 568, 569, 631, 677, 721, 725, 770, 787, 908, 909		ERJ2GEJ101X	RESISTOR, 1/16W, 100Ω	22
R 13, 15		ERJ2RKF27R4X	RESISTOR, 1/16W, 27.4Ω	2
R 14, 16, 25, 853		ERJ2RKF54R9X	RESISTOR, 1/16W, 54.9Ω	4
R 18		ERJ2RKF68R0X	RESISTOR, 1/16W, 68Ω	1
R 19, 23, 24, 92, 97, 743, 894, 910		ERJ2GEJ560X	RESISTOR, 1/16W, 56Ω	8
R 20, 253, 334, 515, 516, 527, 528, 540, 541, 553, 554, 907		ERJ2GEJ100X	RESISTOR, 1/16W, 10Ω	12
R 28, 605, 606, 607, 615		ERJ2GEJ562X	RESISTOR, 1/16W, 5.6KΩ	5
R 29		ERJ2RKF2210X	RESISTOR, 1/16W, 221Ω	1
R 30		ERJ2RKF1000X	RESISTOR, 1/16W, 100Ω	1
R 34, 137, 177, 722		ERJ2RKF24R9X	RESISTOR, 1/16W, 24.9Ω	4
R 48, 49, 102, 107, 145, 168, 181, 183, 251, 252, 256, 258, 269, 270, 271, 272, 273, 274, 275, 278, 279, 281, 333, 344, 350, 373, 389, 391, 393, 411, 420, 421, 424, 428, 431, 440, 441, 442, 445, 446, 448, 453, 470, 522, 523, 524, 543, 549, 575, 576, 577, 608, 609, 708, 720, 728, 747, 756, 757, 765, 802, 814, 820, 821, 829, 836, 837, 838, 840, 841, 843, 867, 870, 880, 884, 905, 915, 923, 933, 934, 952, 953, 955		ERJ2GEJ103X	RESISTOR, 1/16W, 10KΩ	83
R 64, 65		ERJ2RKF80R6X	RESISTOR, 1/16W, 80.6Ω	2
R 67, 796		ERJ2RKF4990X	RESISTOR, 1/16W, 499Ω	2
R 69, 480, 626, 627		ERJ2RHD302X	RESISTOR, 1/16W, 3KΩ	4
R 71, 72, 111, 242, 244, 276, 321, 331, 332, 351, 414, 694, 695, 696, 697, 809, 810, 868, 940		ERJ2GEJ330X	RESISTOR, 1/16W, 33Ω	19
R 74		ERJ2RKF1021X	RESISTOR, 1/16W, 1.02KΩ	1
R 75		ERJ2RKF2371X	RESISTOR, 1/16W, 2370Ω	1
R 76, 77, 78		ERJ2RKF1500X	RESISTOR, 1/16W, 150Ω	3
R 81		ERJ2RKF49R9X	RESISTOR, 1/16W, 49.9Ω	1

R 85, 245, 491, 492, 498, 499, 624, 632, 634, 744, 881, 882, 889, 895, 897, 900, 922	ERJ3GEY0R00V	RESISTOR, 1/16W, 0Ω	17
R 86, 890	ERJ2GEJ1R0X	RESISTOR, 1/16W, 1Ω	2
R 93, 94, 96, 98, 99, 101	D1HY5608A007	RESISTOR ARRAY	6
R 95, 100, 248	D1H85604A024	RESISTOR ARRAY	3
R 104, 112, 113, 131, 259, 385, 390, 392, 418, 432, 816	D1H81034A024	RESISTOR ARRAY	11
R 105, 106, 188, 189, 803, 804, 805, 806, 807, 808	D1H83304A024	RESISTOR ARRAY	10
R 108, 173, 454, 559, 560, 561, 562, 563, 772, 773, 774, 775, 776, 777, 800, 801	ERJ2GEJ105X	RESISTOR, 1/16W, 1MΩ	16
R 126	D1H84724A024	RESISTOR ARRAY	1
R 129, 130, 185, 186, 187, 257, 264, 265, 266, 267, 268, 306, 307, 308, 437	D1HY1038A007	RESISTOR, ARRAY	15
R 151, 153	ERJ2RKF3241X	RESISTOR, 1/16W, 3240Ω	2
R 152, 154	ERJ2RKF4530X	RESISTOR, 1/16W, 453Ω	2
R 155, 178	ERJ2GEJ121X	RESISTOR, 1/16W, 120Ω	2
R 166, 169	ERJ2RKF3323X	RESISTOR, 1/16W, 332KΩ	2
R 171, 338, 339, 719	ERJ2GEJ203X	RESISTOR, 1/16W, 20KΩ	4
R 172	ERJ2GEJ106X	RESISTOR, 1/16W, 10MΩ	1
R 179	ERJ2GEJ331X	RESISTOR, 1/16W, 330Ω	1
R 192, 198, 246, 309, 310, 315, 342, 347, 353, 357, 359, 360, 382, 404, 405, 406, 407, 408, 433, 451, 456, 457, 458, 459, 503, 558, 602, 610, 611, 639, 671, 685, 686, 688, 699, 711, 723, 745, 748, 750, 764, 769, 839, 842, 858, 859, 927, 956, 957	ERJ2GEJ104X	RESISTOR, 1/16W, 100KΩ	49
R 193, 200, 354, 361, 362, 363, 383, 410, 425, 539, 557, 600, 601, 613	ERJ2GEJ474X	RESISTOR, 1/16W, 470KΩ	14
R 236	D1H87504A024	RESISTOR ARRAY	1
R 249, 651	ERJ2RKF5101X	RESISTOR, 1/16W, 5.1KΩ	2
R 254, 290, 327, 328, 345, 376, 377, 552, 832, 834, 864	ERJ2RHD103X	RESISTOR, 1/16W, 10KΩ	11
R 260, 426, 427, 449, 579, 580, 625, 846, 847, 850, 851, 852	ERJ2GEJ472X	RESISTOR, 1/16W, 4.7KΩ	12
R 284, 835, 942, 943, 944	ERJ2GEJ150X	RESISTOR, 1/16W, 15Ω	5
R 287	ERJ2RKF5602X	RESISTOR, 1/16W, 56KΩ	1
R 288, 289, 305	ERJ2RKF3901X	RESISTOR, 1/16W, 3.9KΩ	3
R 311	ERJ2RHD3922X	RESISTOR, 1/16W, 39.2KΩ	1
R 312, 387	D1H84734A024	RESISTOR ARRAY	2
R 313, 519, 547	ERJ2RHD203X	RESISTOR, 1/16W, 20KΩ	3
R 317	ERJ2GEJ273X	RESISTOR, 1/16W, 27KΩ	1
R 320, 346	ERJ6GEY0R00V	RESISTOR, 1/10W, 0Ω	2
R 322, 335	ERJ2RKF2671X	RESISTOR, 1/16W, 2.67KΩ	2
R 323	ERJ2GEJ272X	RESISTOR, 1/16W, 2.7KΩ	1
R 324, 325, 533, 534	ERJ2RKF5601X	RESISTOR, 1/16W, 5.6KΩ	4
R 336, 337	ERJ2GEJ333X	RESISTOR, 1/16W, 33KΩ	2
R 340, 341, 367, 371, 472, 545, 582, 583, 731, 737	ERJ2RHD104X	RESISTOR, 1/16W, 100KΩ	10

R 348		ERJ2RKF1602X	RESISTOR, 1/16W, 16KΩ	1
R 349		ERJ2RKF9091X	RESISTOR, 1/16W, 9.09KΩ	1
R 365		ERJ2RKD684X	RESISTOR, 1/16W, 680KΩ	1
R 368, 370, 655, 738		ERJ2RKD154X	RESISTOR, 1/16W, 150KΩ	4
R 372		D1ZZ00000046	RESISTOR, 1W, 5mΩ	1
R 388		D1H81014A024	RESISTOR ARRAY	1
R 394, 398, 438		ERJ2GEJ181X	RESISTOR, 1/16W, 180Ω	3
R 395, 397, 477, 660		ERJ2GEJ471X	RESISTOR, 1/16W, 470Ω	4
R 396, 399, 510		ERJ2GEJ221X	RESISTOR, 1/16W, 220Ω	3
R 400, 401		D1H82214A024	RESISTOR, 1/16W, 220Ω	2
R 416		D1H81004A024	RESISTOR ARRAY	1
R 422, 423, 790, 791		ERJ2GEJ222X	RESISTOR, 1/16W, 2.2KΩ	4
R 450, 538, 588, 592, 593, 598, 599		ERJ2GEJ473X	RESISTOR, 1/16W, 47KΩ	7
R 452		ERJ2RKF1202X	RESISTOR, 1/16W, 12KΩ	1
R 466		ERJ2RKF2003X	RESISTOR, 1/16W, 510KΩ	1
R 467, 587, 735		ERJ2RKF4702X	RESISTOR, 1/16W, 47KΩ	3
R 468		ERJ2RKF6801X	RESISTOR, 1/16W, 6.80KΩ	1
R 469, 648		ERJ2GEJ393X	RESISTOR, 1/16W, 39KΩ	2
R 471		ERJ2RKF1800X	RESISTOR, 1/16W, 180Ω	1
R 475		ERJ2RKF1102X	RESISTOR, 1/16W, 11KΩ	1
R 476, 488, 489, 490		ERJ3GEYJ1R0V	RESISTOR, 1/16W, 1Ω	4
R 479		ERJ2RHD1801X	RESISTOR, 1/16W, 2.2KΩ	1
R 487, 645		ERJ3GEYJ101V	RESISTOR, 1/16W, 100Ω	2
R 493, 630		D1ZZ00000093	RESISTOR, 1W, 1mΩ	2
R 494, 495, 511, 529, 530, 532, 537, 555		D1BDR022A099	RESISTOR, 1/3W, 0.022Ω	8
R 500		ERJ2RKF8202X	RESISTOR, 1/16W, 82KΩ	1
R 501, 517, 544, 633, 640, 749		ERJ3GEYJ100V	RESISTOR, 1/16W, 10Ω	6
R 502		ERJ3GEYJ102V	RESISTOR, 1/10W, 1 KΩ	1
R 512, 531, 536, 556		D1BDR033A099	RESISTOR, 1/3W, 0.033Ω	4
R 520		ERJ2RHD243X	RESISTOR, 1/16W, 24KΩ	1
R 521, 542		ERJ2GEJ153X	RESISTOR, 1/16W, 15KΩ	2
R 525		ERJ2RHD472X	RESISTOR, 1/16W, 4.7KΩ	1
R 526, 586		ERJ2RHD153X	RESISTOR, 1/16W, 15KΩ	2
R 535		ERJ2RKF1302X	RESISTOR, 1/16W, 13KΩ	1
R 546, 654		ERJ2RHD622X	RESISTOR, 1/16W, 6.2KΩ	2
R 548, 570, 636, 637, 641, 642, 643		ERJ2GEJ223X	RESISTOR, 1/16W, 22KΩ	7
R 550		ERJ2RKF1301X	RESISTOR, 1/16W, 1.3KΩ	1
R 551, 833		ERJ2RHD303X	RESISTOR, 1/16W, 30KΩ	2
R 571, 572		ERJ6GEYJ122V	RESISTOR, 1/10W, 1.2KΩ	2
R 573, 574		ERJ6GEYJ222V	RESISTOR, 1/10W, 2.2KΩ	2
R 578, 581, 594, 596		ERJ2GEJ564X	RESISTOR, 1/16W, 560KΩ	4
R 584, 585		ERJ2RKF3302X	RESISTOR, 1/16W, 33KΩ	2
R 589, 590		ERJ2GEJ3R3X	RESISTOR, 1/16W, 3.3Ω	2
R 603		ERJ3GEYJ562V	RESISTOR, 1/16W, 5.6KΩ	1
R 604		D1BDR4700001	RESISTOR, 1/8W, 0.47Ω	1
R 612, 659, 736		ERJ2RKD114X	RESISTOR, 1/16W, 110KΩ	3
R 614		ERJ2RHD3652X	RESISTOR, 1/16W, 36.5KΩ	1
R 616		ERJ2GEJ154X	RESISTOR, 1/16W, 150KΩ	1
R 617, 618, 619		D1BDR1000002	RESISTOR, 1/8W, 0.1Ω	3
R 620		D1BDR1500002	RESISTOR, 1/8W, 0.15Ω	1
R 622		ERA3EKB1623V	RESISTOR, 1/16W, 162KΩ	1
R 623		ERA3EEB1692V	RESISTOR, 1/16W, 16.9KΩ	1
R 628, 629		D1BDR068A100	RESISTOR, 1/3W, 0.068Ω	2
R 635		ERJ3GEYJ2R2V	RESISTOR, 1/16W, 2.2Ω	1

R 656		ERJ2RKF6981X	RESISTOR, 1/16W, 6.98KΩ	1
R 658		ERJ2RKF1501X	RESISTOR, 1/16W, 1.5KΩ	1
R 661, 662		ERJ2GEJ392X	RESISTOR, 1/16W, 3.9W	2
R 663, 664, 914		ERJ2GEJ4R7X	RESISTOR, 1/16W, 4.7Ω	3
R 712		D1HY1048A007	RESISTOR, 1/16W, 10KΩ	1
R 729, 730		ERJ2RKF56R0X	RESISTOR, 1/16W, 56Ω	2
R 751		ERJ2GEJ511X	RESISTOR, 1/16W, 510Ω	1
R 792, 793, 794		ERJ2RKF75R0X	RESISTOR, 1/16W, 75Ω	3
R 823, 824		ERJ2RKF6041X	RESISTOR, 1/16W, 6.04KΩ	2
R 872		ERJ2GEJ681X	RESISTOR, 1/16W, 680Ω	1
R 876		ERJ2RKF4991X	RESISTOR, 1/16W, 4.99KΩ	1
R 879		ERJ2GEJ512X	RESISTOR, 1/16W, 5.1KΩ	1
R 913		ERJ2GEJ2R2X	RESISTOR, 1/16W, 2.2Ω	1
R 925, 926		ERJ2GEJ332X	RESISTOR, 1/16W, 3.3KΩ	2
R 929		ERJ2RKF4750X	RESISTOR, 1/16W, 475Ω	1
R 950		ERJ2RKF22R6X	RESISTOR, 1/16W, 22.6Ω	1
T 1, 2		G5BYC0000015	TRANCE	2
X 1		H0J143500079	CRYSTAL OSCILLATOR	1
X 2		H0J327200085	CRYSTAL OSCILLATOR	1
X 3		H0J2505A0053	CRYSTAL OSCILLATOR	1
X 5		H2D200500011	CERAMIC LOCK	1
X 6		H0J245500083	XTAL	1
X 7		H0J240500033	XTAL	1
ZA 1, 2, 7		K1YGZZ000060	SPACER	3
ZA 3, 4		K1YGZZ000065	SPACER	2
EXT. ANTENNA PCB				
CN 1, 2		K1QZA1AE0001	CONNECTOR	2
CN 3		K1QZB1AA0023	COAXIAL CONNECTOR	1
C 2		ECUV1H010CCV	CAPACITOR, 50V, 1pF	1
C 4		ECUV1H020CCV	CAPACITOR, 50V, 2pF	1
C 5		ELJRE2N2DFA	CHIP INDUCTER	1
L 1		ECUV1H070DCV	CAPACITOR, 50V, 7pF	1
L 2		ELJRE1N0DFA	CHIP INDUCTOR	1
L 3		ECUV1H060DCV	CAPACITOR, 50V, 6pF	1
BLUETOOTH PCB				
C 1		F1J0J106A016	CAPACITOR, 6.3V, 10μF	1
C 2, 4, 7		F1G1C104A042	CAPACITOR, 16V, 0.1μF	3
C 3, 5		F1G1H102A496	CAPACITOR, 50V, 1000pF	2
C 6, 9		F1G1E103A062	CAPACITOR, 25V, 0.01μF	2
C 8		F1G1H270A542	CAPACITOR, 50V, 27pF	1
C 10		F1G1HR50A543	CAPACITOR, 50V, 0.5pF	1
CN 1		K1MN10BA0070	CONNECTOR	1
IC 1		C0JBAZ002422	IC, FET SWITCH	1
IC 2		N5HZZ0000056	BLUETOOTH MODULE	1
IC 3		C0EBE0000460	IC	1
IC 5		C0JBAC000382	IC, LOGIC	1
JK 1		K1QZA1AE0001	CONNECTOR	1
L 1,2		J0JJC0000015	INDUCTOR	1
L 4		G1C5N6ZA0029	INDUCTOR	1
Q 1		B1GBCFNN0042	TRANSISTOR	1
Q 2		B1DHDC000028	TRANSISTOR	1
R 1, 2, 3		ERJ2GEJ103X	RESISTOR, 1/16W, 10KΩ	3
SD PCB				
C 300		F1G1A104A014	CAPACITOR, 10V, 0.1μF	1
CN 300		K1MN12BA0134	CONNECTOR	1
CN 301		K1NA09E00076	CONNECTOR	1
D 300		B3ACB0000207	LED	1

R 300		ERJ2GEJ101X	RESISTOR, 1/16W, 100Ω	1
USB PCB				
C 100, 101, 102		EEFCX0J121R	CAPACITOR, 6.3V, 120μF	3
CN 100		K1KA14BA0014	CONNECTOR	1
CN 101, 102, 103		K1FY104BA024	CONNECTOR, USB	3
D 100, 101, 102		B0KB00000044	DIODE	3
L 100, 101, 102		J0MAB0000212	COMMON MODE FILTER	3
L 103, 104, 105, 106, 107, 108		DDB5Z031J-L	INDUCTOR	6
MP PCB				
CN 400, 401		K1MN40B00048	CONNECTOR	2
CN 402		K1KA62B00003	CONNECTOR	1
F 401	△	K5H103A00004	FUSE, 10A, 125V	1
IO PCB				
C 700, 702, 718, 738, 739, 747		F1G1C104A042	CAPACITOR, 16V, 0.1μF	6
C 701		F1H1H104A748	CAPACITOR, 50V, 0.1μF	1
C 703, 704, 705, 706, 707, 708, 709, 710, 741, 742		F1G1H1010005	CAPACITOR, 50V, 100pF	10
C 712, 715		F1G1H330A542	CAPACITOR, 50V, 33pF	2
C 736, 737		F1G1H102A496	CAPACITOR, 50V, 1000pF	2
C 740		F1H1A1050015	CAPACITOR, 10V, 1μF	1
C 754		F1G1A104A014	CAPACITOR, 10V, 0.1μF	1
CN 700		K1MY50BA0220	CONNECTOR	1
CN 701		K1MN40B00048	CONNECTOR	1
CN 702		K1FA209BA004	CONNECTOR	1
CN 703		K1FB115BA014	CONNECTOR	1
CN 705		K1FY180BA001	CONNECTOR	1
F 701	△	K5Y802A00003	FUSE, 8A, 125V	1
FL 703, 704, 705		J0HAAC000059	FILTER	3
JK 700, 701		K2HC103B0197	JACK	2
L 700, 701, 702, 703, 704, 705, 706, 707		DDB5Z021G-Y	INDUCTOR	8
L 711, 712		J0JCC0000186	INDUCTOR	2
L 713, 714, 721, 722, 723		J0JCC0000078	INDUCTOR	5
L 715, 716, 717, 718, 719		J0JCC0000077	INDUCTOR	5
L 720		J0JHC0000032	INDUCTOR	1
PA 700	△	D4FB1R100015	OVER CURRENT PROTECTOR	1
R 700, 701, 702		ERJ2RKF1500X	RESISTOR, 1/16W, 150Ω	3
R 704		EZJP0V080KA	VARISTOR	1
R 706, 719		ERJ2GEJ472X	RESISTOR, 1/16W, 4.7KΩ	2
R 711, 712, 713, 714, 722, 723		ERJ2GE0R00X	RESISTOR, 1/16W, 0Ω	6
R 716		ERJ2GEJ101X	RESISTOR, 1/16W, 100Ω	1
R 717, 718		ERJ2GEJ221X	RESISTOR, 1/16W, 220Ω	2
R 720, 721		ERJ3GEY0R00V	RESISTOR, 1/16W, 0Ω	2
PAD PCB				
C 800, 804		F1H1A1050015	CAPACITOR, 10V, 1μF	2
C 801, 802		F1G1H681A496	CAPACITOR, 50V, 680pF	2
C 803		F1G1C104A042	CAPACITOR, 16V, 0.1μF	1
CN 800		K1MN14BA0059	CONNECTOR	1
CN 801		K1MY04BA0334	CONNECTOR	1
CN 802		K1MN10BA0059	CONNECTOR	1
D 800		DED1SS355T17	DIODE	1
IC 800		C1DB00001417	IC, FLAT PAD CONTROLLER	1
Q 800, 801		B1GKCFJN0004	TRANSISTOR	2
R 800		ERJ2GEJ224X	RESISTOR, 1/16W, 220KΩ	1
R 801, 803		ERJ2GEJ822X	RESISTOR, 1/16W, 8.2KΩ	2

R 802		ERJ2GEJ273X	RESISTOR, 1/16W, 27KΩ	1
R 804		ERJ2GEJ105X	RESISTOR, 1/16W, 1MΩ	1
R 805, 806		ERJ2GEJ222X	RESISTOR, 1/16W, 2.2KΩ	2
R 808		D1H81034A024	RESISTOR ARRAY	1
SW 800, 801		EVQPLDA15	SWITCH	2
X 800		H2D400400012	OSCILLATOR, 4MHz	1
LED PCB				
CN 901		K1MN10AA0058	CONNECTOR	1
D 901, 902, 905, 906, 907		B3ABB0000210	DIODE	5
D 903		B3ADB0000065	DIODE	1
D 904		B3AGB0000040	DIODE	1
ANTENNA SW PCB				
C 1, 2, 3		F1H1H101A737	CAPACITOR, 50V, 100pF	3
C 4, 5		F1G1H102A496	CAPACITOR, 50V, 1000pF	2
C 6		F1G1C104A042	CAPACITOR, 16V, 0.1μF	1
C 7, 8		F1H0J105A002	CAPACITOR, 6.3V, 1μF	2
CN 1		K1MN06BA0160	CONNECTOR	1
CN 2, 3, 4		K1QZA1AE0001	CONNECTOR	3
IC 1		C1CB00002426	SPDT SWITCH IC	1
IC 2		C0CBCAC00259	REGULATOR	1
IC 3		C0JBAA000362	IC, LOGIC	1
R 1		ERJ2GE0R00X	RESISTOR, 1/16W, 0Ω	1
DOCKING PCB				
CN 201		K1MN50AA0018	CONNECTOR	1
CN 202		K1KA50AA0237	SOCKET	1
CN 203		K1QZB1AA0017	CONNECTOR	1
CN 204		K1QZA1AE0001	CONNECTOR	1
TOUCH PANEL PCB				
C 200, 201, 202, 203		F1G1E472A062	CAPACITOR, 25V, 4700pF	4
C 204, 205, 206, 207		F1G1H681A496	CAPACITOR, 50V, 680pF	4
C 208, 211, 212		F1G1C104A042	CAPACITOR, 16V, 0.1μF	3
C 209		F1G1E223A062	CAPACITOR, 25V, 0.022μF	1
C 210		F1G1H102A496	CAPACITOR, 50V, 1000pF	1
C 213		F1J0J475A009	CAPACITOR, 6.3V, 4.7μF	1
C 214		F1G0J224A001	CAPACITOR, 6.3V, 0.22μF	1
C 216		F1J0J106A013	CAPACITOR, 6.3V, 10μF	1
CN 200		K1MN04BA0071	CONNECTER	1
CN 201		K1KA06BA0014	CONNECTOR	1
IC 200		C0EBE0000460	IC	1
IC 202		C1CB00002515	IC, TOUCHPANEL CONTROLLER	1
Q 200, 201		XP0431400L	TRANSISTOR	2
Q 202		UNR9113J0L	TRANSISTOR	1
Q 203		UNR9213J0L	TRANSISTOR	1
R 200, 206		ERJ2GEJ473X	RESISTOR, 1/16W, 47KΩ	2
R 203, 205, 207, 209, 210, 211, 212, 217, 220, 221, 222, 223		ERJ2GEJ102X	RESISTOR, 1/16W, 1KΩ	12
R 208		ERJ2GEJ273X	RESISTOR, 1/16W, 27KΩ	1
R 213, 214, 215, 216		ERJ2GEJ822X	RESISTOR, 1/16W, 8.2KΩ	4
R 218		ERJ2GEJ512X	RESISTOR, 1/16W, 5.1KΩ	1
R 226		DEARA8AJ473M	RESISTOR ARRAY	1
R 227, 228		ERJ2GEJ270X	RESISTOR, 1/16W, 27Ω	2
R 229		ERJ2GEJ152X	RESISTOR, 1/16W, 1.5KΩ	1
X 200		H2D600400005	OSCILLATOR, 6MHz	1