



# **Maintenance and Service Guide**

**Compaq Armada 110 and  
Compaq Evo N110**

Document Part Number: 238850-003

**December 2001**

This guide is a troubleshooting reference used for maintaining and servicing the notebook. It provides comprehensive information on identifying computer features, components, and spare parts, troubleshooting computer problems, and performing computer disassembly procedures.

© 2001 Compaq Information Technologies Group, L.P.

Compaq, the Compaq logo, Armada, and Evo are trademarks of Compaq Information Technologies Group, L.P. in the U.S. and/or other countries.

Microsoft and Windows are trademarks of Microsoft Corporation in the U.S. and/or other countries.

Intel, Pentium, and Celeron are trademarks of Intel Corporation in the U.S. and/or other countries.

All other product names mentioned herein may be trademarks of their respective companies.

Compaq shall not be liable for technical or editorial errors or omissions contained herein. The information in this document is provided "as is" without warranty of any kind and is subject to change without notice. The warranties for Compaq products are set forth in the express limited warranty statements accompanying such products. Nothing herein should be construed as constituting an additional warranty.

**Maintenance and Service Guide**

**Third Edition December 2001**

**Document Part Number: 238850-003**

---

# Contents

## 1 Product Description

1.1 Models and Features	1-1
Models	1-2
Features	1-6
1.2 Security	1-8
1.3 Power Management	1-9
Enabling Power Savings	1-9
Timeout Settings	1-9
Setting Standby	1-10
Hibernation	1-10
Standby	1-10
1.4 Computer External Components	1-11
1.4 Design Overview	1-20

## 2 Troubleshooting

Using the PhoenixBIOS Setup Utility	2-2
Troubleshooting Flowcharts for Portable Computers	2-3
2.1 Initial Troubleshooting	2-4
2.2 No Power, Part 1	2-5
2.3 No Power, Part 2	2-6
2.4 No Power, Part 3	2-7
2.5 No Power, Part 4	2-8
2.6 No Video, Part 1	2-9
2.7 No Video, Part 2	2-10
2.8 Non-Functioning Docking Station (if applicable).	2-11
2.9 No Operating System (OS) Loading	2-12
2.10 No OS Loading from Hard Drive, Part 1	2-13

- 2.11 No OS Loading from Hard Drive, Part 2. . . . . 2-14
- 2.12 No OS Loading from Hard Drive, Part 3. . . . . 2-15
- 2.13 No OS Loading from Diskette Drive. . . . . 2-16
- 2.14 No OS Loading from CD- or DVD-ROM Drive . . . . . 2-17
- 2.15 No Audio, Part 1 . . . . . 2-18
- 2.16 No Audio, Part 2 . . . . . 2-19
- 2.17 Non-Functioning Device . . . . . 2-20
- 2.18 Non-Functioning Keyboard. . . . . 2-21
- 2.19 Non-Functioning Pointing Device. . . . . 2-22
- 2.20 Network or Modem Connection . . . . . 2-23

**3 Illustrated Parts Catalog**

- 3.1 Serial Number Location . . . . . 3-1
- 3.2 Computer System Major Components . . . . . 3-2
- 3.3 Plastics Kit Components . . . . . 3-8
- 3.4 Hardware Kit Components. . . . . 3-9
- 3.5 Cable Kit Components . . . . . 3-10
- 3.6 Mass Storage Devices . . . . . 3-11
- 3.7 Miscellaneous. . . . . 3-12

**4 Removal and Replacement Preliminaries**

- 4.1 Tools Required. . . . . 4-1
- 4.2 Service Considerations. . . . . 4-1
  - Plastic Parts . . . . . 4-2
  - Cables and Connectors . . . . . 4-2
- 4.3 Preventing Damage to Removable Drives. . . . . 4-2
- 4.4 Preventing Electrostatic Damage. . . . . 4-4
- 4.5 Packaging and Transporting Precautions. . . . . 4-4
- 4.6 Workstation Precautions . . . . . 4-5
- 4.7 Grounding Equipment and Methods . . . . . 4-6

---

## 5 Removal and Replacement Procedures

5.1 Serial Number . . . . .	5-2
5.2 Disassembly Sequence Chart . . . . .	5-3
5.3 Preparing the Computer for Disassembly . . . . .	5-4
5.4 Computer Feet . . . . .	5-5
5.5 Mini PCI Communication Board . . . . .	5-6
5.6 LED Cover . . . . .	5-8
5.7 Keyboard . . . . .	5-9
5.8 Optical Drive . . . . .	5-12
5.9 Display . . . . .	5-14
5.10 Heat Sink . . . . .	5-18
5.11 Processor . . . . .	5-22
5.12 Top Cover . . . . .	5-24
5.13 Diskette Drive . . . . .	5-27
5.14 TouchPad . . . . .	5-29
5.15 Hard Drive . . . . .	5-32
5.16 Disk Cell Real Time Clock (RTC) Battery . . . . .	5-34
5.17 Fan . . . . .	5-36
5.18 System Board . . . . .	5-39

## 6 Specifications

### A Connector Pin Assignments

### B Power Cord Set Requirements

3-Conductor Power Cord Set . . . . .	B-1
General Requirements . . . . .	B-1
Country-Specific Requirements . . . . .	B-2
Notes . . . . .	B-3

### C Screw Listing

### Index

---

# Product Description

## 1.1 Models and Features

The Compaq Armada 110 and Evo N110 Series notebooks offer advanced modularity, Intel Pentium III or Intel Celeron processors with 64-bit architecture, industry-leading Accelerated Graphics Port (AGP) implementation, and extensive multimedia support.



*Figure 1–1: Compaq Armada 110 and Evo N110*

## Models

Computer models are shown in Table 1-1.

**Table 1-1  
Compaq Armada 110 and Evo N110  
Models and Model Naming Conventions**

Key										
N11	P	100	4X	20	V	C	128	98	9L	XXXXXX-XXX
1	2	3	4	5	6	7	8	9	10	11
Key	Description	Options								
1	Brand / Series designator	A=Armada N=Evo						11=110		
2	Processor type	P=Intel Pentium III C=Intel Celeron								
3	Processor speed	100=1.0 GHz 850=850 MHz						800=800 MHz 700=700 MHz		
4	Display type/size/resolution	4=14.x" 2=12.x"						X=XGA (1024 x 768) S=SVGA (800 x 600)		
5	Hard drive size	20=20 GB 15=15 GB						10=10.0 GB		
6	Optical drive designator	V=8X Max DVD-ROM drive						D=24X Max CD-ROM drive		
7	Integrated communication	M=modem 0=none						C=modem/NIC combination card		
8	RAM	64=64 MB						12=128 MB		
9	Operating system	8=Windows 98 Me=Windows Millennium Edition (Me)						8M=Windows 98/ME dual install 2K=Windows 2000		
10	Battery cells / type	L=9 cells, Lithium ion						H=9 cells, Nickel Metal Hydride		
11	SKU#									

**Table 1-1**  
**Compaq Armada 110 and Evo N110**  
**Models and Model Naming Conventions (*Continued*)**

1	2	3	4	5	6	7	8	9	10	11
N11	P	100	4X	20	V	C	25	2K	L	
Danish			470028-444			Italian			470028-462	
Dutch			470028-464			Spanish			470028-468	
European			470028-442			Swedish/Finnish			470028-473	
French			470028-449			Swiss			470028-478 &	
French			470028-417						470028-483	
Canadian						U.K. English			470028-485	
German			470028-454			U.S. English			470028-435	
Greek/Polish			470028-459							
N11	P	100	4X	20	V	C	12	2K	L	
Asia/Pacific			470028-515			Japanese			470028-409	
Australian			470028-489							
N11	P	100	4X	20	V	C	12	8	L	
People's Republic of China										470028-503
N11	P	100	4X	20	V	C	12	M	L	
Arabic			470028-402			Korean			470028-420	
Czech			470028-404			Norwegian			470028-411	
Dutch			470028-409			Portuguese			470028-412	
European			470028-403			Russian			470028-414	
Greek/Polish			470028-405			Slovakian/Slovenian			470028-416	
Hebrew			470028-407			Swedish/Finnish			470028-418	
Hong Kong			470028-423			Taiwanese			470028-421	
Hungarian			470028-406			Turkish			470028-420	

All Compaq Evo N110 computer models use configuration code **KFKZ**.



**Table 1-1**  
**Compaq Armada 110 and Evo N110**  
**Models and Model Naming Conventions (*Continued*)**

1	2	3	4	5	6	7	8	9	10	11
N11	C	100	4X	20	D	C	12	8M	L	
Asia Pacific/Thai			470028-598			Latin American				470028-441
Australian			470028-443			Spanish				
Danish			470028-428			Latin American				470028-497
French			470028-429			Spanish (NAFTA)				
French			470028-426			Spanish				470028-436
Canadian						Swiss				470028-438
German			470028-431							& 470028-439
Italian			470028-433			U.K. English				470028-440
Japanese			470028-445			U.S. English				470028-424
						U.S. English (NAFTA)				470028-496
N11	C	100	4X	20	D	C	12	2K	L	
Asia Pacific			470028-479			Greek/Polish				470028-460
Australian			470028-480			Italian				470028-461
Danish			472028-452			Japanese				470028-482
Dutch			470028-510			Spanish				470028-466
European			470028-451			Swedish/Finnish				470028-467
French			470028-455			Swiss				470028-470 &
French			470028-448							470028-471
Canadian						U.K. English				470028-474
German			470028-457			U.S. English				470028-447

All Compaq Evo N110 computer models use configuration code **KFKZ**.

**Table 1-1**  
**Compaq Armada 110 and Evo N110**  
**Models and Model Naming Conventions (*Continued*)**

1	2	3	4	5	6	7	8	9	10	11
The following Compaq Armada 110 computer models use configuration code <b>KFKZ</b> .										
A11	P	850	4X	20	D	C	64	M	L	243859-B21
A11	P	850	4X	20	D	C	64	M	L	243860-B21 (NAFTA)
A11	C	850	4X	20	D	C	64	M	H	258292-B21
A11	C	850	4X	15	D	C	64	M	H	243857-B21
A11	C	850	4X	15	D	C	64	M	H	243858-B21 (Europe)
A11	C	850	2S	15	D	C	64	M	H	243854-B21
A11	C	850	2S	15	D	C	64	M	H	243855-B21 (NAFTA)
A11	C	850	2S	15	D	C	12	M	H	243856-B21

**Table 1-1  
Compaq Armada 110 and Evo N110  
Models and Model Naming Conventions (Continued)**

1	2	3	4	5	6	7	8	9	10	11
The following Compaq Armada 110 computer models use configuration code <b>JMVZ</b> .										
A11	P	800	4X	10	V	C	64	M	L	226917-B21
A11	P	800	4X	10	D	C	64	M	L	226915-B21
A11	P	800	4X	10	D	C	64	M	L	231665-B21 (NAFTA)
A11	P	800	2S	10	D	C	64	M	L	226918-B21
A11	C	700	4X	10	D	C	64	M	L	231664-B21
A11	C	700	4X	10	D	C	64	M	H	226919-B21
A11	C	700	2S	10	D	M	64	8M	H	226921-B21
A11	C	700	2S	10	D	M	64	8M	H	231663-B21 (NAFTA)

## Features

- Processors, varying by computer model:
  - 1.0-GHz or 850- or 800-MHz Intel Pentium III processors, with 256-KB integrated cache, varying by computer model
  - 1.0-GHz or 850- or 700-MHz Intel Celeron processors, with 128-KB integrated cache, varying by computer model
- ATI RAGE LT Pro, 4-MB SGRAM (synchronous graphics)
- 64-MB high-performance Synchronous DRAM (SDRAM), expandable to 320 MB
- Microsoft Windows 98 or Windows Me preinstalled

- Displays, varying by computer model:
  - ❑ 14.1-inch, SXGA, CTFT (1024 × 768) display, with over 16.8 million colors
  - ❑ 12.1-inch, SVGA, CTFT (800 × 600) display, with over 16.8 million colors
- Full-size TouchPad keyboard
- Mini PCI 56K V.90 modem or mini PCI V.90 modem plus 10/100 NIC combination card, varying by computer model
- One Type II PC Card slot with support for both 32-bit CardBus and 16-bit PC Cards
- External AC adapter with power cord
- 9-cell Lithium ion (Li ion) or Nickel Metal Hydride (NiMH) battery pack
- 20- or 10-GB high-capacity hard drive, varying by computer model
- Connectors for:
  - ❑ stereo speaker/headphone
  - ❑ microphone
  - ❑ universal serial bus
  - ❑ RJ-45 network (internal network models only)
  - ❑ RJ-11 modem
  - ❑ keyboard/mouse
  - ❑ AC power
  - ❑ infrared port
- Stereo speakers

## 1.2 Security

If the notebook you are servicing has a password and you know the password, follow these steps to disable or clear the password:

1. Access PhoenixBIOS Setup Utility (PSU) by turning on the computer and pressing **F10** when the Compaq logo displays on the screen.
2. Enter the current password and press **enter**.
3. Move to **Password On Boot**. Use the **+** or **-** key to select **disable** and press **enter**.
4. Move to **Set Supervisor Password**. In the upper space, enter the current password and press **enter**. In the spaces to enter the new password and confirm new password, press **enter**. Press **enter** again to exit the screen.
5. Use the arrow keys to select **Exit** from the menu bar.
6. Make sure **Exit Saving Changes** is selected. Press **enter**, then select **Yes** to save the changes and exit.

If the notebook you are servicing has an unknown password, follow these steps to clear the password. These steps also clear CMOS.

1. Prepare the computer for disassembly. Refer to Section 5.3, “Preparing the Computer for Disassembly,” for more information.
2. Remove the disk cell RTC battery (refer to Section 5.15, “Disk Cell Real Time Clock (RTC) Battery”).
3. Wait approximately five minutes.

4. Reassemble the computer.
5. Connect AC power to the computer. Do **NOT** reinsert the battery pack at this time.
6. Turn on the computer.
7. All passwords and all CMOS settings are clear.

## 1.3 Power Management

The computer operating system provides power management utilities that help maintain and conserve power when the computer is running on battery power.

To access power management options, select the power application icon in the operating system's Control Panel.

### Enabling Power Savings

The Enable Power Savings feature in Power Management controls all power management features. When set to disabled, the power menu is automatically disabled. The default setting is enabled.

### Timeout Settings

Timeout functions can be set up to power down computer components by selecting the Power Schemes tab from the power application in the operating system's Control Panel. When a component such as the monitor, hard drive, system, or video is not in use, the component powers down to conserve power. The time out interval can be set from one minute up to several hours. The component will power up again when you access it or press any key.

## Setting Standby

Standby is initiated by pressing the **Fn+F4** hotkeys or automatically by the computer if it reaches the defined percentage of battery pack power remaining. When Standby is initiated, several subsystems will power off to conserve energy. The system will wake up from Standby when a key is pressed. Although the Standby mode maintains the information and opens the file upon wake-up, any unsaved information is lost if the computer is turned off before ending Standby.

## Hibernation

Hibernation is an energy-saving feature and safeguard that saves information in RAM to a hibernation file on the hard drive, then shuts down the computer. Hibernation is initiated by the computer when the computer reaches the defined percentage of battery pack power remaining. To wake the computer from Hibernation, press the power button. When you resume work, the information returns to the screen where you left off.

The computer uses the operating system with a power management utility that helps you maintain and conserve power when the computer is running on battery power.

## Standby

Standby is an energy-saving feature that conserves power and reduces startup time.

Standby reduces power to system components that are not being used. Standby can be initiated by you or by the system. When Standby is initiated, all work is saved in random access memory (RAM) and the screen is cleared. When work is resumed, the information returns to the screen.

Refer to Section 1.4 in this chapter to identify the Power, Standby, and Hibernation controls.

## 1.4 Computer External Components

The external components on the display and left side of the computer are shown in Figure 1-2 and described in Table 1-2.



**Figure 1–2: Display and Left Side Components**

**Table 1-2  
Display and Left Side Components**

Item	Component	Function
1	Display release latch	Releases the display to open the computer.
2	Infrared port	Links another IrDA-compliant device for wireless communication.
3	Vent	Allows airflow to cool internal components.
4	PC Card slot	Supports 32-bit (CardBus) and 16-bit PC Cards.
5	PC Card eject button	Ejects a PC Card from the PC Card slot.
6	Diskette drive	Accepts 3.5-inch diskettes.



The computer right side and rear panel components are shown in Figure 1-3 and described in Table 1-3.

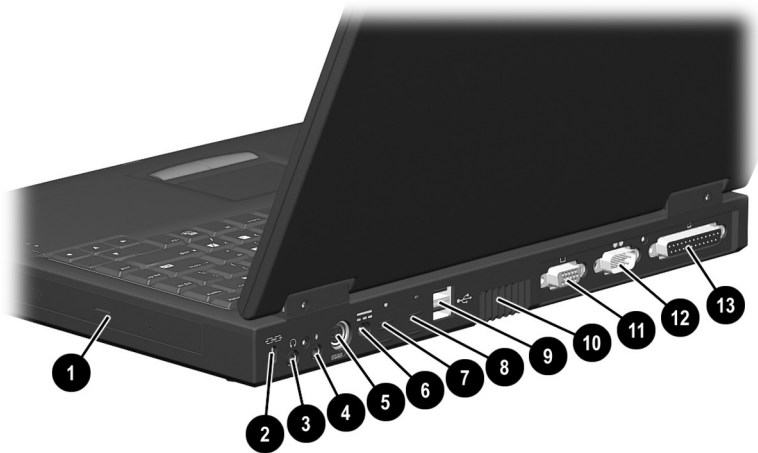

**Figure 1–3: Right Side and Rear Panel Components**

---



**Table 1-3**  
**Right Side and Rear Panel Components**

---

Item	Component	Function
1	Optical drive	Accepts CD- or DVD-ROM disks, depending on the computer model.
2	Security cable slot	Attaches an optional security cable to the computer.
3	Stereo speaker/ headphone jack	Connects stereo speakers, headphones, headset, or television audio.
4	Microphone jack	Connects a single sound channel microphone.

---

**Table 1-3**  
**Right Side and Rear Panel Components (Continued)**

Item	Component	Function
5	Keyboard/mouse connector	Connects an optional full-sized keyboard or a mouse. When this connector is used, both the external and computer keyboard and pointing device are active. An optional splitter/adaptor allows both an external keyboard and mouse to be used at the same time.
6	Power jack	Connects any one of the following: <ul style="list-style-type: none"> <li>■ AC Adapter</li> <li>■ Optional Automobile Power Adapter/Charger</li> <li>■ Optional Aircraft Power Adapter</li> </ul>
7	RJ-11 jack (internal modem models only)	Connects the modem cable to an internal modem.  A modem cable is included with internal modem models.
8	RJ-45 jack (network models only)	Connects the network cable.  A network cable is included with network models.
9	Universal Serial Bus (USB) connector	Connects USB devices.
10	Vent	Allows airflow to cool internal components.
11	Serial connector	Connects a serial device.
12	External monitor connector	Connects an external monitor or overhead projector.
13	Parallel connector	Connects a parallel device.

The computer keyboard components are shown in Figure 1-4 and described in Table 1-4.

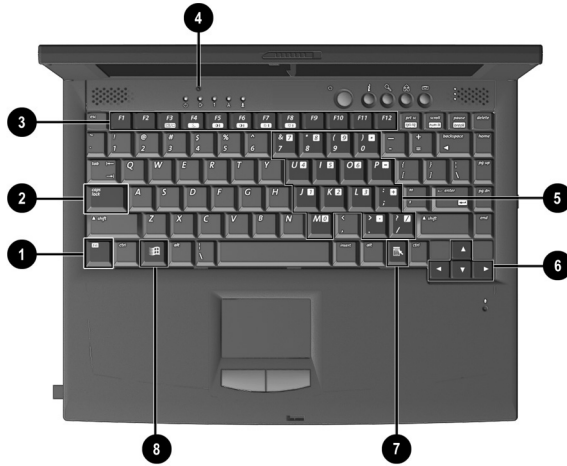

**Figure 1–4: Keyboard Components**

---

**Table 1-4**  
**Keyboard Components**

---

<b>Item</b>	<b>Component</b>	<b>Function</b>
1	<b>Fn</b> key	Used with hotkeys to perform preset hotkey functions.
2	<b>Caps lock</b> key	Turns on the caps lock function.
3	<b>F1</b> through <b>F12</b> function keys	Perform preset functions.
4	Display switch	Turns off the computer display if the computer is closed while on.
5	Embedded numeric keypad	Converts keys to numeric keypad.
6	Cursor control keys	Move the cursor around the screen.
7	Windows application keys	Displays a menu when using a Microsoft application. The menu is the same that is displayed by pressing the right mouse button.
8	Microsoft logo key	Displays Windows Start menu.

---

The components on the top of the computer are shown in Figure 1-5 and described in Table 1-5.

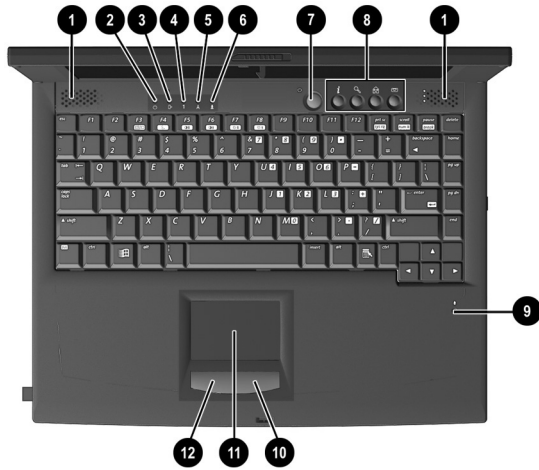

**Figure 1–5: Top Components**

---

**Table 1-5  
Top Components**

---

Item	Component	Function
1	Speakers (2)	Produce stereo sound.
2	Hard drive light	On: The primary hard drive is being accessed.

---

**Table 1-5**  
**Top Components (Continued)**

<b>Item</b>	<b>Component</b>	<b>Function</b>
3	Battery light	Green steady: Battery charging is complete. Red steady: Battery pack is charging. Red blinking: Battery pack is being queried, computer cannot communicate with battery pack, or battery pack is bad.
4	Num lock light	On: <b>Num lock</b> is on and the embedded numeric keypad is enabled.
5	Caps lock light	On: <b>Caps lock</b> is on.
6	Scroll lock light	On: <b>Scroll lock</b> is on.
7	Power button	Turns the computer on or off or exits Standby.
8	Easy Access buttons (4)	Four buttons that provide quick access to the Internet.
9	Microphone	Inputs single-channel sound to the computer; can be used whether the computer is open or closed.
10	Right TouchPad button	Functions like the right mouse button on an external mouse.
11	TouchPad	Moves the mouse cursor, selects, and activates.
12	Left TouchPad button	Functions like the left mouse button on an external mouse.

The external components on the bottom of the computer are shown in Figure 1-6 and described in Table 1-6.

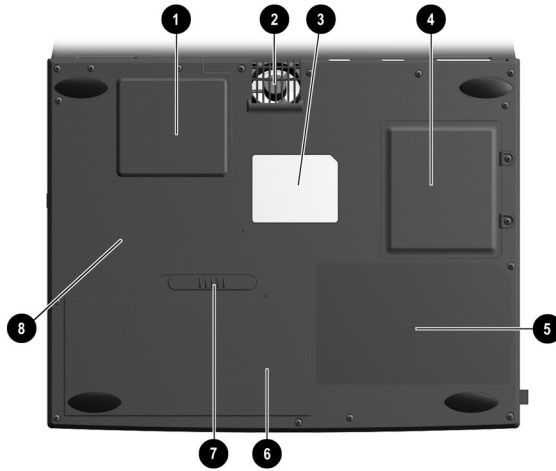

**Figure 1-6: Bottom Components**

**Table 1-6**  
**Bottom Components**

<b>Item</b>	<b>Component</b>	<b>Function</b>
1	Mini PCI slot cover	Contains the mini PCI modem or network interface card.
2	Fan vent	Provides airflow to cool internal components.
3	Certificate of Authenticity label	Contains the Product Key, which may need to be entered before using some Windows operating systems.
4	Memory expansion compartment	Covers the memory expansion compartment.
5	Front label area	Contains agency information.
6	Battery compartment	Accepts a 9-cell Lithium ion (Li ion) or Nickel Metal Hydride (Ni MH) battery pack.
7	Battery release latch	Releases the battery pack from the battery bay.
8	Serial number	Identifies the computer.



## 1.4 Design Overview

This section presents a design overview of key parts and features of the computer. Refer to Chapter 3, “Illustrated Parts Catalog” and Chapter 5, “Removal and Replacement Procedures.”

The system board provides the following device connections:

- Memory expansion board
- Hard drive
- Display
- Keyboard/TouchPad
- Audio
- Intel Pentium III or Intel Celeron Processors
- Fan
- PC Card
- Modem or modem/NIC
- Microphone

The computer uses an electrical fan for ventilation. The fan is controlled by a temperature sensor and is designed to turn on automatically when high temperature conditions exist. These conditions are affected by high external temperatures, system power consumption, power management/battery conservation configurations, battery fast charging, and software applications. Exhaust air is displaced through the ventilation grill located on the right side of the computer.



**CAUTION:** To properly ventilate the computer, allow at least a 3-inch (7.6 cm) clearance on the left and right sides of the computer.

---

---

## Troubleshooting

---



**WARNING:** Only authorized technicians trained by Compaq should repair this equipment. All troubleshooting and repair procedures are detailed to allow only subassembly/module level repair. Because of the complexity of the individual boards and subassemblies, no one should attempt to make repairs at the component level or to make modifications to any printed wiring board. Improper repairs can create a safety hazard. Any indication of component replacement or printed wiring board modification may void any warranty or exchange allowances.

---

Utilities that are preinstalled on the computer include:

- **PhoenixBIOS Setup Utility**—Allows you to modify or restore factory default settings and configure the system BIOS to diagnose and solve minor problems.
- **Power Management**—Allows you to reduce your computer power consumption. Power Management information is contained in Chapter 1.
- **Security**—Allows you to set or remove your power-on password. Security information is contained in Chapter 1.

## Using the PhoenixBIOS Setup Utility

The PhoenixBIOS Setup Utility (PSU) is built into the system. You can configure the system BIOS and modify or restore factory default settings, such as date and time, types of disk drives, power management, and password settings. To run PSU, press **F10** during system startup. When the main screen displays, use the keyboard and arrow keys to move around the menus and make selections.

# Troubleshooting Flowcharts for Portable Computers

**Table 2-1**  
**Troubleshooting Flowcharts Overview**

<b>Section</b>	<b>Description</b>
2.1	Initial troubleshooting
2.2	No power, part 1
2.3	No power, part 2
2.4	No power, part 3
2.5	No power, part 4
2.6	No video, part 1
2.7	No video, part 2
2.8	Non-functioning docking station
2.9	No operating system (OS) loading
2.10	No OS loading from hard drive, part 1
2.11	No OS loading from hard drive, part 2
2.12	No OS loading from hard drive, part 3
2.13	No OS loading from diskette drive
2.14	No OS loading from CD-/DVD-ROM drive
2.15	No audio, part 1
2.16	No audio, part 2
2.17	Non-functioning device
2.18	Non-functioning keyboard
2.19	Non-functioning pointing device
2.20	No network or modem connection

## 2.1 Initial Troubleshooting

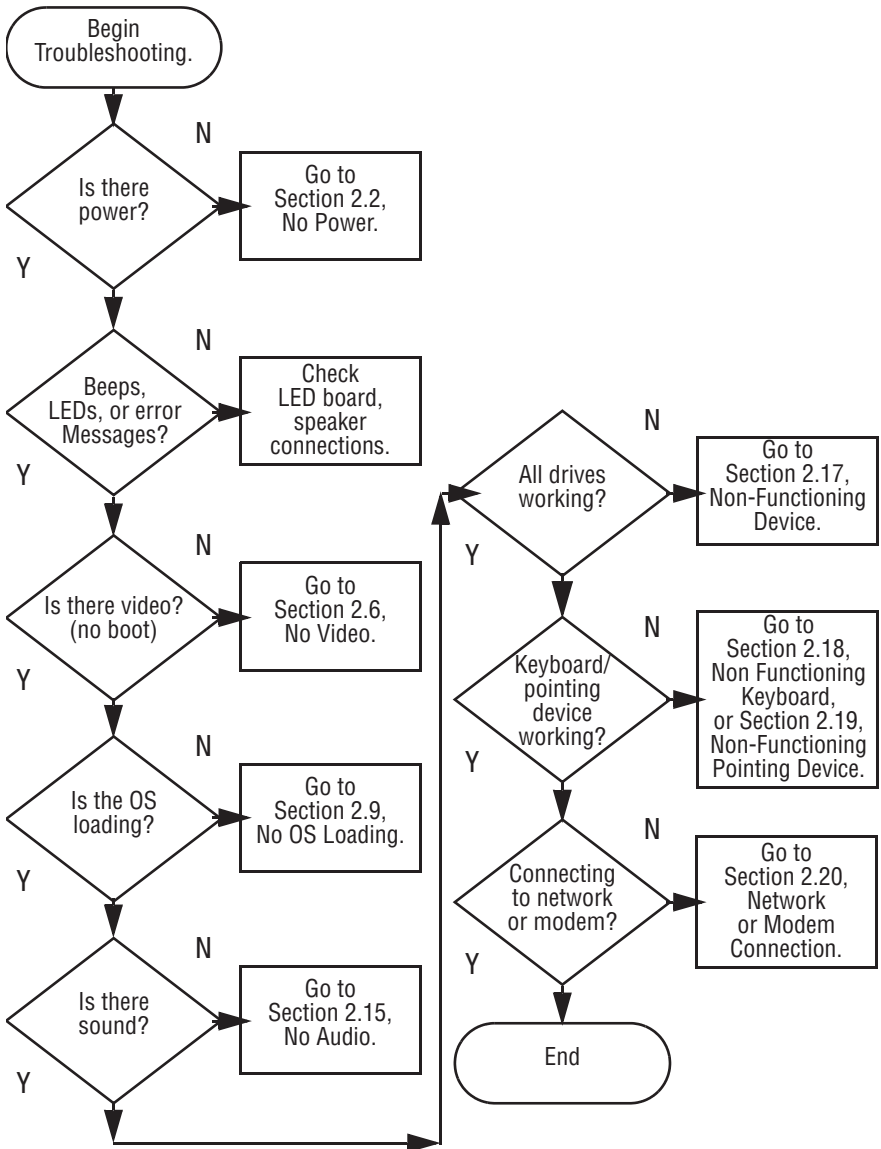

## 2.2 No Power, Part 1

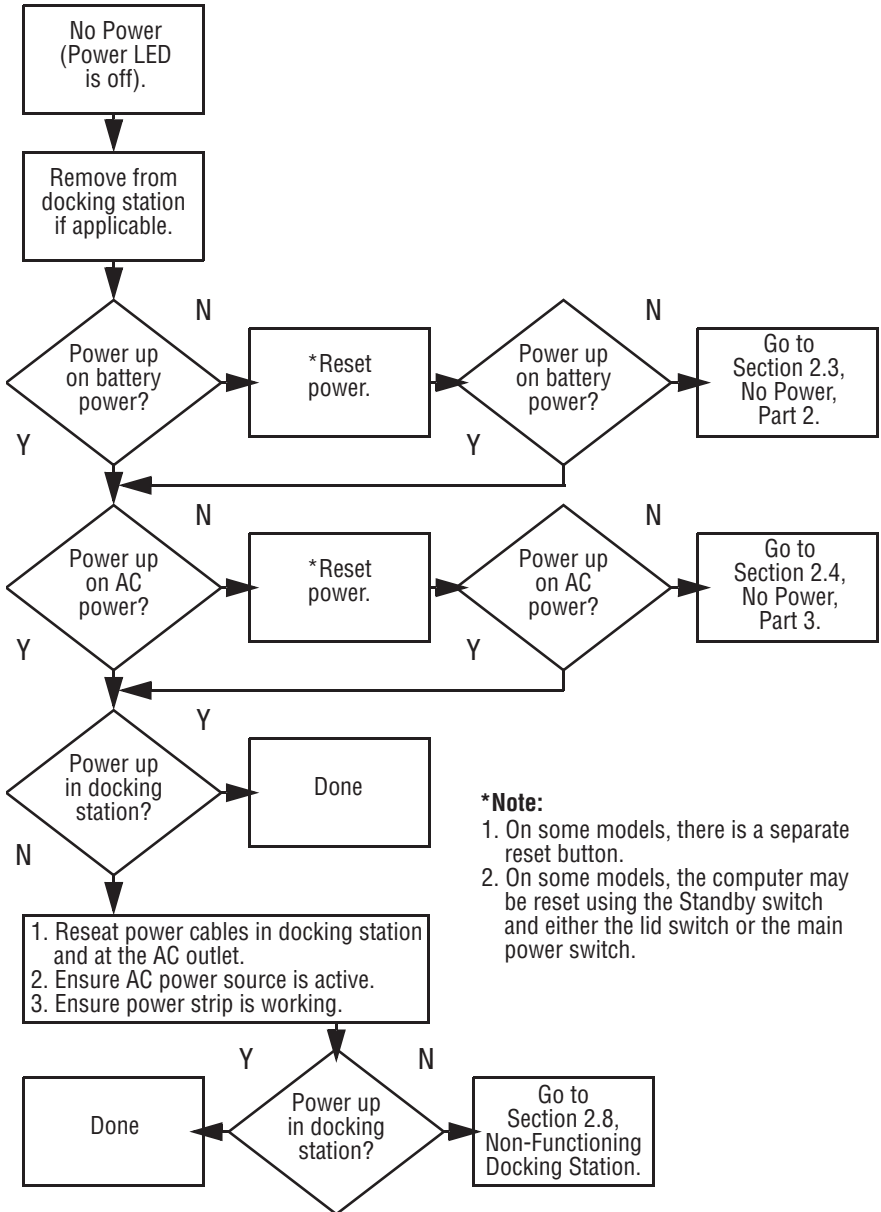

- \*Note:**
1. On some models, there is a separate reset button.
  2. On some models, the computer may be reset using the Standby switch and either the lid switch or the main power switch.

## 2.3 No Power, Part 2

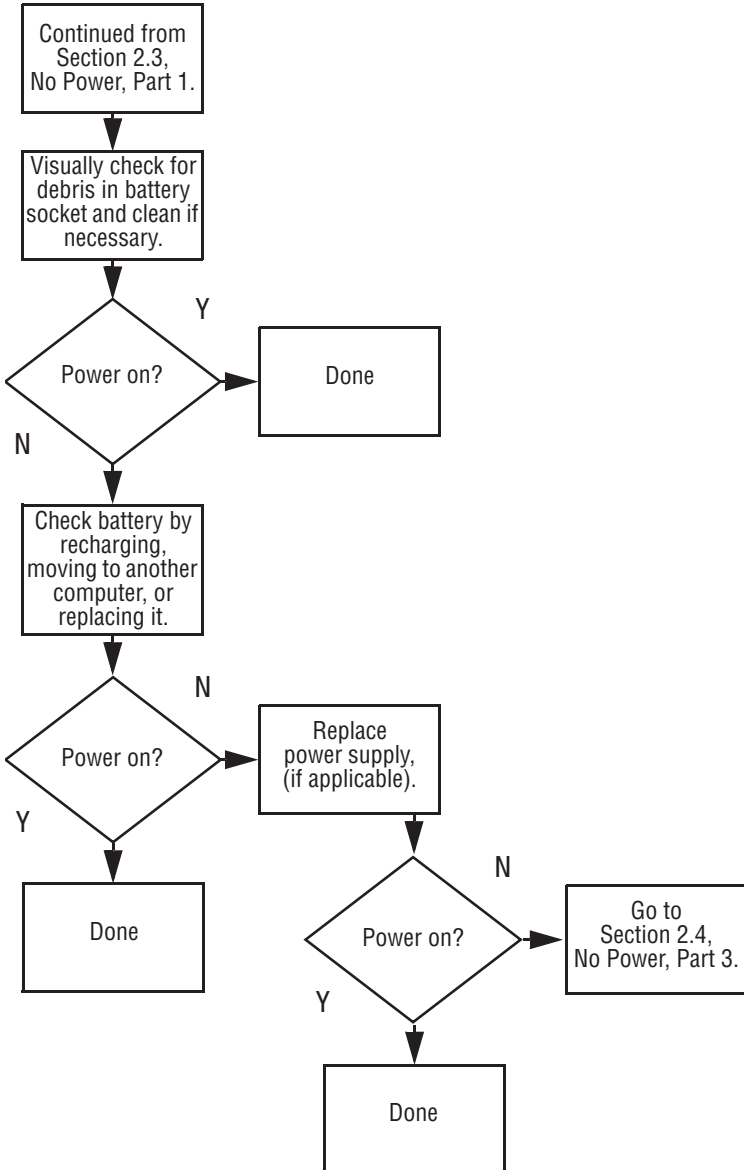

## 2.4 No Power, Part 3

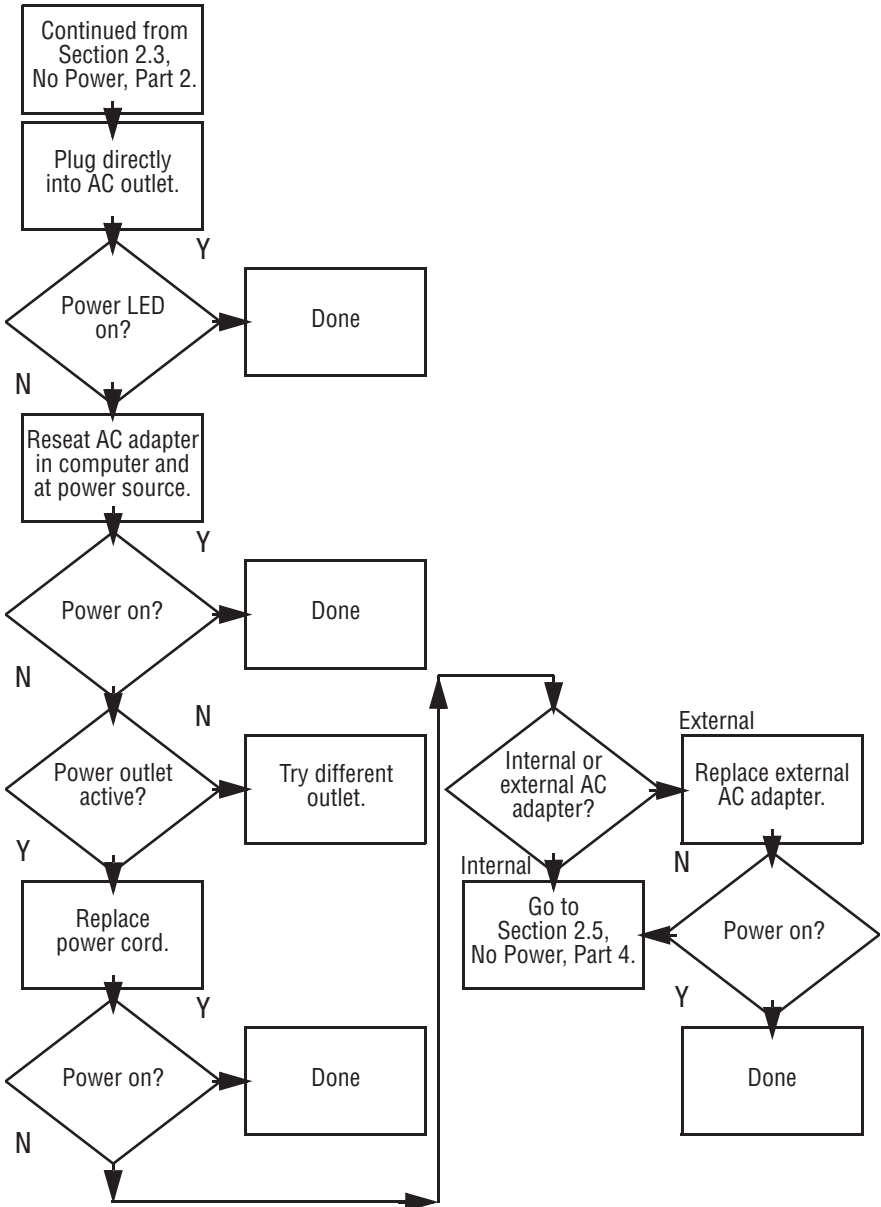



## 2.5 No Power, Part 4

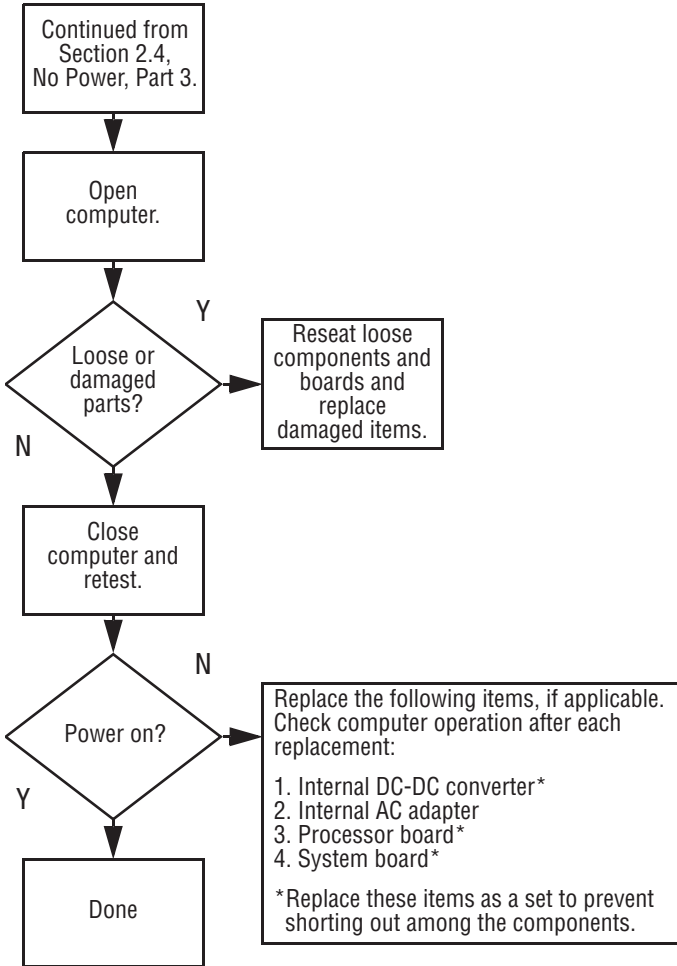

## 2.6 No Video, Part 1

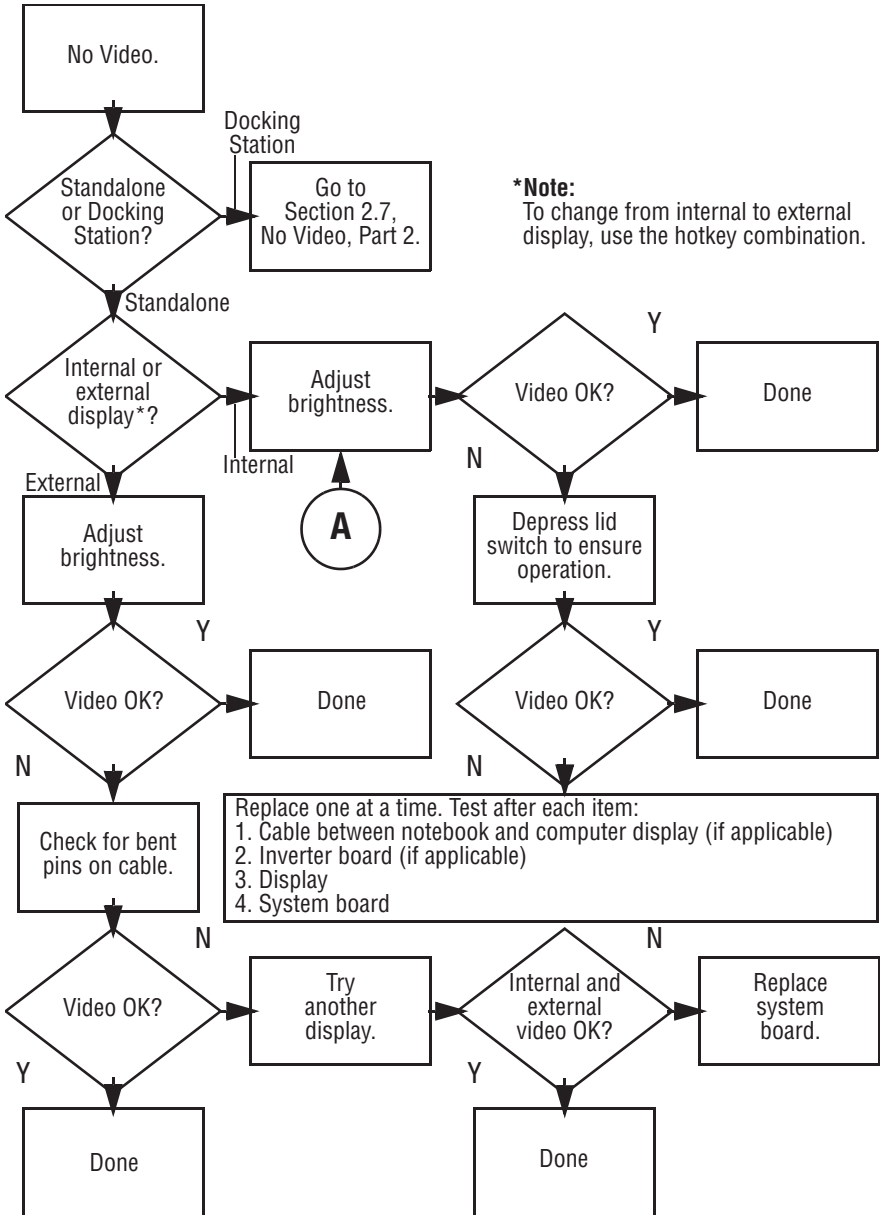

## 2.7 No Video, Part 2

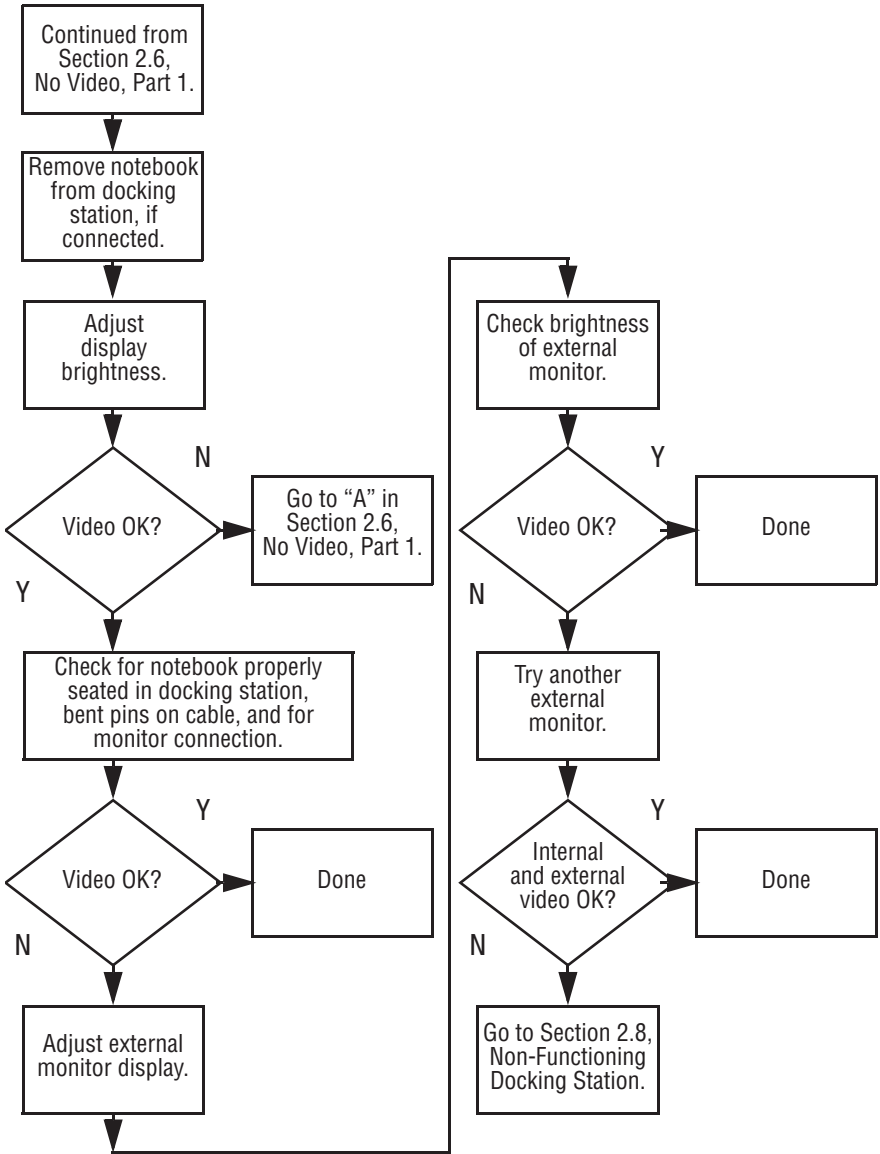

## 2.8 Non-Functioning Docking Station (if applicable)

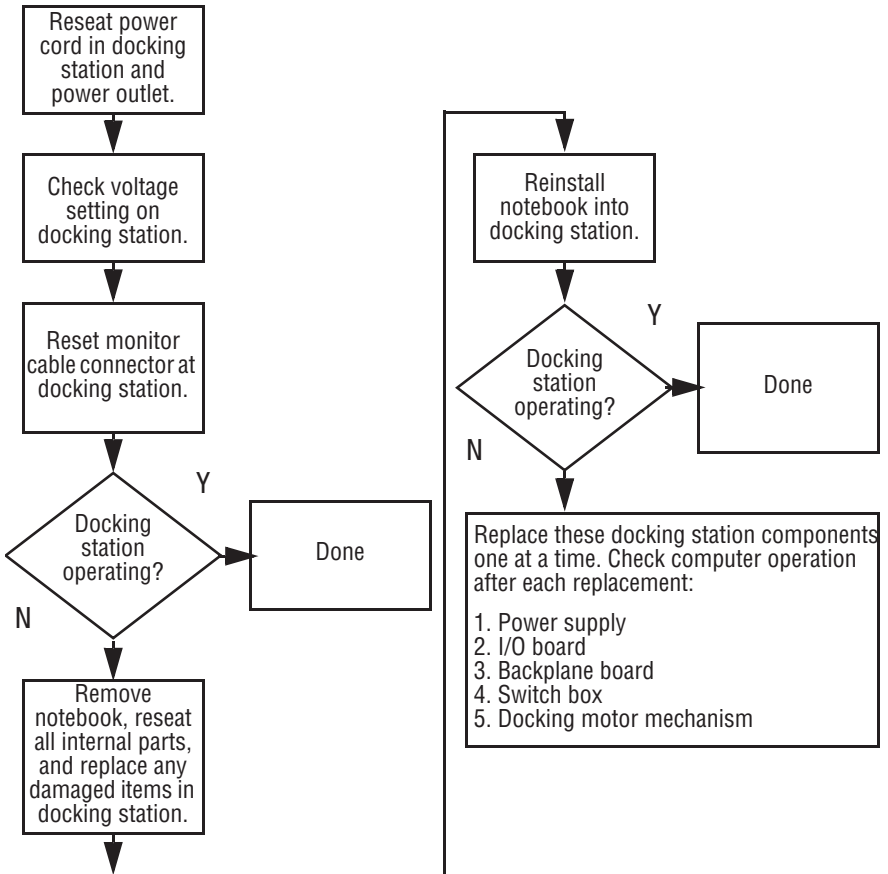

## 2.9 No Operating System (OS) Loading

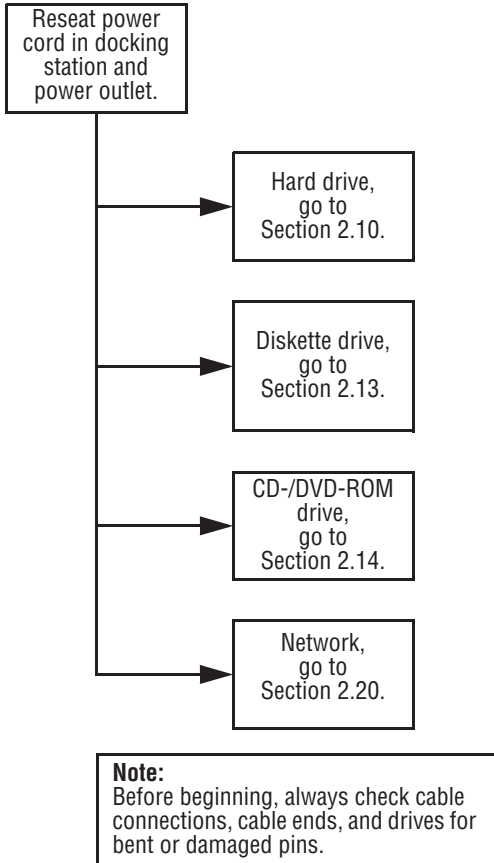

## 2.10 No OS Loading from Hard Drive, Part 1

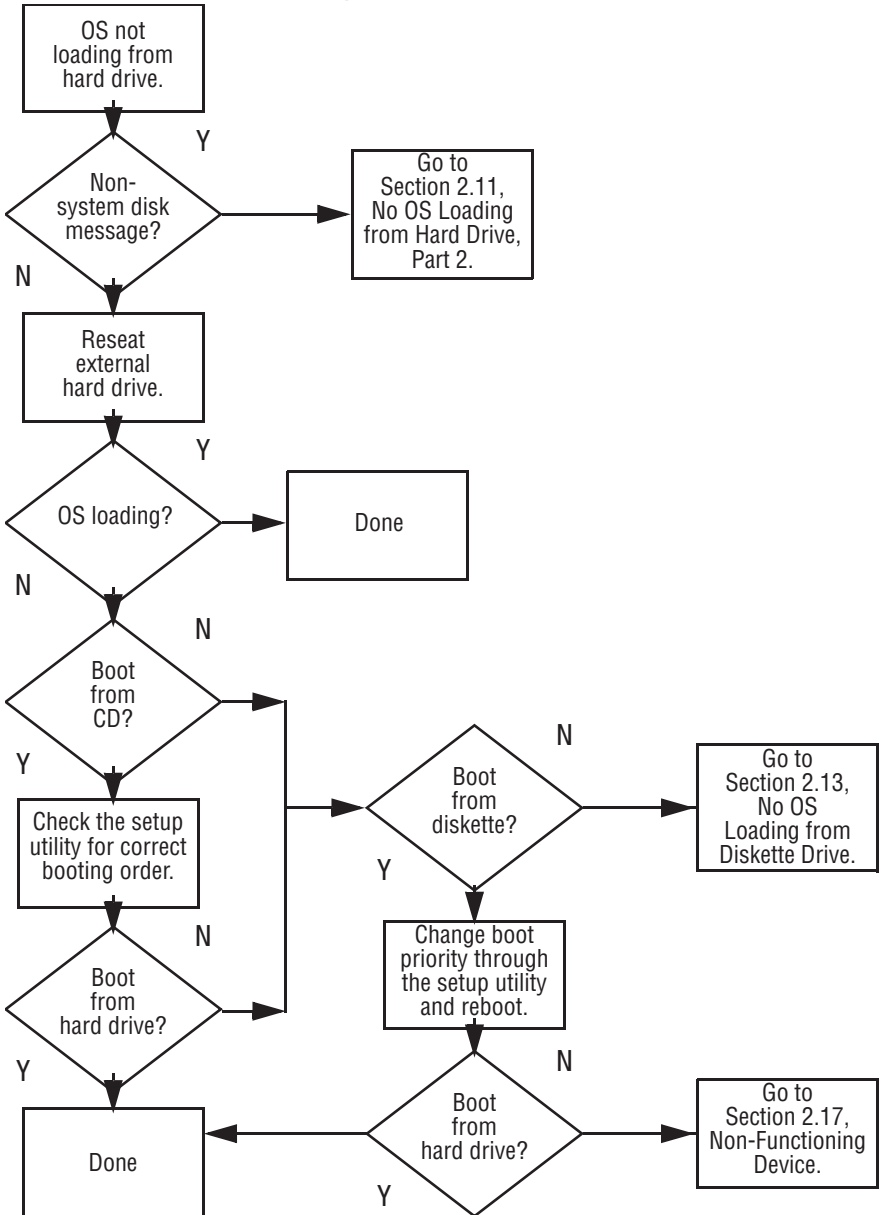

## 2.11 No OS Loading from Hard Drive, Part 2

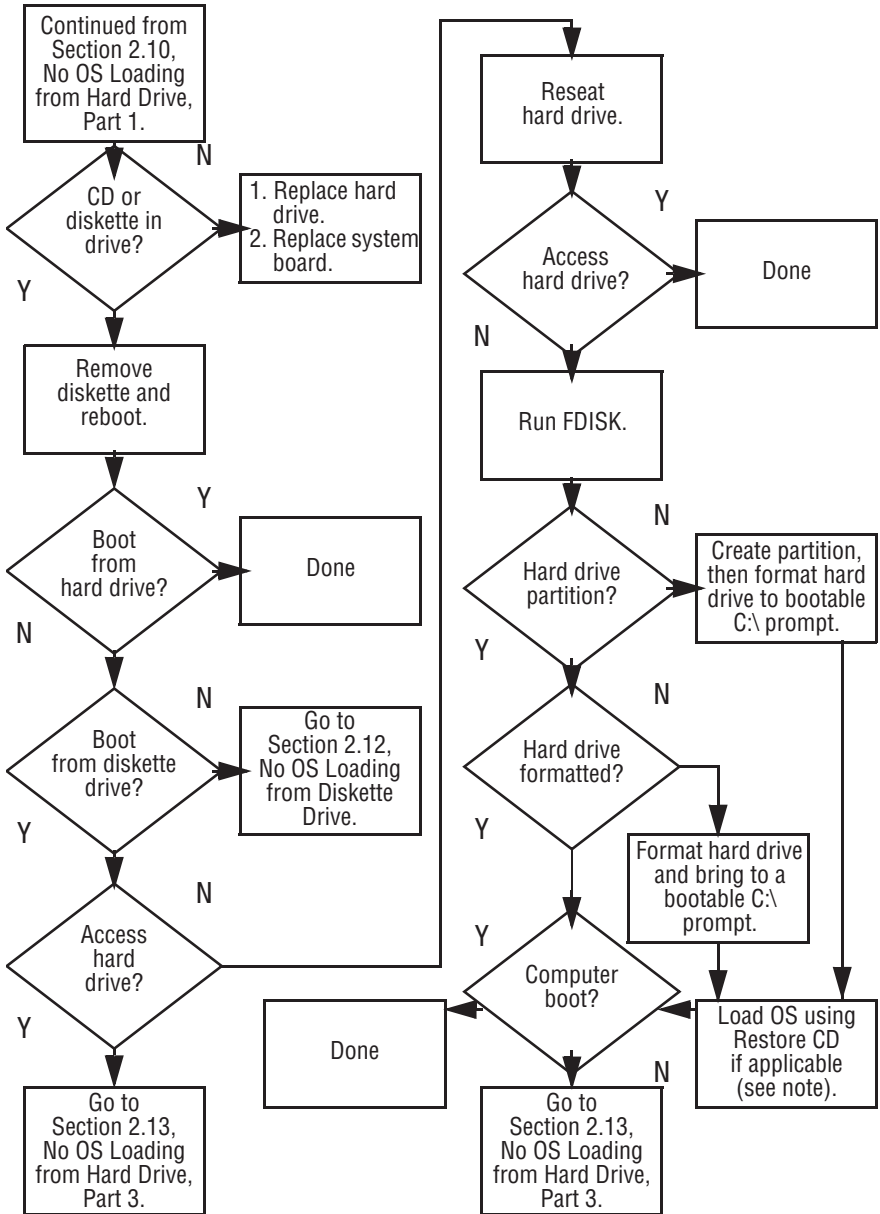

## 2.12 No OS Loading from Hard Drive, Part 3

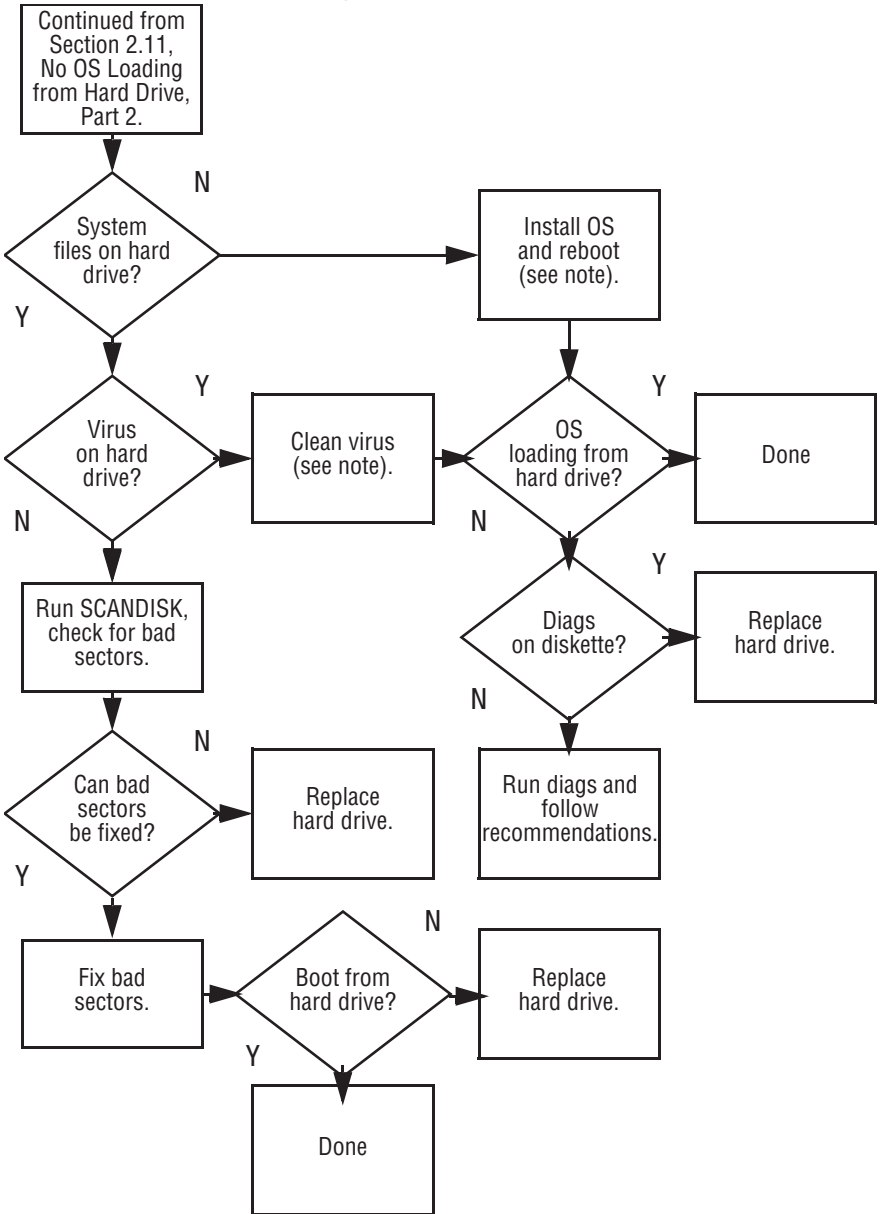



## 2.13 No OS Loading from Diskette Drive

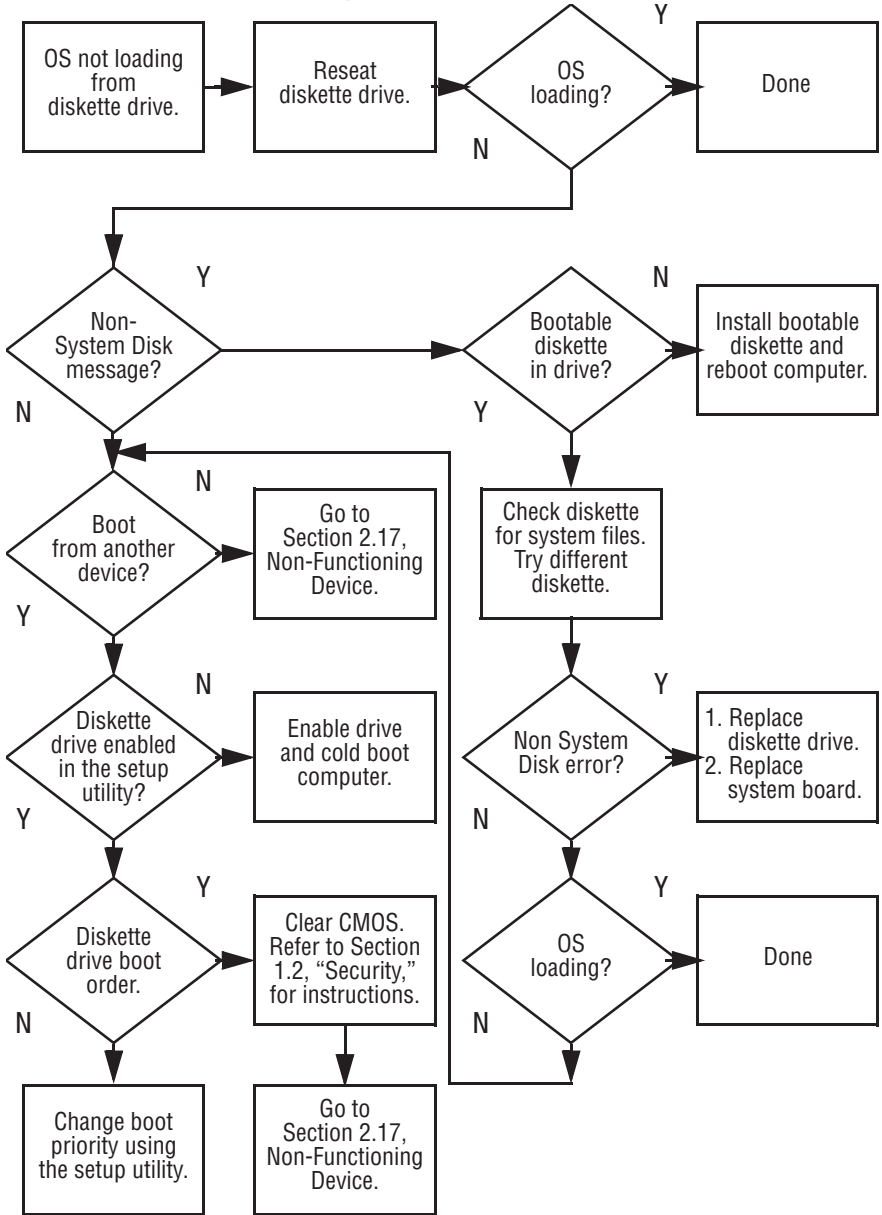

## 2.14 No OS Loading from CD- or DVD-ROM Drive

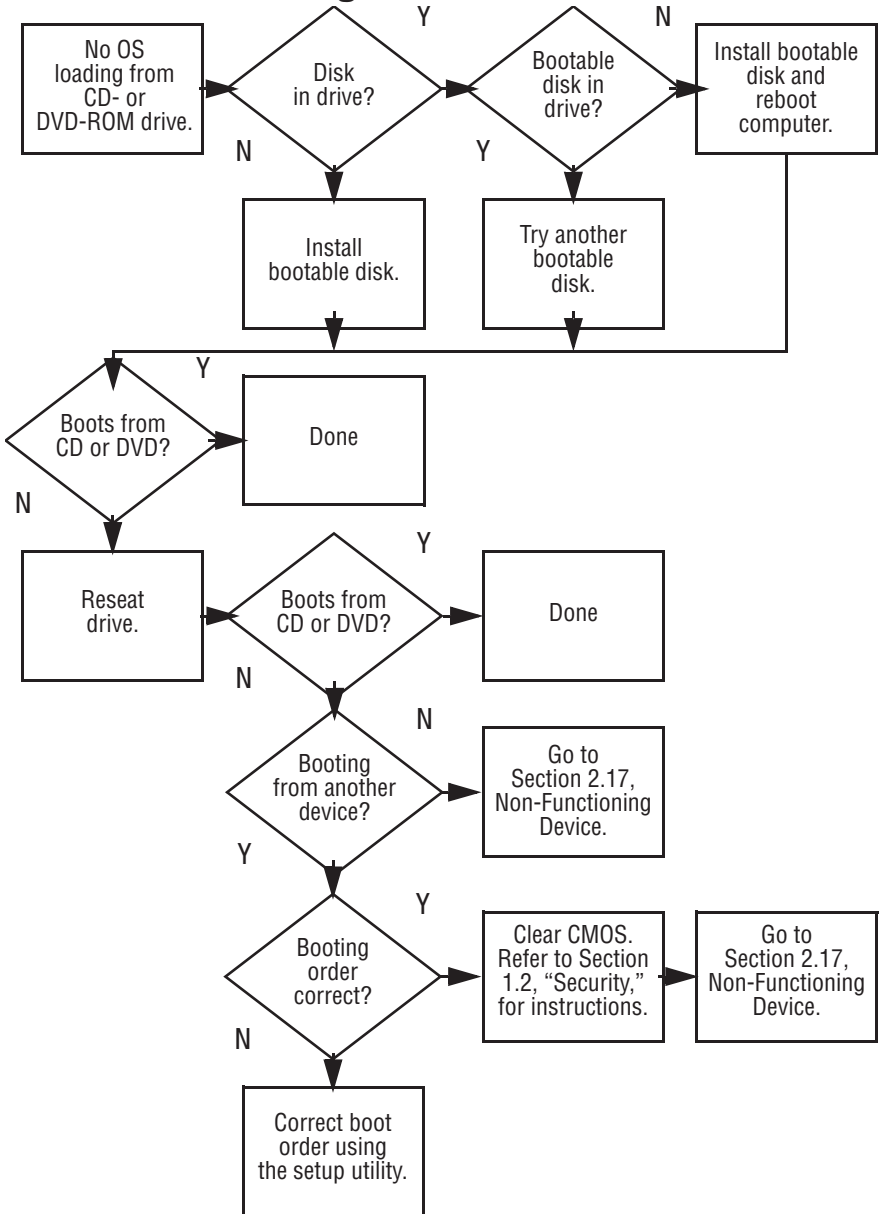

## 2.15 No Audio, Part 1

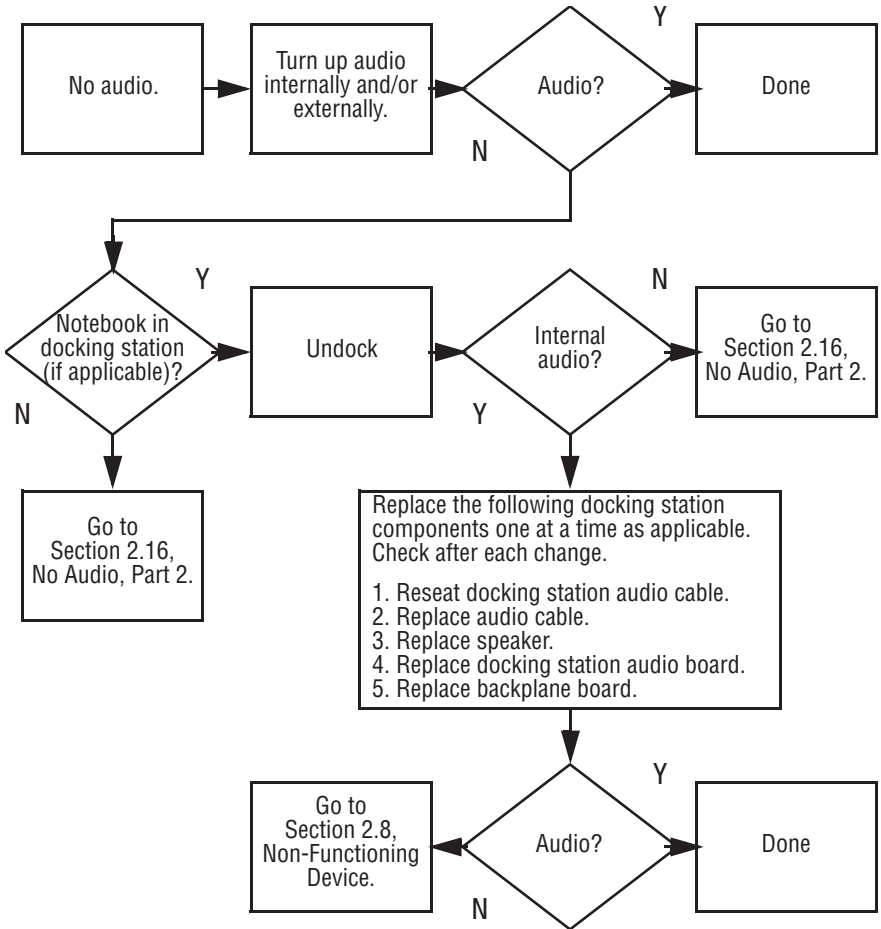

## 2.16 No Audio, Part 2

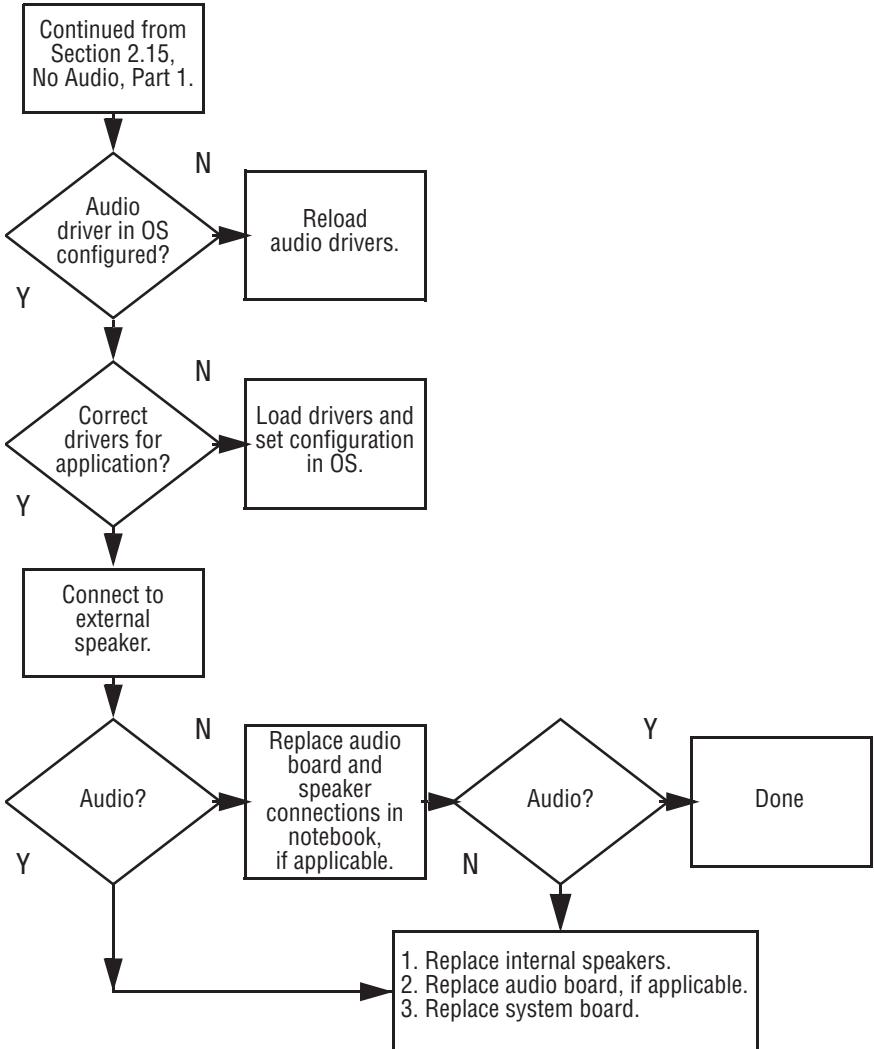

## 2.17 Non-Functioning Device

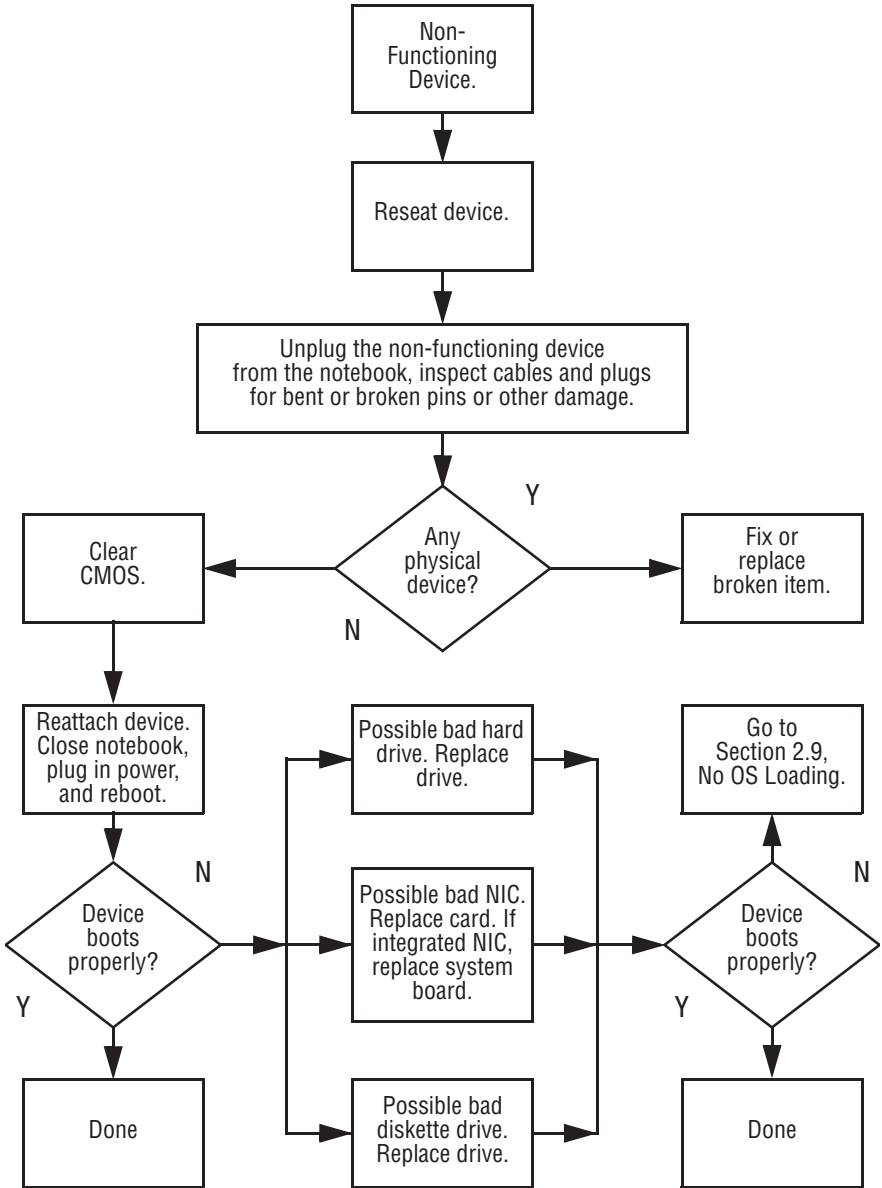

## 2.18 Non-Functioning Keyboard

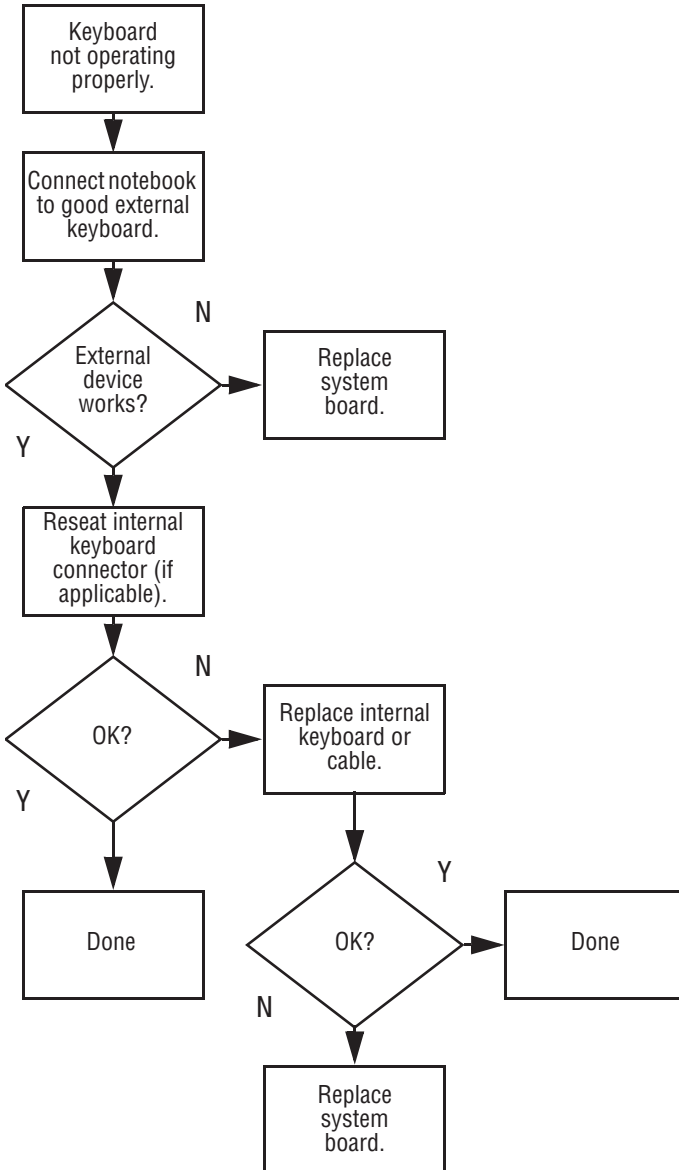

## 2.19 Non-Functioning Pointing Device

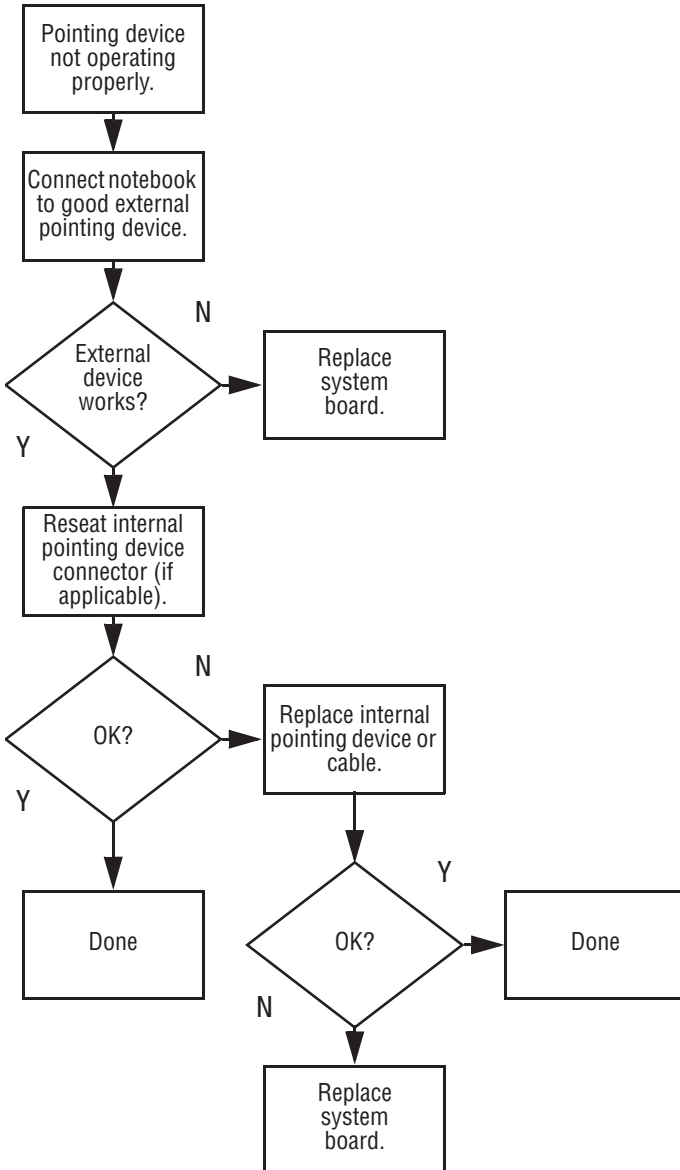

## 2.20 Network or Modem Connection

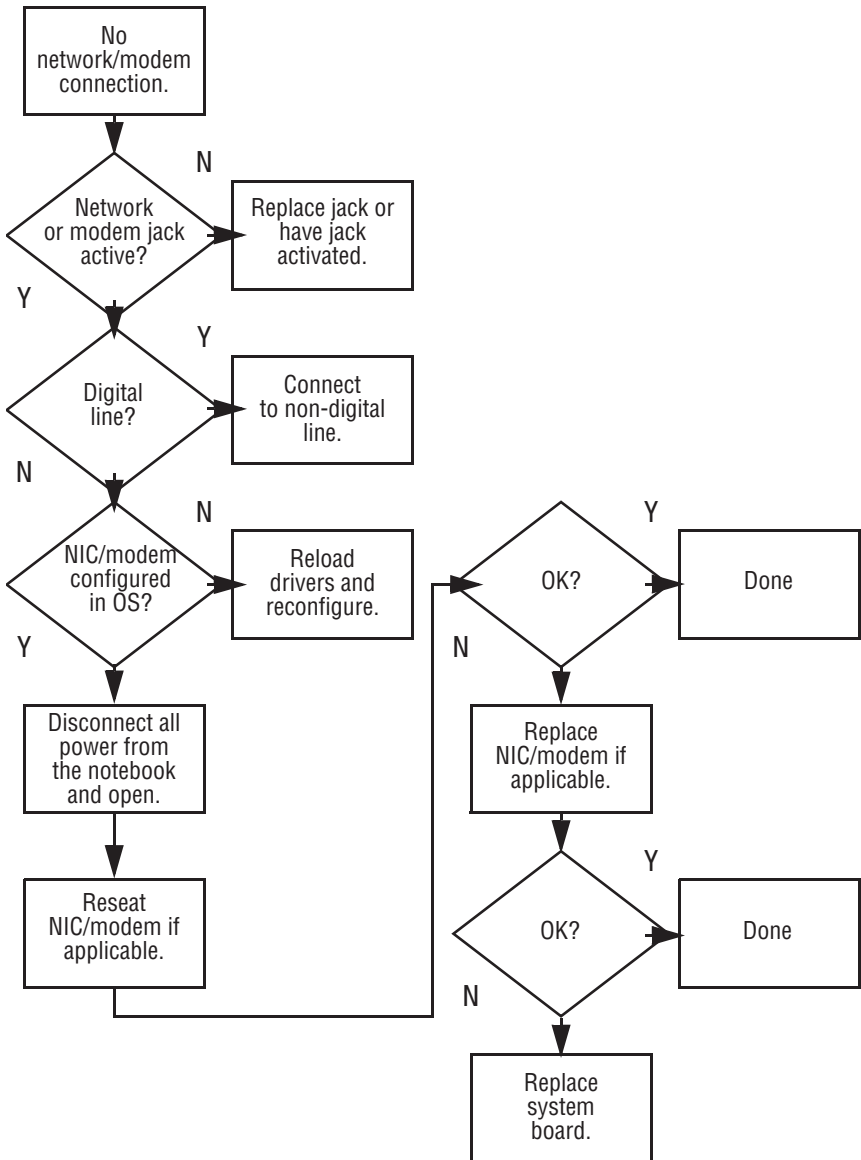



---

## Illustrated Parts Catalog

This chapter provides an illustrated parts breakdown and a reference for spare part numbers and option part numbers.

### 3.1 Serial Number Location

When ordering parts or requesting information, provide the computer serial number and model number located on the bottom of the computer (Figure 3-1).

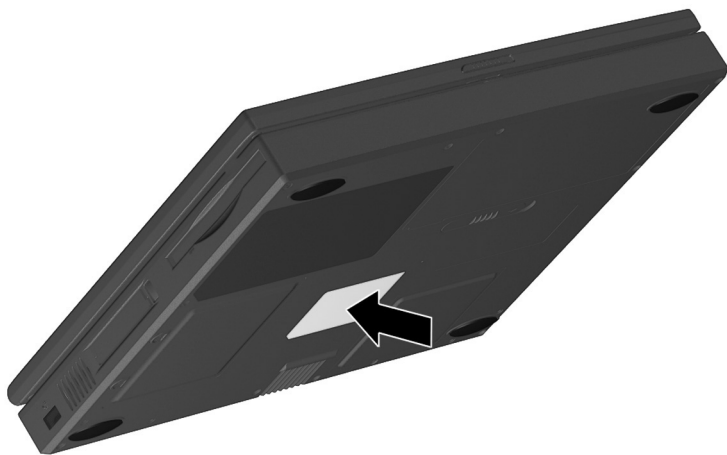

**Figure 3–1: Serial Number Location**

## 3.2 Computer System Major Components

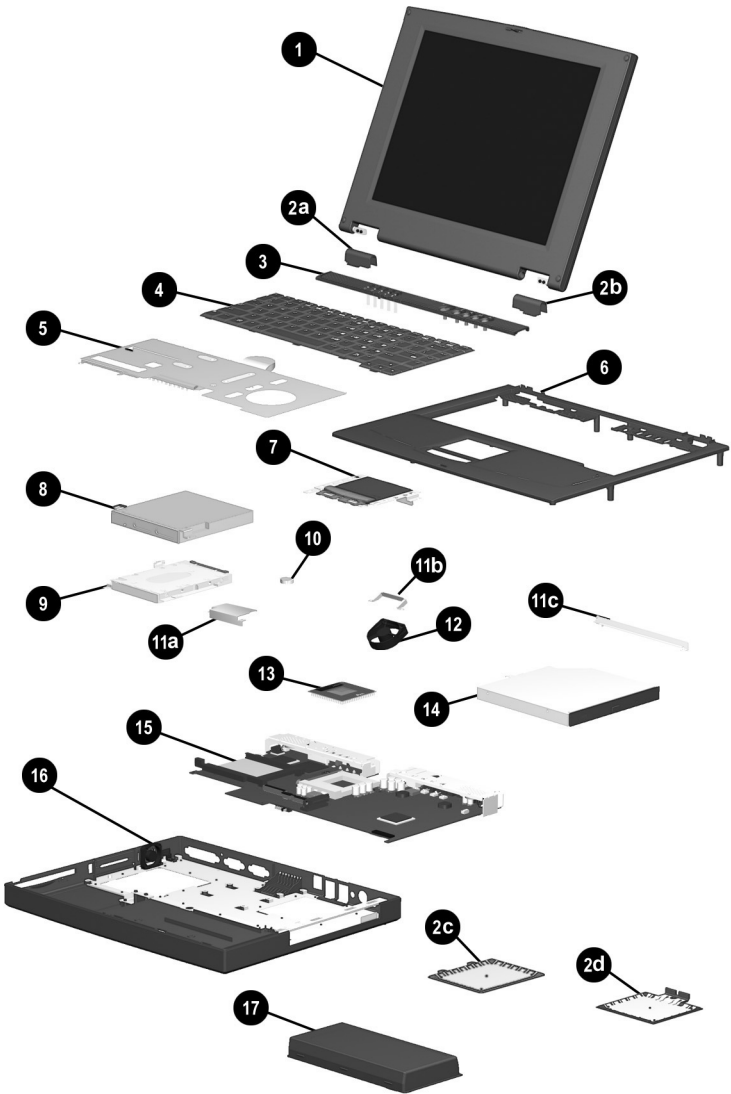
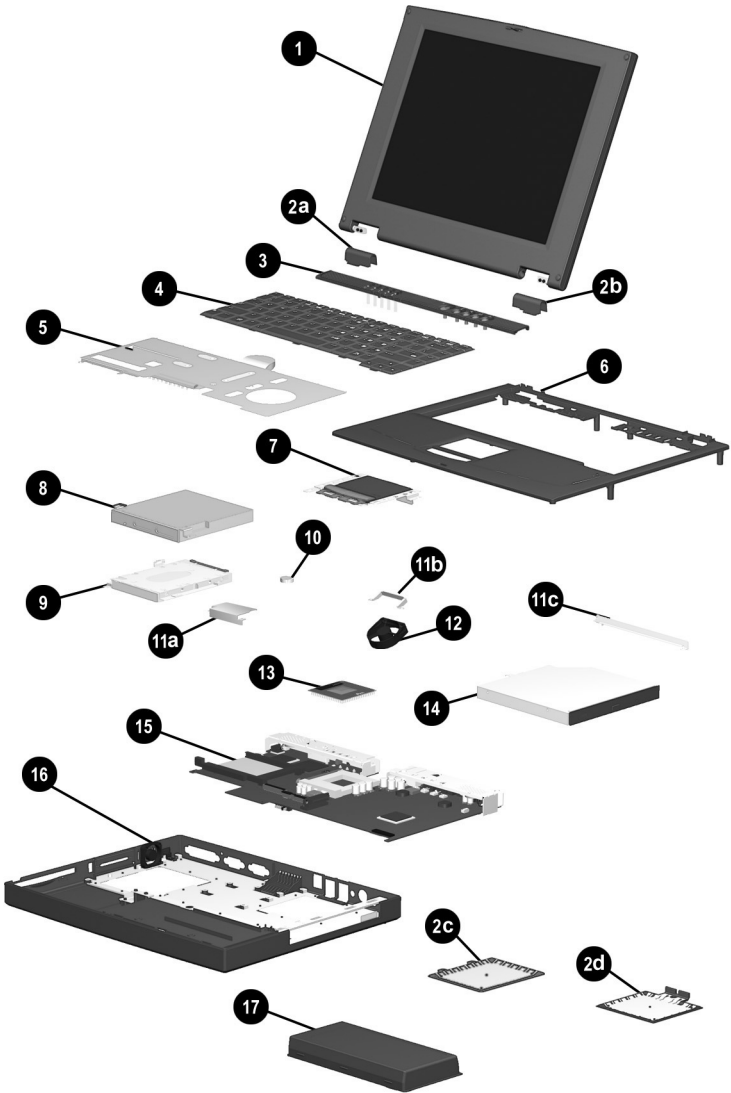

Figure 3-2: Computer System Major Components

**Table 3-1**  
**Spare Parts: Computer System Major Components**

<b>Item</b>	<b>Description</b>	<b>Spare Part Number</b>		
1	<b>Displays</b>			
	14.1-inch, XGA, CTFT (used only with computer models with 1.0-GHz processors)	269909-001		
	14.1-inch, XGA, CTFT (used only with computer models with 850-, 800-, and 700-MHz processors)	233545-001		
	12.1-inch, SVGA, CTFT (used only with computer models with 850-, 800-, and 700-MHz processors)	233544-001		
	<b>Plastics Kit</b>	233562-001		
2a	Left hinge cover	not illustrated: Computer feet RJ-45 cover RJ-11 cover		
2b	Right hinge cover			
2c	Memory expansion compartment cover			
2d	Mini PCI slot cover			
3	<b>LED cover</b>	233559-001		
4	<b>Keyboard</b>			
	Arabic	233740-171	Korean	233740-AD1
	Belgian	233740-381	Latin American	
	Czech	233740-221	Spanish	233740-161
	Danish	233740-081	Norwegian	233740-091
	French	233740-051	Portuguese	233740-131
	French		Russian	233740-251
	Canadian	233740-121	Spanish	233740-071
	German	233740-041	Swedish	233740-101
	Hebrew	233740-BB1	Swiss	233740-BF1
	Hungarian	233740-211	Taiwanese	233740-AB1
	International	233740-002	Turkish	233740-141
	Italian	233740-061	U.K. English	233740-031
	Japanese	233740-291	U.S. English	233740-001



**Computer System Major Components (continued)**

**Table 3-1**  
**Spare Parts: Computer System Major Components (Continued)**

<b>Item</b>	<b>Description</b>	<b>Spare Part Number</b>
5	<b>Heat sink</b> (used only with computer models with 1.0-GHz processors)	269863-001
	<b>Heat sink</b> (used only with computer models with 850-, 800-, and 700-MHz processors)	233555-001
	When replacing the heat sink, you must install a new thermal pad. Refer to Section 5.9, "Heat Sink," for instructions on thermal pad installation.	
6	<b>Top cover</b>	233568-001
7	<b>TouchPad</b>	236076-001
8	<b>Diskette drive</b>	233553-001
9	<b>Hard drives</b>	
	20 GB	253596-001
	15 GB	253595-001
	10 GB	233554-001
	(hard drive bracket spared in Hardware Kit, spare part number 234005-001)	
10	<b>Disk cell RTC battery</b>	236359-001
	<b>Hardware Kit</b>	234005-001
11a	Hard drive bracket	
11b	Fan bracket	
11c	Optical drive alignment rail	
12	<b>Fan</b> (fan bracket spared in Hardware Kit, item 11, spare part number 234005-001)	233552-001

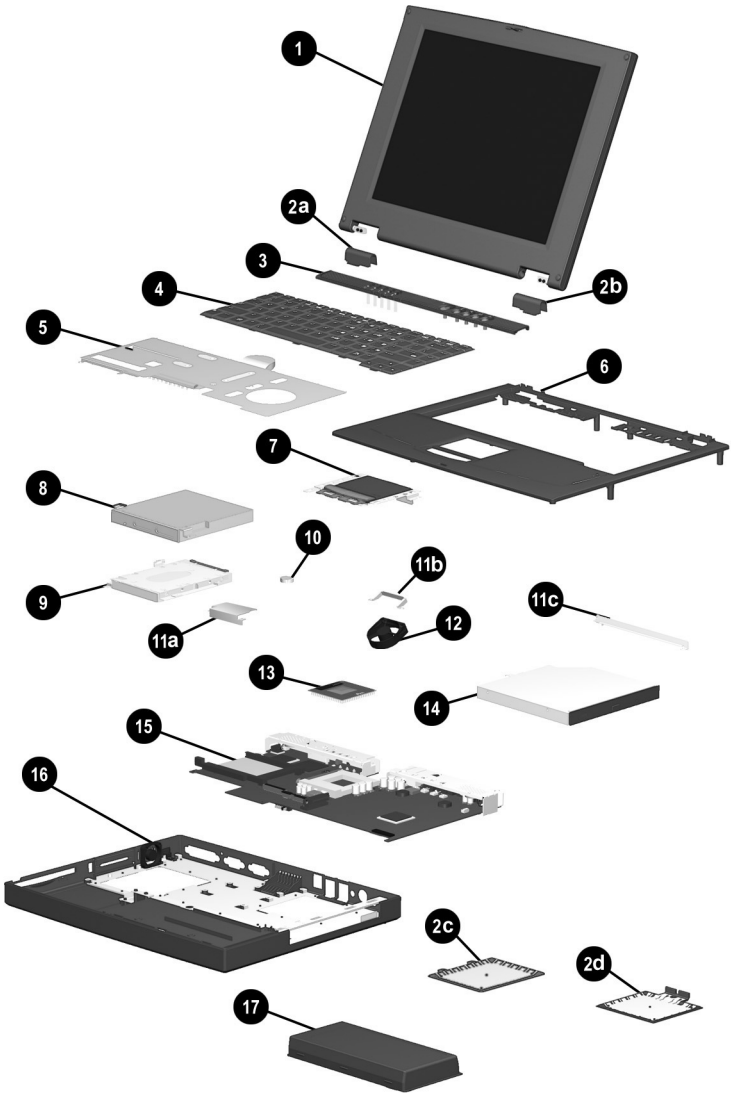

**Computer System Major Components (continued)**

**Table 3-1**  
**Spare Parts: Computer System Major Components (Continued)**

<b>Item</b>	<b>Description</b>	<b>Spare Part Number</b>
13	<b>Processors</b>	
	1.0 GHz Intel Pentium III	269861-001
	1.0 GHz Intel Celeron	269862-001
	850 MHz Intel Pentium III	253593-001
	850 MHz Intel Celeron	253594-001
	800 MHz Intel Pentium III	233551-001
	700 MHz Intel Celeron	233549-001
14	<b>Optical drives</b> (optical drive alignment rail spared in Hardware kit, item 11, spare part number 234005-001)	
	24X Max CD-ROM drive	233550-001
	8X Max DVD-ROM drive	233548-001
15	<b>System board</b> (includes 64 MB SDRAM, left and right speakers, and left and right brackets)	233567-001
16	<b>Base enclosure</b>	233547-001
17	<b>Battery packs</b>	
	9 cell Lithium ion (Li ion)	231964-001
	9 cell Nickel Metal Hydride (Ni MH)	231965-001

### 3.3 Plastics Kit Components

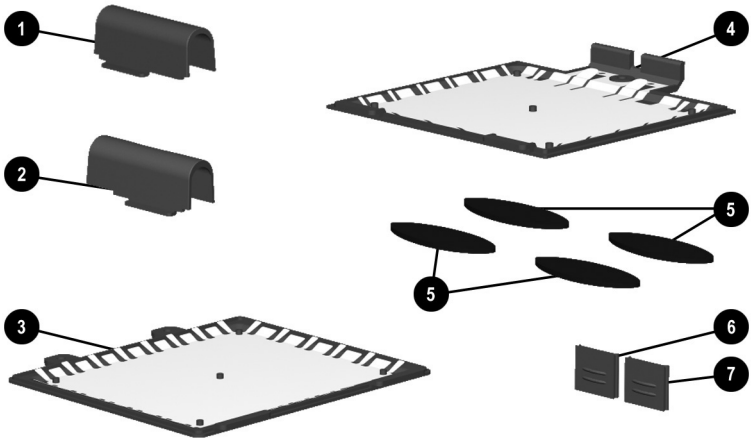

Figure 3-3: Plastics Kit Components

Table 3-2  
Plastics Kit Components  
Spare Part Number 233562-001

Item	Description
1	Left hinge cover
2	Right hinge cover
3	Memory expansion compartment cover
4	Mini PCI slot cover
5	Computer feet
6	RJ-45 cover
7	RJ-11 cover



### 3.4 Hardware Kit Components

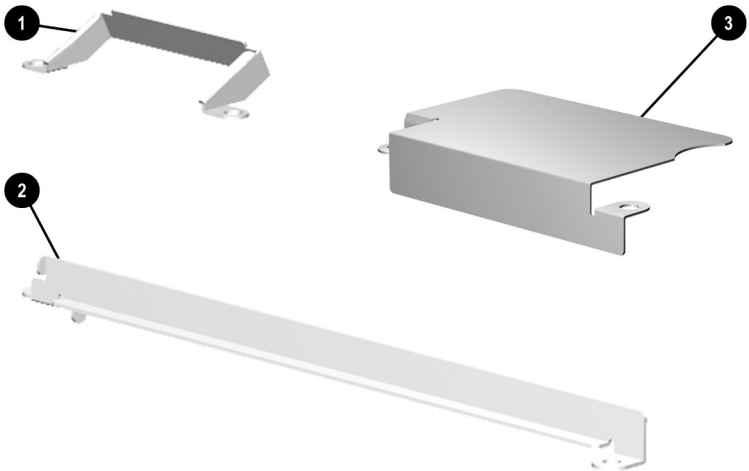
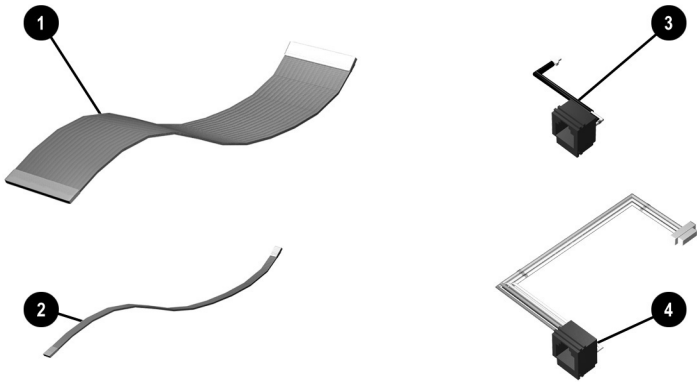

**Figure 3-4: Hardware Kit Components**

**Table 3-3  
Hardware Kit Components  
Spare Part Number 234005-001**

Item	Description
1	Fan bracket
2	Optical drive alignment rail
3	Hard drive bracket

### 3.5 Cable Kit Components



**Figure 3–5: Cable Kit Components**

---

**Table 3-4**  
**Cable Kit Components**  
**Spare Part Number 234006-001**

---

Item	Description
1	Diskette drive cable (2)
2	TouchPad cable
3	RJ-11 cable
4	RJ-45 cable

---

## 3.6 Mass Storage Devices

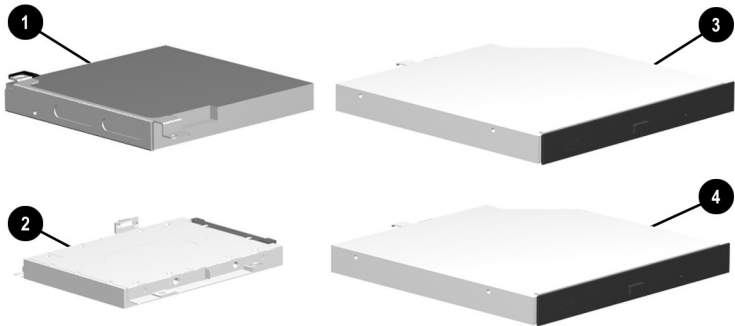

**Figure 3-6: Mass Storage Devices**

**Table 3-5  
Mass Storage Devices**

Item	Description	Spare Part Number
1	Diskette drive	233553-001
2	Hard drives	
	20 GB	253596-001
	15 GB	253595-001
	10 GB	233554-001
	(hard drive bracket spared in Hardware Kit, spare part number 234005-001)	
3	24X Max CD-ROM drive	233550-001
4	8X Max DVD-ROM drive	233548-001

## 3.7 Miscellaneous

**Table 3-6**  
**Spare Parts: Miscellaneous (not illustrated)**

Description			Spare Part Number
<b>Communication boards</b>			
Type III mini PCI combination 56 Kbps modem/network interface card (NIC)			233558-001
Type III mini PCI 56 Kbps modem board			233557-001
PC Card modem			233564-001
<b>Modem adapters</b>			
Czech	234963-221	Norwegian	234963-091
German	236432-041	Swiss	198294-111
Hungarian	234963-211		
<b>Modem cable</b>			234962-001
<b>Modem cable adapters</b>			
Australian			304398-011
Belgian			304398-181
French			304398-051
<b>RJ-11 P55 adapters</b>			
Danish	316904-081	Italian	316904-061
Finnish	316904-351	Swedish	316904-101
<b>RJ-11 PTT adapter</b> (used in the United Kingdom)			158593-031
<b>RJ-45 network cable</b>			237672-001

**Table 3-6**  
**Spare Parts: Miscellaneous (not illustrated) (Continued)**

Description	Spare Part Number
<b>External AC adapter</b>	163444-001
<b>50W slim AC adapter</b>	163444-291
<b>Logo kit</b>	233556-001
<b>Memory expansion boards</b>	
128 MB at 133 MHz	212682-001
64 MB at 133 MHz	212681-001
256 MB at 100 MHz	167136-001
128 MB at 100 MHz	135244-001
64 MB at 100 MHz	135243-001
<b>Screw kit</b> (includes M2.5 × 7, M2.5 × 5.5, M2.5 × 5, and M2.5 × 4.5 screws; refer to Appendix C, "Screw Listing," for more information on screw specifications and usage)	233565-001
<b>Power cord, black, 6 feet</b>	
Australian	246959-011
Danish	246959-081
European/Middle Eastern/African	246959-021
Italian	213352-001
Japanese	197233-001
Korean	246959-AD1
Swiss	246959-AG1
Taiwanese	234961-AA1
U.K. English	246959-031
U.S. English	246959-001

---

# Removal and Replacement Preliminaries

This chapter provides essential information for proper and safe removal and replacement service.

## 4.1 Tools Required

You will need the following tools to complete the removal and replacement procedures:

- Magnetic screwdriver
- Phillips P0 screwdriver
- Tool kit (includes connector removal tool, loopback plugs, and case utility tool)

## 4.2 Service Considerations

Listed below are some of the considerations that you should keep in mind during disassembly and assembly procedures.



As you remove each subassembly from the computer, place it (and all accompanying screws) away from the work area to prevent damage.

---

## Plastic Parts

Using excessive force during disassembly and reassembly can damage plastic parts. Use care when handling the plastic parts. Apply pressure only at the points designated in the maintenance instructions.

## Cables and Connectors

Cables must be handled with extreme care to avoid damage. Apply only the tension required to unseat or seat the cables during removal and insertion. Handle cables by the connector whenever possible. In all cases, avoid bending, twisting, or tearing cables. Ensure that cables are routed in such a way that they cannot be caught or snagged by parts being removed or replaced. Handle flex cables with extreme care; they tear easily.



**CAUTION:** When servicing the computer, ensure that cables are placed in their proper location during the reassembly process. Improper cable placement can damage the computer.

---

## 4.3 Preventing Damage to Removable Drives

Removable drives are fragile components that must be handled with care. To prevent damage to the computer, damage to a removable drive, or loss of information, observe these precautions:

- Before removing or inserting a hard drive, shut down the computer. If you are unsure whether the computer is off or in Hibernation, turn the computer on, then shut it down.
- Before removing a diskette drive or optical drive, ensure that a diskette or disc is not in the drive. Ensure that the optical drive tray is closed.

- Before handling a drive, ensure that you are discharged of static electricity. While handling a drive, avoid touching the connector.
- Handle drives on surfaces that have at least one inch of shock-proof foam.
- Avoid dropping drives from any height onto any surface.
- After removing a hard drive, CD-ROM drive, or a diskette drive, place it into a static-proof bag.
- Avoid exposing a hard drive to products that have magnetic fields such as monitors or speakers.
- Avoid exposing a drive to temperature extremes or to liquids.
- If a drive must be mailed, do the following: place the drive into a bubble pack mailer or other suitable form of protective packaging; label the package “Fragile: Handle With Care.”



## 4.4 Preventing Electrostatic Damage

Many electronic components are sensitive to electrostatic discharge (ESD). Circuitry design and structure determine the degree of sensitivity. Networks built into many integrated circuits provide some protection, but in many cases the discharge contains enough power to alter device parameters or melt silicon junctions.

A sudden discharge of static electricity from a finger or other conductor can destroy static-sensitive devices or microcircuitry. Often the spark is neither felt nor heard, but damage occurs. An electronic device exposed to electrostatic discharge may not be affected at all and can work perfectly throughout a normal cycle. It may function normally for a while, then degrade in the internal layers, reducing its life expectancy.

## 4.5 Packaging and Transporting Precautions

Use the following grounding precautions when packaging and transporting equipment:

- To avoid hand contact, transport products in static-safe containers such as tubes, bags, or boxes.
- Protect all electrostatic-sensitive parts and assemblies with conductive or approved containers or packaging.
- Keep electrostatic-sensitive parts in their containers until they arrive at static-free workstations.
- Place items on a grounded surface before removing them from their container.
- Always be properly grounded when touching a sensitive component or assembly.

- Place reusable electrostatic-sensitive parts from assemblies in protective packaging or non-conductive foam.
- Use transporters and conveyers made of antistatic belts and roller bushings. Ensure that mechanized equipment used for moving materials is wired to ground, and that proper materials were selected to avoid static charging. When grounding is not possible, use an ionizer to dissipate electric charges.

## 4.6 Workstation Precautions

Use the following grounding precautions at workstations:

- Cover the workstation with approved static-dissipative material (refer to Table 4-2).
- Use a wrist strap connected to a properly grounded work surface and use properly grounded tools and equipment.
- Use conductive field service tools, such as cutters, screwdrivers, and vacuums.
- When using fixtures that must directly contact dissipative surfaces, use fixtures made of static-safe materials only.
- Keep the work area free of nonconductive materials such as ordinary plastic assembly aids and Styrofoam.
- Handle electrostatic-sensitive components, parts, and assemblies by the case or PCM laminate. Handle them only at static-free workstations.
- Avoid contact with pins, leads, or circuitry.
- Turn off power and input signals before inserting or removing connectors or test equipment.

## 4.7 Grounding Equipment and Methods

Grounding equipment must include either a wrist strap or a foot strap at a grounded workstation.

- When seated, wear a wrist strap connected to a grounded system. Wrist straps are flexible straps with a minimum of one megohm  $\pm 10\%$  resistance in the ground cords. To provide proper ground, wear a strap snug against the skin at all times. On grounded mats with banana-plug connectors, connect a wrist strap with alligator clips.
- When standing, use foot straps and a grounded floor mat. Foot straps (heel, toe, or boot straps) can be used at standing workstations and are compatible with most types of shoes or boots. On conductive floors or dissipative floor mats, use them on both feet with a minimum of one-megohm resistance between the operator and ground. To be effective, the conductive strips must be worn in contact with the skin.
- Other grounding equipment recommended for use in preventing electrostatic damage includes:
  - Antistatic tape
  - Antistatic smocks, aprons, or sleeve protectors
  - Conductive bins and other assembly or soldering aids
  - Non-conductive foam
  - Conductive tabletop workstations with ground cord of one-megohm resistance
  - Static-dissipative table or floor mats with hard tie to ground
  - Field service kits
  - Static awareness labels
  - Material-handling packages

- Non-conductive plastic bags, tubes, or boxes
- Metal tote boxes
- Electrostatic voltage levels and protective materials

Table 4-1 shows how humidity affects the electrostatic voltage levels generated by different activities.

**Table 4-1**  
**Typical Electrostatic Voltage Levels**

Event	Relative Humidity		
	10%	40%	55%
Walking across carpet	35,000 V	15,000 V	7,500 V
Walking across vinyl floor	12,000 V	5,000 V	3,000 V
Motions of bench worker	6,000 V	800 V	400 V
Removing DIPS from plastic tube	2,000 V	700 V	400 V
Removing DIPS from vinyl tray	11,500 V	4,000 V	2,000 V
Removing DIPS from Styrofoam	14,500 V	5,000 V	3,500 V
Removing bubble pack from PCB	26,500 V	20,000 V	7,000 V
Packing PCBs in foam-lined box	21,000 V	11,000 V	5,000 V

 A product can be degraded by as little as 700 volts.

Table 4-2 lists the shielding protection provided by antistatic bags and floor mats.

**Table 4-2**  
**Static-Shielding Materials**

Material	Use	Voltage Protection Level
Antistatic plastic	Bags	1,500 V
Carbon-loaded plastic	Floor mats	7,500 V
Metallized laminate	Floor mats	5,000 V

---

## Removal and Replacement Procedures

This chapter provides removal and replacement procedures.

All screws removed during disassembly are P0 Phillips screws. There are four different sized screws that must be removed and replaced when servicing the computer. Make special note of the size and location of each screw during removal and replacement.

Refer to Appendix C, “Screw Listing,” for detailed information on screw sizes, locations, and usage.

## 5.1 Serial Number

Report the computer serial number to Compaq when requesting information or ordering spare parts. The serial number is located on the bottom of the computer (Figure 5-1).



**Figure 5-1: Serial Number Location**

## 5.2 Disassembly Sequence Chart

Use the chart below to determine the section number to be referenced when removing computer components.

**Table 5-1**  
**Disassembly Sequence Chart**

Section	Description	# of Screws Removed
5.3	Preparing the computer for disassembly	0
5.4	Computer feet	0
5.5	Mini PCI Communications Board	1
5.6	LED cover	0
5.7	Keyboard	2
5.8	Optical drive	1
5.9	Display	7
5.10	Heat sink	5
5.11	Processor	0
5.12	Top cover	15
5.13	Diskette drive	2
5.14	TouchPad	1
5.15	Hard drive Hard drive bracket	3
5.16	Disk cell Real Time Clock (RTC) battery	0
5.17	Fan Fan bracket	2
5.18	System board Optical drive alignment rail	7

## 5.3 Preparing the Computer for Disassembly

Perform the following steps before disassembling the computer. Consult the computer *Hardware Guide* for instructions on the following steps:

1. Turn off the computer.
2. Disconnect the AC Adapter and all external devices.
3. Remove any battery packs inserted into the computer.
4. Remove the memory expansion compartment cover.



## 5.4 Computer Feet

The computer feet are adhesive-backed rubber pads. The computer feet are included in the Plastics Kit (spare part number 233562-001). Refer to Figure 5-2 for the computer feet locations.

---

### Computer Feet Spare Part Number Information

---

**Plastics kit, includes:**

Left hinge cover  
Right hinge cover  
Mini PCI slot cover  
Memory expansion compartment cover

**Spare part number 233562-001**

Computer feet  
RJ-45 cover  
RJ-11 cover

---

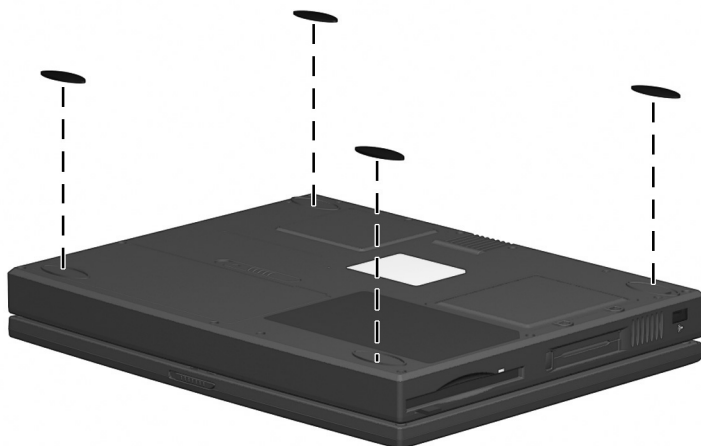

**Figure 5-2: Replacing the Computer Feet**

## 5.5 Mini PCI Communication Board

---

### Communication Boards Spare Part Number Information

---

#### Communication boards

Type III mini PCI combination 56 Kbps modem/network interface card (NIC)	233558-001
Type III mini PCI 56 Kbps modem board	233557-001
PC Card modem	233564-001

---

1. Prepare the computer for disassembly (Section 5.3).
2. Turn the computer bottom side up with the front facing you.
3. Remove the screws ❶ that secure the mini PCI compartment cover to the base enclosure (Figure 5-3).
4. Lift up the front edge of the cover and swing it toward the computer rear panel ❷.

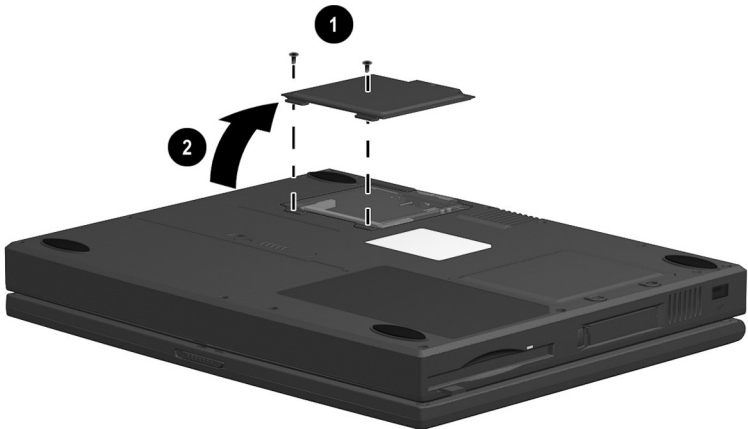

**Figure 5–3: Removing the Mini PCI Compartment Cover**

5. Remove the mini PCI compartment cover.
6. Pull away the plastic retention clips on each side of the mini PCI communication board ❶ (Figure 5-4). The board tilts upward.
7. Lift the edge of the board and slide it gently out of the connector ❷.

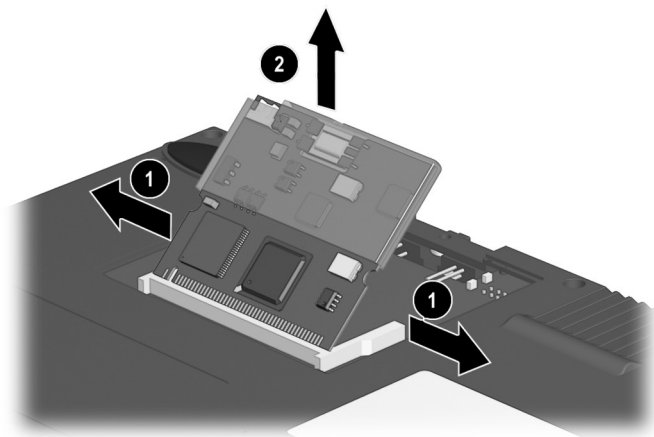

**Figure 5–4: Removing the Mini PCI Communication Board**

8. Place the board in an electrostatic-safe container.

Reverse the above procedure to install the mini PCI communication board.

## 5.6 LED Cover

---

### LED Cover Spare Part Number Information

---

LED cover

233559-001

---

1. Prepare the computer for disassembly (Section 5.3).
2. Turn the computer top side up with the front facing you.
3. Open the computer.
4. Lift up the left edge of the LED cover ❶ (Figure 5-5).
5. Lift up the front edge of the LED cover from left to right ❷.
6. Lift the LED cover straight up to remove it.

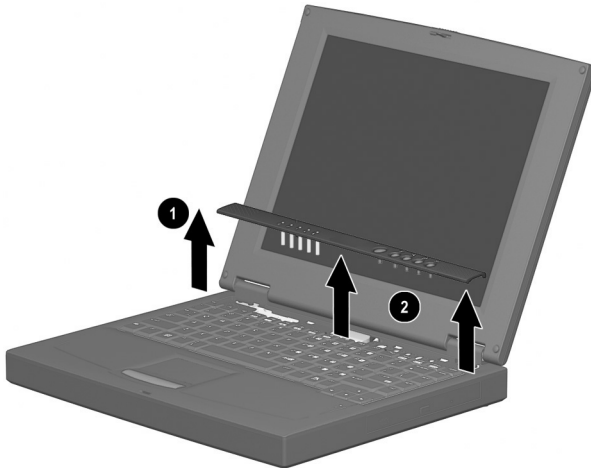

**Figure 5–5: Removing the LED Cover**

Reverse the above procedure to install the LED cover.

---

## 5.7 Keyboard

---

### Keyboard Spare Part Number Information

---

#### Keyboards

Arabic	233740-171	Korean	233740-AD1
Belgian	233740-381	Latin American Spanish	233740-161
Czech	233740-221	Norwegian	233740-091
Danish	233740-081	Portuguese	233740-131
French	233740-051	Russian	233740-251
French Canadian	233740-121	Swedish	233740-101
German	233740-041	Swiss	233740-BF1
Hebrew	233740-BB1	Spanish	233740-071
Hungarian	233740-211	Taiwanese	233740-AB1
International	233740-002	Turkish	233740-141
Italian	233740-061	U.K. English	233740-031
Japanese	233740-291	U.S. English	233740-001

---

1. Prepare the computer for disassembly (Section 5.3).
2. Remove the LED cover (Section 5.6).

3. Remove the two M2.5 × 5 screws securing the keyboard to the base enclosure ❶ (Figure 5-6).
4. Swing the back edge of the keyboard up and forward ❷ until it rests on the top cover.

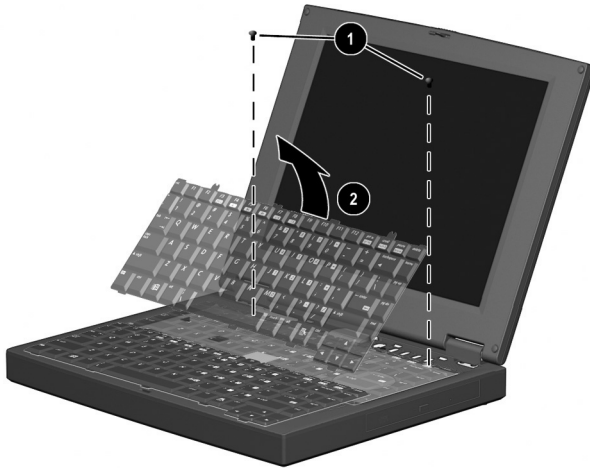

**Figure 5–6: Removing the Keyboard Screws**

5. Release the zero insertion force (ZIF) connector to which the keyboard cable is connected ❶ and disconnect the keyboard cable from the system board ❷ (Figure 5-7).

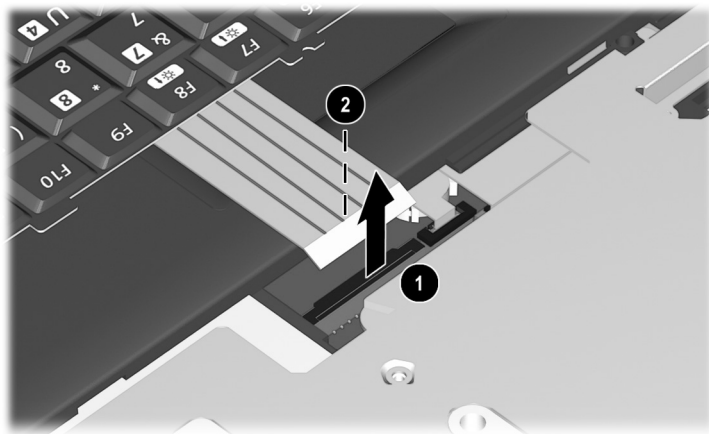

**Figure 5–7: Disconnecting the Keyboard Cable**

6. Remove the keyboard.

Reverse the above procedure to install the keyboard.

## 5.8 Optical Drive

---

### Optical Drives Spare Part Number Information

---

#### Optical drives

24X Max CD-ROM drive	233550-001
8X Max DVD-ROM drive	233548-001

---

<b>Optical drive alignment rail</b> (included in Hardware kit)	234005-001
--	------------

---

1. Prepare the computer for disassembly (Section 5.3) and, in the order below, remove the following components:
  - LED cover (Section 5.6)
  - Keyboard (Section 5.7)



2. Remove the M2.5 × 4.5 screw that secures the optical drive to the heat sink ❶ (Figure 5-8).
3. Push the back edge of the optical drive ❷ to the right to disconnect it from the connector on the system board.
4. Slide the optical drive out of the base enclosure ❸.

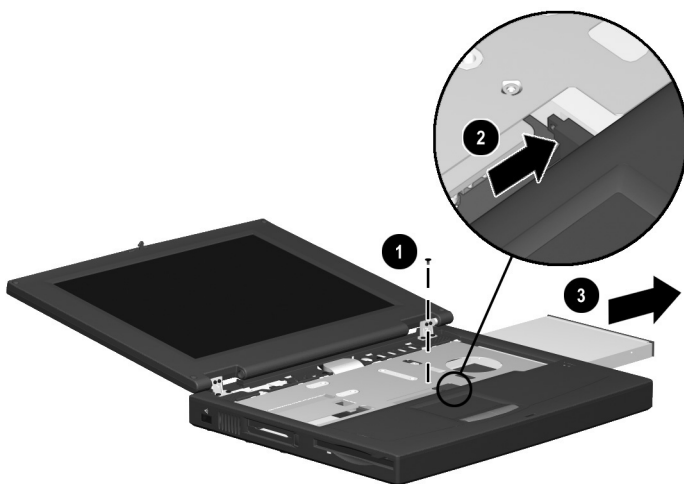

**Figure 5–8: Removing the Optical Drive**

Reverse the above procedure to install the optical drive.

## 5.9 Display

---

### Display Spare Part Number Information

---

#### Displays

14.1-inch, XGA, CTFT (used only with computer models with 1.0-GHz processors)	269909-001
14.1-inch, XGA, CTFT (used only with computer models with 850-, 800-, and 700-MHz processors)	233545-001
12.1-inch, SVGA, CTFT (used only with computer models with 850-, 800-, and 700-MHz processors)	233544-001

---



When the display screws are removed, the display assembly is unsupported. Make sure to provide support for the display assembly when removing the display screws.

---

1. Prepare the computer for disassembly (Section 5.3) and, in the order below, remove the following components:
  - LED cover (Section 5.6)
  - Keyboard (Section 5.7)
2. Close the computer.
3. Position the computer with the rear panel facing you.

4. Remove the two M2.5 × 4.5 screws securing the hinge covers to the display hinges ❶ (Figure 5-9).
5. Lift the hinge covers straight up to remove them ❷.

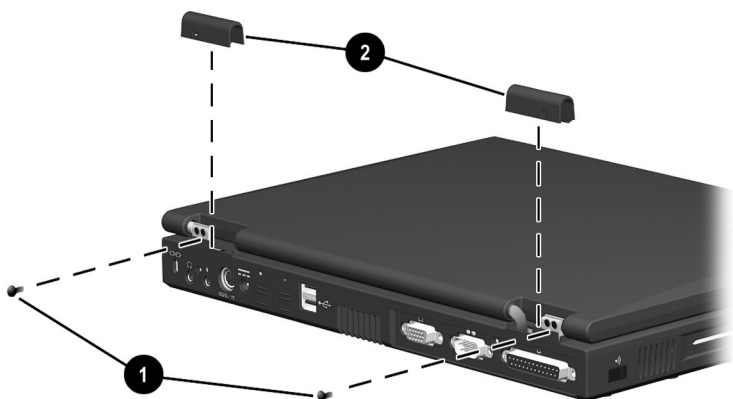

**Figure 5–9: Removing the Hinge Covers**



The right and left hinge covers are included in the Plastics Kit and are not interchangeable.

---

---

### Hinge Covers Spare Part Number Information

---

**Plastics kit, includes:**

Left hinge cover  
Right hinge cover  
Mini PCI slot cover  
Memory expansion compartment cover

**Spare part number 233562-001**

Computer feet  
RJ-45 cover  
RJ-11 cover

---

6. Position the computer with the front facing you.
7. Open the computer.
8. Remove the M2.5 × 4.5 screw securing the display ground cable to the base enclosure ❶ (Figure 5-10).
9. Disconnect the display video cable ❷.
10. Remove the four M2.5 × 7 screws securing the display hinges to the base enclosure ❸.

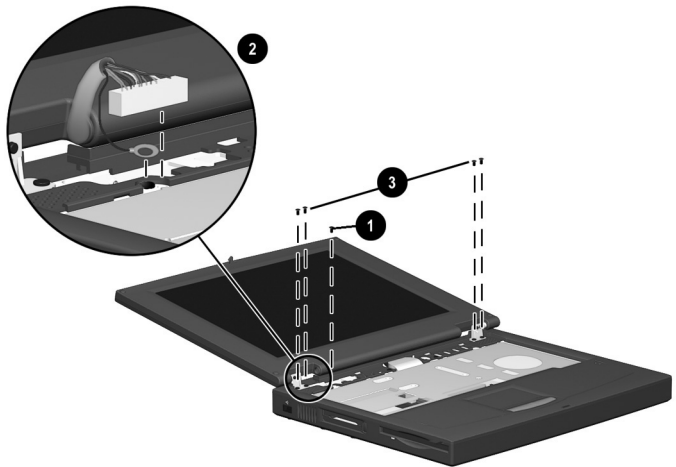

**Figure 5–10: Removing the Display**

11. Remove the display.

Reverse the above procedure to install the display.



To ensure proper alignment of the display when replacing it, loosely install the screws in the ①, ②, ③, ④, ⑤ sequence indicated in Figure 5-11. After all screws have been loosely installed, tighten them.

---

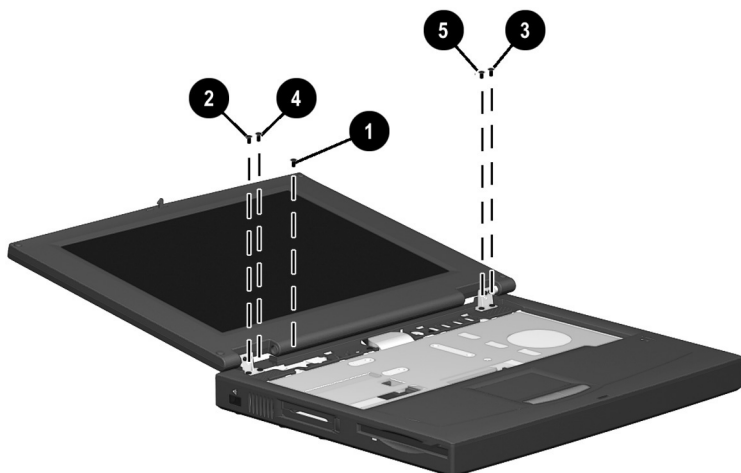

**Figure 5–11: Installing the Display Screws**

Reverse the above procedure to install the display.

## 5.10 Heat Sink

---

### Heat Sink Spare Part Number Information

---

<b>Heat sink</b> (used only with computer models with 1.0-GHz processors)	269863-001
<b>Heat sink</b> (used only with computer models with 850-, 800-, and 700-MHz processors)	233555-001

---

1. Prepare the computer for disassembly (Section 5.3) and, in the order below, remove the following components:
  - LED cover (Section 5.6)
  - Keyboard (Section 5.7)
  - Optical drive (Section 5.8)
  - Display (Section 5.9)



The heat sink is secured to the base enclosure by five screws that are two different sizes. Be sure to carefully note the size and location of each screw.

---

2. Remove the four M2.5 × 7 screws ❶ and the M2.5 × 4.5 screw ❷ securing the heat sink to the base enclosure (Figure 5-12).

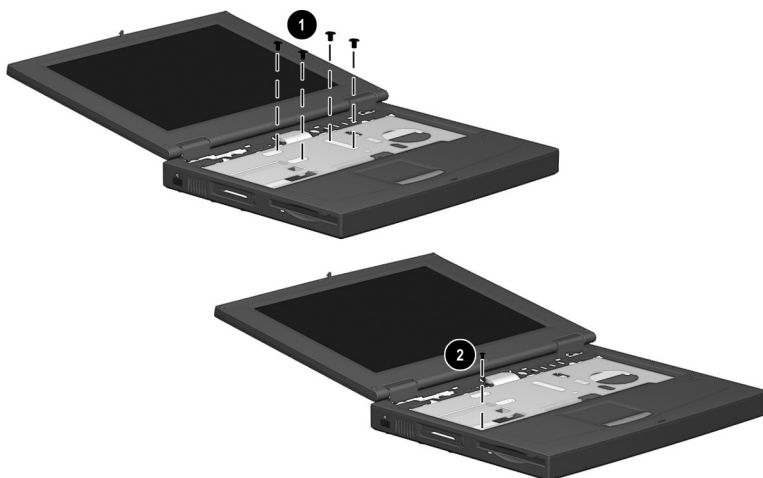

**Figure 5–12: Removing the Heat Sink Screws**

3. Lift the front edge of the heat sink and swing it up and back until the shield rests at a 45-degree angle ❶ (Figure 5-13).
4. Pull the heat sink away from the base enclosure at a 45-degree angle ❷ and remove it from the base enclosure.

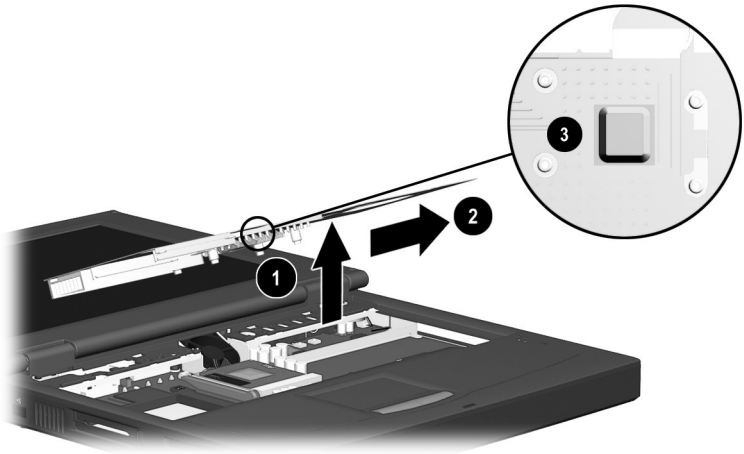

**Figure 5–13: Removing the Heat Sink**

A thermal pad ❸ is installed on the heat sink and makes contact with the processor. Any time the heat sink is removed, inspect the thermal pad for damage.



Follow these steps to replace a damaged thermal pad:

- a. Carefully peel the old thermal pad from the heat sink area.
- b. Use a plastic straight edge tool (such as a credit card) to remove any thermal pad residue. Glue residue does not need to be totally removed. The glue used on the thermal pad has thermal conducting properties and will flow together with the glue from the new thermal pad.



**CAUTION:** Do not use any metal tools when removing thermal pad residue from the heat sink or processor. Failure to follow this caution can result in damage to these components and system failure.

---

- c. Peel the backing from the new thermal pad and position it on the heat sink in the same location as the old pad.

## 5.11 Processor

---

### Processor Spare Part Number Information

---

#### Processors

1.0 GHz Intel Pentium III	269861-001
1.0 GHz Celeron	269862-001
850 MHz Intel Pentium III	253593-001
850 MHz Intel Celeron	253594-001
800 MHz Intel Pentium III	233551-001
700 MHz Intel Celeron	233549-001

---

1. Prepare the computer for disassembly (Section 5.3) and, in the order below, remove the following components:
  - LED cover (Section 5.6)
  - Keyboard (Section 5.7)
  - Optical drive (Section 5.8)
  - Heat sink (Section 5.10)

2. Slide the processor lever to the left **1** and then swing it up and forward **2** until it is vertical (Figure 5-14).
3. Lift the outside edges of the processor straight up to remove it from the system board **3**.



When replacing the processor, make sure the processor is seated in the processor socket with the gold triangle in the rear left corner **4**.

---



If there is any thermal pad residue on the processor **5**, use a plastic straight edge tool (such as a credit card) to remove it. Refer to Section 5.10, “Heat Sink,” for instructions on replacing the thermal pad on the heat sink.

---

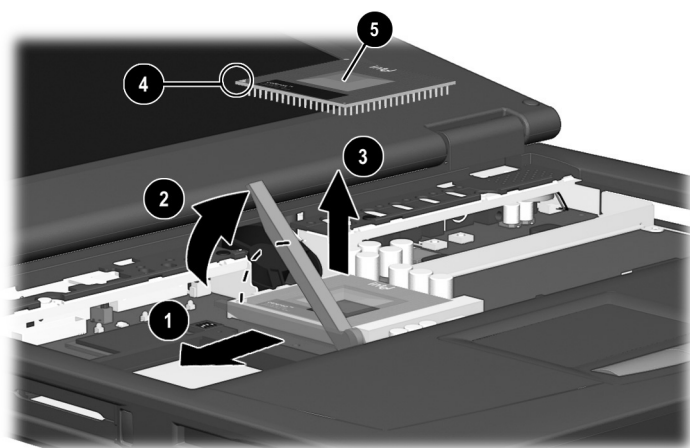

**Figure 5–14: Removing the Processor**



**CAUTION:** Do not use any metal tools when removing thermal pad residue from the heat sink or processor. Failure to follow this caution can result in damage to these components and system failure.

---

## 5.12 Top Cover

---

### Top Cover Spare Part Number Information

---

**Top cover**

233568-001

---

1. Prepare the computer for disassembly (Section 5.3) and, in the order below, remove the following components:
    - LED cover (Section 5.6)
    - Keyboard (Section 5.7)
    - Optical drive (Section 5.8)
    - Display (Section 5.9)
    - Heat sink (Section 5.10)
  2. Turn the computer bottom side up with the front facing you.
- 



The top cover is secured to the base enclosure by 15 screws that are two different sizes. Be sure to carefully note the size and location from which each screw was removed.

---

3. Remove the 10 M2.5 × 7 screws ❶ and the three M2.5 × 4.5 screws ❷ securing the top cover to the base enclosure (Figure 5-15).

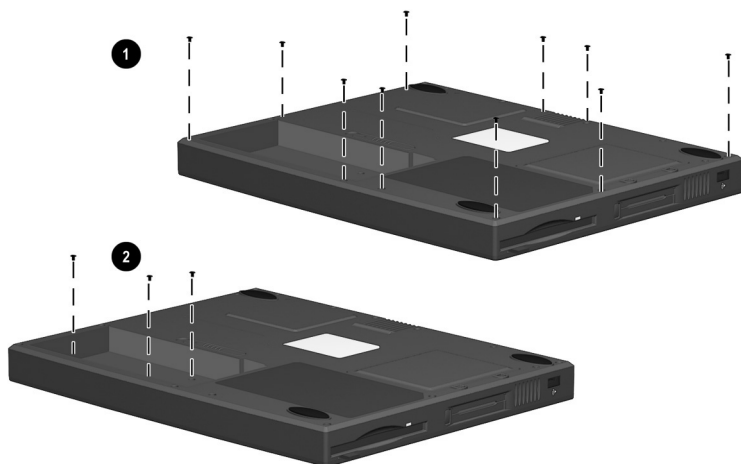

**Figure 5–15: Removing the Top Cover Screws**

4. Turn the computer top side up with the front facing you.
5. Disconnect the diskette drive cable from the low insertion force (LIF) connector on the system board ❶ (Figure 5-16).
6. Disconnect the TouchPad cable from the LIF connector on the system board ❷.
7. Remove the two M2.5 × 4.5 screws securing the top cover to the base enclosure ❸.
8. Lift the top cover straight up to remove it from the base enclosure ❹.

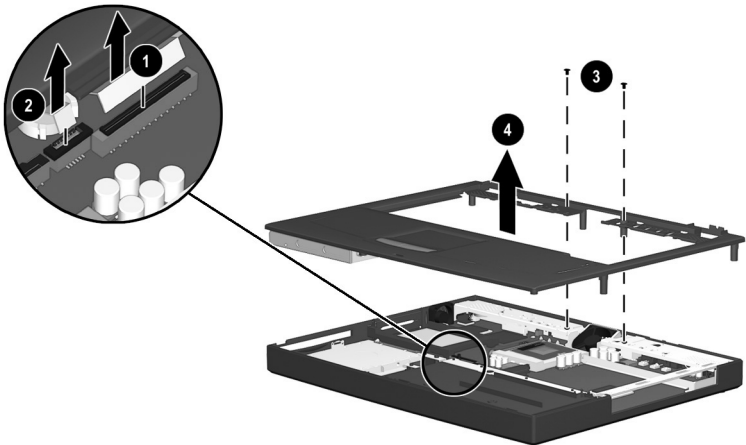

**Figure 5–16: Removing the Top Cover**

Reverse the above procedure to install the top cover.

## 5.13 Diskette Drive

---

### Diskette Drive Spare Part Number Information

---

Diskette drive

233553-001

---

1. Prepare the computer for disassembly (Section 5.3) and, in the order below, remove the following components:
  - LED cover (Section 5.6)
  - Keyboard (Section 5.7)
  - Optical drive (Section 5.8)
  - Display (Section 5.9)
  - Heat sink (Section 5.10)
  - Top cover (Section 5.12)
2. Turn the top cover bottom side up with the front facing you.

3. Remove the two M2.5 × 4.5 screws securing the diskette drive to the top cover ❶ (Figure 5-17).
4. Remove the tape adhering the diskette drive and TouchPad cables to the top cover ❷.
5. Remove the diskette drive from the top cover ❸.

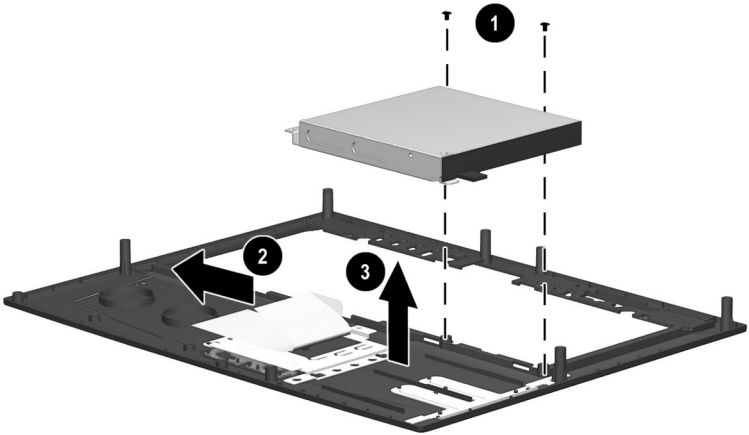

**Figure 5–17: Removing the Diskette Drive**

Reverse the above procedure to install the diskette drive.



When installing the diskette drive in the top cover, make sure the tab in the front right corner of the diskette drive fits into the slot in the front right corner of the top cover.

---



## 5.14 TouchPad

---

### TouchPad Spare Part Number Information

---

**TouchPad**

236076-001

---

1. Prepare the computer for disassembly (Section 5.3) and, in the order below, remove the following components:
  - LED cover (Section 5.6)
  - Keyboard (Section 5.7)
  - Optical drive (Section 5.8)
  - Display (Section 5.9)
  - Heat sink (Section 5.10)
  - Top cover (Section 5.12)

2. Remove the M2.5 × 4.5 screw ❶ securing the TouchPad bracket to the top cover (Figure 5-18).
3. Slide the TouchPad bracket forward ❷.
4. Lift the TouchPad bracket up and remove it from the top cover ❸.

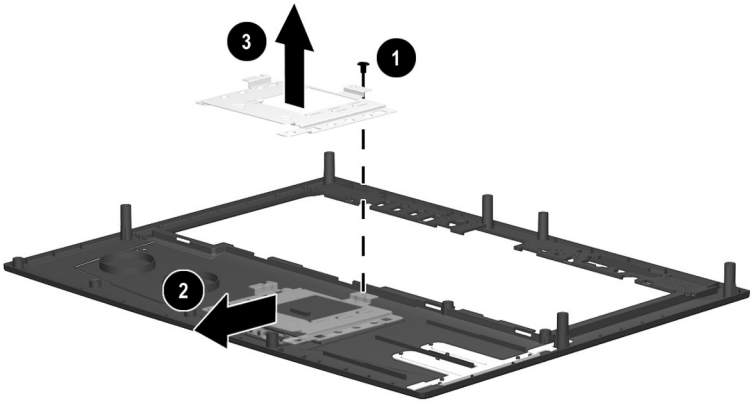

**Figure 5–18: Removing the TouchPad Bracket**

5. Remove the TouchPad board and cable from the top cover (Figure 5-19).

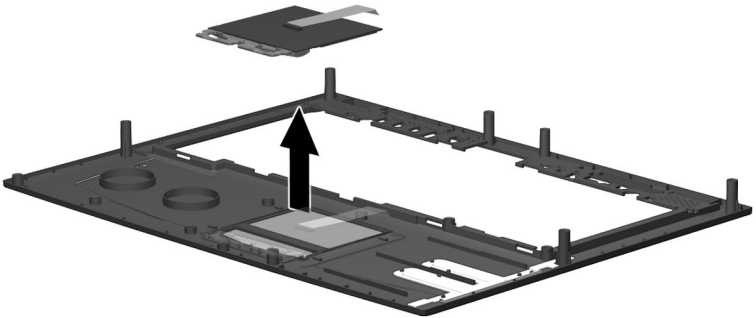

**Figure 5–19: Removing the TouchPad**

Reverse the above procedure to install the TouchPad.

## 5.15 Hard Drive

---

### Hard Drive Spare Part Number Information

---

#### Hard drives

20 GB hard drive	253596-001
15 GB hard drive	253595-001
10 GB hard drive	233554-001

---

<b>Hard drive bracket</b> (included in Hardware kit)	234005-001
--	------------

---



**CAUTION:** To prevent damage to the computer and hard drive and loss of information, shut down the computer before removing the hard drive from the computer. Do not remove the hard drive while the computer is on, in Suspend (Standby), or in Hibernation. If you are not sure whether the computer is in Hibernation, turn the computer on, then shut it down. If the computer is running a retail version of a Windows operating system, shut down the computer before removing any drive.

---

1. Prepare the computer for disassembly (Section 5.3) and, in the order below, remove the following components:
  - LED cover (Section 5.6)
  - Keyboard (Section 5.7)
  - Optical drive (Section 5.8)
  - Display (Section 5.9)
  - Heat sink (Section 5.10)
  - Top cover (Section 5.12)

2. Remove the three M2.5 × 5.5 screws ❶ securing the hard drive and hard drive bracket to the base enclosure (Figure 5-20).
3. Remove the hard drive bracket ❷ from the base enclosure.
4. Slide the hard drive toward the front of the base enclosure ❸ to disconnect it from the system board.
5. Remove the hard drive from the base enclosure ❹.

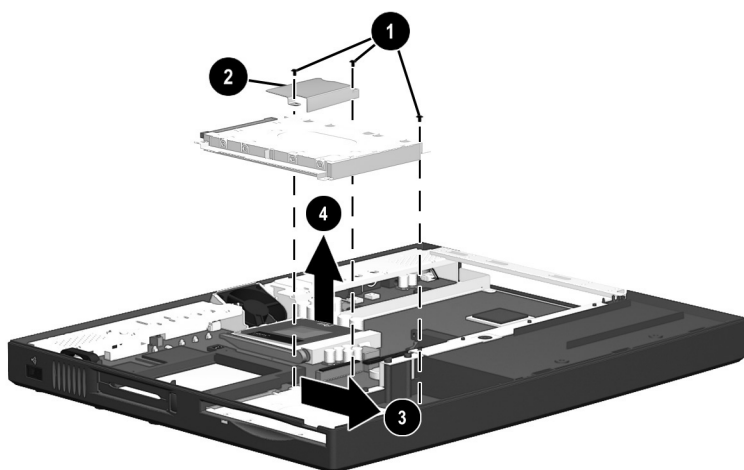

**Figure 5–20: Removing the Hard Drive**

Reverse the above procedure to install the hard drive.

## 5.16 Disk Cell Real Time Clock (RTC) Battery

---

### Disk Cell RTC Battery Spare Part Number Information

---

Disk cell RTC battery

236359-001

---

1. Prepare the computer for disassembly (Section 5.3) and, in the order below, remove the following components:
  - LED cover (Section 5.6)
  - Keyboard (Section 5.7)
  - Optical drive (Section 5.8)
  - Display (Section 5.9)
  - Heat sink (Section 5.10)
  - Top cover (Section 5.12)

2. Lift the edge of the battery to disconnect it from its socket (Figure 5-21).

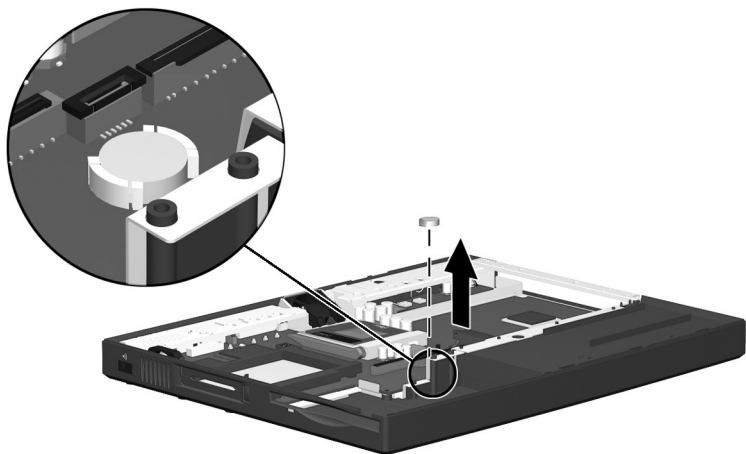

**Figure 5–21: Removing the Disk Cell Battery**

Reverse the above procedure to install the disk cell RTC battery.

## 5.17 Fan

---

### Fan Spare Part Number Information

---

<b>Fan</b>	233552-001
<b>Fan bracket</b> (included in Hardware kit)	234005-001

---

1. Prepare the computer for disassembly (Section 5.3) and, in the order below, remove the following components:
  - LED cover (Section 5.6)
  - Keyboard (Section 5.7)
  - Optical drive (Section 5.8)
  - Display (Section 5.9)
  - Heat sink (Section 5.10)
  - Top cover (Section 5.12)



2. Remove the two M2.5 × 4.5 screws ❶ securing the fan bracket and fan to the system board (Figure 5-22).
3. Disconnect the fan cable from the system board ❷.
4. Remove the fan bracket ❸ and fan ❹ from the base enclosure.

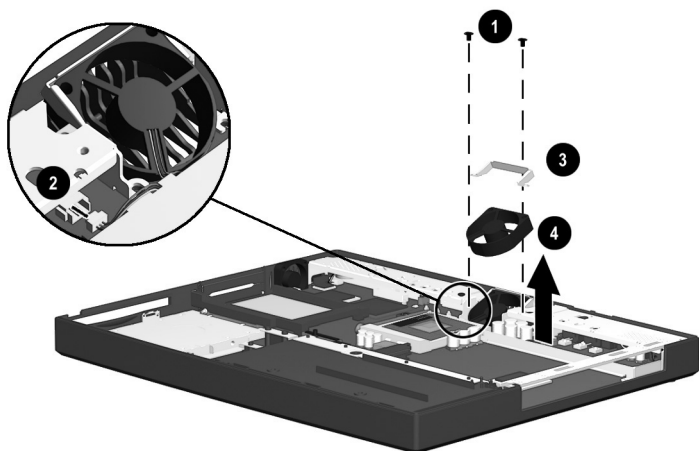

**Figure 5–22: Removing the Fan**

Reverse the above procedure to install the fan.



When installing the fan, route the fan cable **1** under the clip **2** on the processor mount as indicated in Figure 5-23.

---

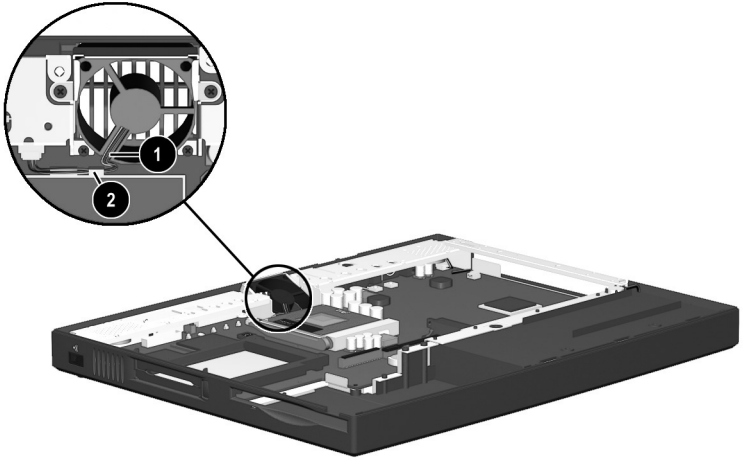

**Figure 5–23: Routing the Fan Cable**

---

## 5.18 System Board

---

### System Board Spare Part Number Information

---

<b>System board</b> (includes 64 MB SDRAM, left and right speakers, and left and right brackets)	233567-001
--	------------

---

<b>Optical drive alignment rail</b> (included in Hardware kit)	234005-001
--	------------

---

1. Prepare the computer for disassembly (Section 5.3) and, in the order below, remove the following components:
  - Mini PCI communications board (Section 5.3)
  - LED cover (Section 5.6)
  - Keyboard (Section 5.7)
  - Optical drive (Section 5.8)
  - Display (Section 5.9)
  - Heat sink (Section 5.10)
  - Processor (Section 5.11)
  - Top cover (Section 5.12)
  - Hard drive (Section 5.15)
  - Fan (Section 5.17)
2. Turn the base enclosure bottom side up with the rear panel facing you.

3. Remove the four M2.5 × 7 screws from the bottom of the base enclosure securing the system board to the base enclosure (Figure 5-24).

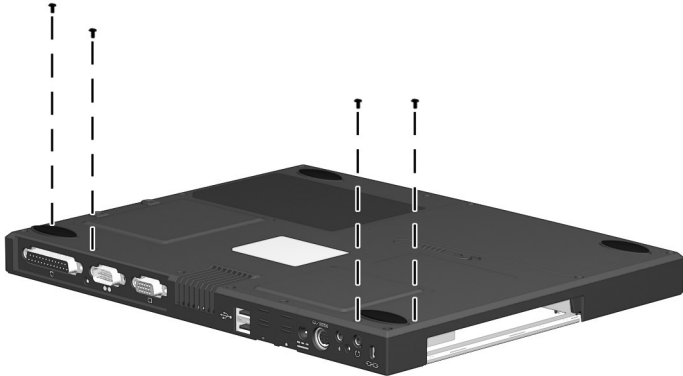

**Figure 5–24: Removing the Exterior System Board Screws**

4. Turn the base enclosure top side up with the front facing you.

5. Remove the M2.5 × 5.5 screw ❶ securing the optical drive alignment rail to the base enclosure (Figure 5-25).
6. Remove the two M2.5 × 5.5 screws ❷ securing the system board to the base enclosure.
7. Remove the optical drive alignment rail ❸.
8. Disconnect the microphone cable ❹ from the system board.

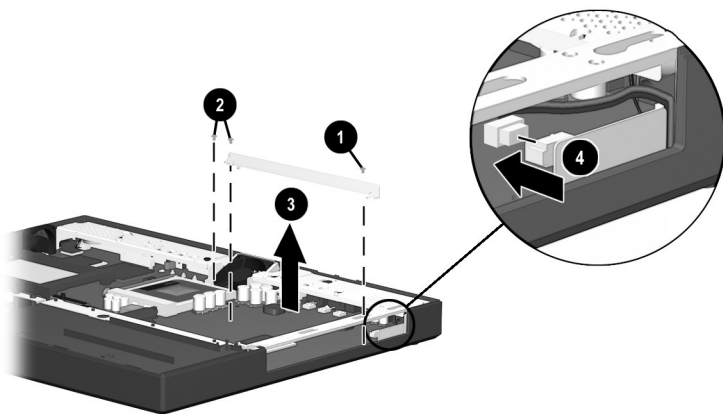

**Figure 5–25: Removing the Interior System Board Screws, Optical Drive Alignment Rail, and Disconnecting the Microphone Cable**

9. Make sure the PC Card eject button **1** is fully depressed (Figure 5-26).
10. Lift up the front edge of the system board until the board is at a 45-degree angle **2**.
11. Pull the system board away from the base enclosure at a 45-degree angle **3**.

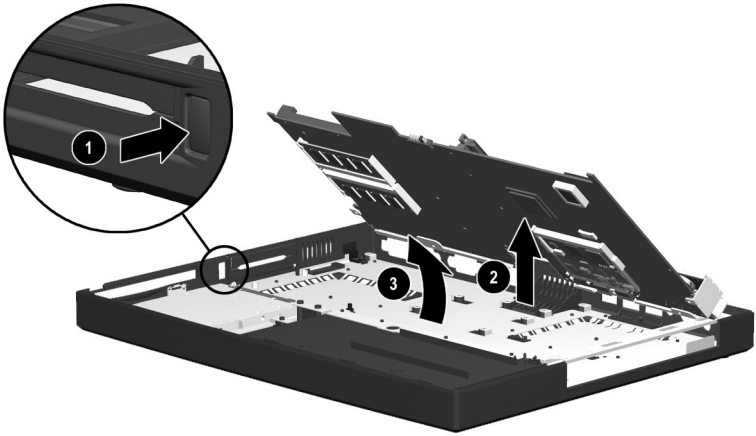
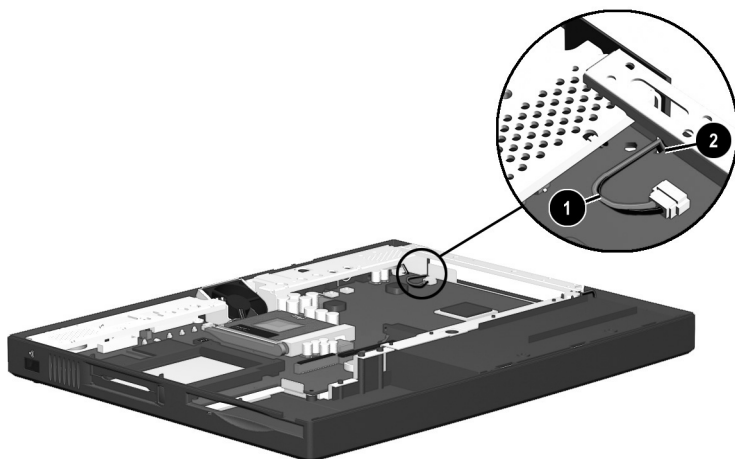

**Figure 5–26: Removing the System Board**

Reverse the above procedure to install the system board.



When installing the system board, route the microphone cable **1** through the slot **2** on the right side of the system board as indicated in Figure 5-27.



**Figure 5–27: Routing the Microphone Cable**

---

# Specifications

This chapter provides physical and performance specifications.

---

**Table 6-1**  
**Computer**

---

### Dimensions

Height	12.5 in	318 mm
Depth	1.7 in	42 mm
Width	9.8 in	248 mm

---

### Weight

7.1 to 7.4 lb depending on display configuration	3.2 to 3.4 kg depending on display configuration
--	--

---

### Standalone (Battery) Power Requirements

Nominal operating voltage (Li ion)	11.1 VDC
Nominal operating voltage (NiMH)	10.8 VDC

---

### AC Adapter Power Requirements

Rated input power	90 to 264 VAC RMS (auto switching
Rated input current	< 60 W
Rated frequency	47 to 63 Hz

---

### Temperature

Operating	50 to 95° F	10 to 35° C
Nonoperating	-4 to 140° F	-20 to 60° C

---



---

**Table 6-1**  
**Computer (Continued)**

---

**Relative Humidity** (non-condensing)

Operating	20 to 80%
Nonoperating	20 to 90%, 101.6° F/38.7° C maximum wet bulb

---

**Altitude** (unpressurized)

Operating	0 to 10,000 ft	0 to 3,048 m
Nonoperating	0 to 40,000 ft	0 to 9,144 m

---

**Shock**

Operating	0 G, 11 ms, half sine
Nonoperating	60 G, 11 ms, half sine

---

**Vibration**

Operating	0.5 G zero to peak, 10 to 500 Hz, 0.5 oct/min sweep rate
Nonoperating	1.0 G zero to peak, 10 to 500 Hz, 0.50 oct/min sweep rate

---



---

Applicable product safety standards specify thermal limits for plastic surfaces. The computer operates well within this range of temperatures.

---

**Table 6-2**  
**14.1-inch XGA, TFT Display**

<b>Dimensions</b>		
Height	8.42 in	21.40 cm
Depth	11.22 in	28.50 cm
Width	14.10 in	35.81 cm
<b>Number of colors</b>	Up to 16.8 million	
<b>Contrast ratio</b>	180:1	
<b>Brightness</b>	>150 nits typical	
<b>Pixel resolution</b>		
Pitch		0.279 × 0.279 mm
Format	1024 × 768	
Configuration	RGB vertical stripe	
<b>Backlight</b>	Cold cathode fluorescent, 1 tube	
<b>Character display</b>	80 × 25	
<b>Refresh</b>	60 Hz	
<b>Total Power Consumption</b>	8.0 W	

---

**Table 6-3**  
**12.1-inch SVGA, TFT Display**

---

**Dimensions**

Height	7.83 in	19.90 cm
Depth	10.83 in	27.50 cm
Width	12.10 in	30.74 cm

---

**Number of colors** Up to 16.8 million

---

**Contrast ratio** 250:1

---

**Brightness** >120 nits typical

---

**Pixel resolution**

Pitch		0.3075 × 0.3075 mm
Format	800 × 600	
Configuration	RGB vertical stripe	

---

**Backlight** Cold cathode fluorescent, 1 tube

---

**Character display** 80 × 25

---

**Refresh** 60 Hz

---

**Total Power Consumption** 4.5 W

---

**Table 6-4**  
**10.0-GB Hard Drive**

	<b>20.0 GB</b>	<b>15.0 GB</b>	<b>10.0 GB</b>
<b>User capacity per drive<sup>1</sup></b>	20.0 GB	15.0 GB	10.0 GB
<b>Drive height</b> (in mm, with drive frame)	9.5 mm	9.5 mm	9.5 mm
<b>Drive width</b> (in mm, with drive frame)	70.0 mm	70.0 mm	63.5 mm
<b>Interface type</b>	ATA-5	ATA-4	ATA-4
<b>Seek times</b> (typical read, including setting)			
Single track	2.5 ms	2.5 ms	2.5 ms
Average	12.0 ms	12.0 ms	13.0 ms
Full stroke	23.0 ms	23.0 ms	24.0 ms
<b>User addressable sectors<sup>3</sup></b>	39,070,080	23,579,136	19,640,880
<b>Logical configuration</b>			
Cylinders	22,784	16,683	16,683
Heads	16	16	16
Sectors per track	63	63	63

<sup>1</sup>1 GB = 1,000,000,000 bytes.

<sup>2</sup>System capability may differ.

<sup>3</sup>Actual drive specifications may differ slightly.

Certain restrictions and exclusion apply. Consult the Compaq Customer Support Center for details.

**Table 6-4**  
**10.0-GB Hard Drive (Continued)**

	20.0 GB	15.0 GB	10.0 GB
<b>Physical configuration</b>			
Cylinders <sup>3</sup>	22,784	25,800	22,784
Heads	4	2	2
Sectors per track <sup>3</sup>	293–560	398–731	293–560
Bytes per sector	512	512	512
<b>Buffer size<sup>3</sup></b>	2 MB	2 MB	512 KB
<b>Disk rotational speed</b>	4200 rpm	4200 rpm	4200 rpm
<b>Transfer rate</b>			
Interface max (Mbytes/sec) <sup>2</sup>	66.6	66.6	66.6
Media (Mbits/sec) <sup>3</sup>	109–203	109–203	109–203

<sup>1</sup>1 GB = 1,000,000,000 bytes.

<sup>2</sup>System capability may differ.

<sup>3</sup>Actual drive specifications may differ slightly.

Certain restrictions and exclusion apply. Consult the Compaq Customer Support Center for details.

**Table 6-5  
Diskette Drive**

<b>Diskette size</b>	3.5 inch	
<b>Light</b>	On system	
<b>Height</b>	0.5 in	12.7 mm
<b>Bytes per sector</b>	512	
<b>Sectors per track</b>		
High density	18 (1.44-MB)	15 (1.2-MB)
Low density	9	
<b>Tracks per side</b>		
High density	80	
Low density	80	
<b>Read/write heads</b>	2	
<b>Average seek times</b>		
Track-to-track (high/low)	3 ms	6 ms
Average (high/low)	95 ms	174 ms
Settling time	15 ms	
Latency average	100 ms	

**Table 6-6**  
**CD-ROM Drive**

<b>Applicable disk</b>	CD-ROM (Mode 1, 2, and 3) CD-XA ready (Mode 2, Form 1 and 2) CD-I ready (Mode 2, Form 1 and 2) CD-R (read only) CD Plus Photo CD (single/multisession) CD-Extra Video CD CD-WO (fixed packets only) CD-Bridge	
<b>Center hole diameter</b>	.59 in	15 mm
<b>Disk diameter</b>	12 cm, 8 cm	
<b>Disk thickness</b>	1.2 mm	
<b>Track pitch</b>	1.6 $\mu$	
<b>Access time</b>		
Random	< 150 ms	
Full Stroke	< 300 ms	
<b>Cache buffer</b>	128 KB	
<b>Data transfer rate</b>		
Sustained, 24X	2400 KB/sec (150 KB/sec at 1X)	
Variable	1500 to 3600 KB/sec (10X to 24X)	
Normal PIO Mode 4 (single burst)	16.66 KB/sec	
<b>Startup time</b>	< 8 seconds	
<b>Stop time</b>	< 4 seconds	

**Table 6-7**  
**DVD-ROM Drive**

<b>Applicable disk</b>	DVD-5, DVD-9, DVD-10 CD-ROM (Mode 1 and 2) CD Digital Audio CD-XA ready (Mode 2, Form 1 and 2) CD-I ready (Mode 2, Form 1 and 2) CD-R (read only) CD Plus Photo CD (single/multisession) CD-Bridge	
<b>Center hole diameter</b>	.59 in	15 mm
<b>Disk diameter</b>	12 cm, 8 cm	
<b>Disk thickness</b>	1.2 mm	
<b>Track pitch</b>	.74 $\mu$	
<b>Access time</b>		
Random	< 150 ms	
Full Stroke	< 225 ms	
<b>Audio output level</b>		
Lineout	0.7 V rms	
Headphone	none	
<b>Cache buffer</b>	128 KB	
<b>Data transfer rate</b>		
Sustained, 1X DVD rate	150 KB/sec	
Sustained, 16X DVD rate	2400 KB/sec	
Sustained, 1X DVD rate	1380 KB/sec	
Sustained, 4X DVD rate	5520 KB/sec	
Normal IO Mode 4 (single burst)	16.6 MB/sec	
<b>Startup time</b>	< 15 seconds	
<b>Stop time</b>	< 6 seconds	



---

**Table 6-8**  
**AC Adapter**

---

<b>Weight</b>	0.45 lb	0.21 kg
<b>Power supply (input)</b>		
Operating voltage	100 to 240 VAC RMS Nominal	
Operating current	1.5 A RMS	
Operating frequency range	50 to 60 Hz Nominal	
Maximum transient	4/50 kV	

---

**Table 6-9**  
**Battery Packs**

---

**Dimensions**

Lithium ion (Li ion)		
Height	0.83 in	21 mm
Length	3.15 in	166
Width	6.55 in	81
Weight	0.97 lb	0.44 kg
Cells	9 Li ion	
Nickel Metal Hydride (NiMH)		
Height	0.83 in	21 mm
Length	3.15 in	166
Width	6.55 in	81
Weight	0.132 lb	0.60 kg
Cells	9 NiMH	

---

**Energy**

Li ion		
Voltage	11.1 V	
Amp-hour capacity	4.8 Ah	
Watt-hour capacity	53.2 Wh	
NiMH		
Voltage	10.8 V	
Amp-hour capacity	10.8 Ah	
Watt-hour capacity	48.6 Wh	

---

**Environmental requirements**

Temperature		
Operating	50° F to 104° F	10° C to 40° C
Nonoperating	-12° F to 140° F	-30° C to 60° C

---

---

**Table 6-10**  
**System DMA**

---

<b>Hardware DMA</b>	<b>System Function</b>
DMA0	Available for audio
DMA1	Entertainment audio (default; alternate = DMA0, DMA3, none)
DMA2	Diskette drive
DMA3	ECP parallel port LPT1 (default; alternate = DMA0, none)
DMA4	DMA controller cascading (not available)
DMA5	Available for PC Card
DMA6	not assigned
DMA7	not assigned

---

 PC Card controller can use DMA 1, 2, or 5.

---

**Table 6-11**  
**System Interrupts**

<b>Hardware IRQ</b>	<b>System Function</b>
IRQ0	System timer
IRQ1	Keyboard controller
IRQ2	Cascaded
IRQ3	COM2
IRQ4	COM1
IRQ5	Audio (default)*
IRQ6	Diskette drive
IRQ7	Parallel port
IRQ8	Real time clock (RTC)
IRQ9	Infrared
IRQ10	System use
IRQ11	System use
IRQ12	Internal point stick or external mouse
IRQ13	Coprocessor (not available to any peripheral)
IRQ14	IDE interface (hard drive and optical drive)
IRQ15	System use

 PC Cards may assert IRQ3, IRQ4, IRQ5, IRQ7, IRQ9, IRQ10, IRQ11, or IRQ15. Either the infrared or the serial port may assert IRQ3 or IRQ 4.

\*Default configuration; audio possible configurations are IRQ5, IRQ7, IRQ9, IRQ10, or none.

---

**Table 6-12**  
**System I/O Addresses**

---

<b>I/O Address (hex)</b>	<b>System Function (shipping configuration)</b>
000 - 00F	DMA controller no. 1
010 - 01F	unused
020 - 021	Interrupt controller no. 1
022 - 024	Opti chipset configuration registers
025 - 03F	unused
02E - 02F	87334 "Super IO" configuration for CPU
040 - 05F	Counter/timer registers
044 - 05F	unused
060	Keyboard controller
061	Port b
062 - 063	unused
064	Keyboard controller
065 - 06F	unused
070 - 071	NMI enable/real time clock
072 - 07F	unused
080 - 08F	DMA page registers
090 - 091	unused
092	Port A
093 - 09F	unused
0A0 - 0A1	Interrupt controller no. 2

---

**Table 6-12**  
**System I/O Addresses (*Continued*)**

<b>I/O Address (hex)</b>	<b>System Function (shipping configuration)</b>
0A2 - 0BF	unused
0C0 - 0DF	DMA controller no. 2
0E0 - 0EF	unused
0F0 - 0F1	Coprocessor busy clear/reset
0F2 - 0FF	unused
100 - 16F	unused
170 - 177	Secondary fixed disk controller
178 - 1EF	unused
1F0 - 1F7	Primary fixed disk controller
1F8 - 200	unused
201	Joystick (decoded in ESS1688)
202 - 21F	unused
220 - 22F	Entertainment audio
230 - 26D	unused
26E - 26	unused
278 - 27F	unused
280 - 2AB	unused
2A0 - 2A7	unused
2A8 - 2E7	unused
2E8 - 2EF	Reserved serial port

---

**Table 6-12**  
**System I/O Addresses (*Continued*)**

---

<b>I/O Address (hex)</b>	<b>System Function (shipping configuration)</b>
2F0 - 2F7	unused
2F8 - 2FF	Infrared port
300 - 31F	unused
320 - 36F	unused
370 - 377	Secondary diskette drive controller
378 - 37F	Parallel port (LPT1/default)
380 - 387	unused
388 - 38B	FM synthesizer - OPL3
38C - 3AF	unused
3B0 - 3BB	VGA
3BC - 3BF	Reserved (parallel port/no EPP support)
3C0 - 3DF	VGA
3E0 - 3E1	PC Card controller in CPU
3E2 - 3E3	unused
3E8 - 3EF	Internal modem
3F0 - 3F7	"A" diskette controller
3F8 - 3FF	Serial port (COM1/default)
CF8 - CFB	PCI configuration index register (PCIDIVO-1)
CFC - CFF	PCI configuration data register (PCIDIVO-1)

---

---

**Table 6-13**  
**System Memory Map**

---

<b>Size</b>	<b>Memory Address</b>	<b>System Function</b>
640 K	00000000 - 0009FFFF	Base memory
128 K	000A0000 - 000BFFFF	Video memory
48 K	000C0000 - 000CBFFF	Video BIOS
160 K	000C8000 - 000E7FFF	unused
64 K	000E8000 - 000FFFFF	System BIOS
15 M	00100000 - 00FFFFFF	Extended memory
58 M	01000000 - 047FFFFFFF	Super extended memory
58 M	04800000 - 07FFFFFFF	unused
2 M	08000000 - 080FFFFFFF	Video memory (direct access)
4 G	08200000 - FFFEFFFF	unused
64 K	FFFF0000 - FFFFFFFF	System BIOS

---



# A

---

## Connector Pin Assignments

---

---

**Table A-1**  
**Stereo Speaker/Headphone**

---



---

<b>Pin</b>	<b>Signal</b>	<b>Pin</b>	<b>Signal</b>
1	Audio out	2	Ground

---

---

**Table A-2**  
**Microphone**

---



---

<b>Pin</b>	<b>Signal</b>	<b>Pin</b>	<b>Signal</b>
1	Audio in	2	Ground

---

---

**Table A-3**  
**Keyboard/Mouse**

---

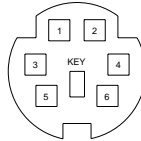

Pin	Signal	Pin	Signal
1	Keyboard/mouse data1	4	+5 VDC
2	Keyboard/mouse data2	5	Keyboard/mouse clock1
3	Ground	6	Keyboard/mouse clock2

---

---

**Table A-4**  
**RJ-11 Modem**

---

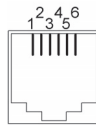

Pin	Signal	Pin	Signal
1	Unused	4	Unused
2	Tip	5	Unused
3	Ring	6	Unused

---

**Table A-5  
RJ-45 Network Interface**

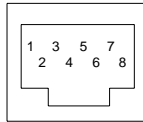

Pin	Signal	Pin	Signal
1	Transmit +	5	Unused
2	Transmit -	6	Receive -
3	Receive +	7	Unused
4	Unused	8	Unused

**Table A-6  
Universal Serial Bus**

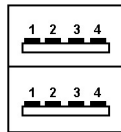

Pin	Signal	Pin	Signal
1	+5 VDC	3	Data +
2	Data -	4	Ground

---

**Table A-7**  
**Serial**

---

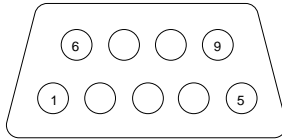

---

<b>Pin</b>	<b>Signal</b>	<b>Pin</b>	<b>Signal</b>
1	Carrier detect	6	Data set ready
2	Receive data	7	Ready to send
3	Transmit data	8	Clear to send
4	Data terminal ready	9	Ring indicator
5	Signal ground		

---

**Table A-8**  
**External Monitor**

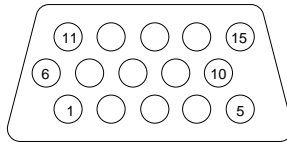

Pin	Signal	Pin	Signal
1	Red analog	9	+5 VDC
2	Green analog	10	Ground
3	Blue analog	11	Monitor detect
4	Not connected	12	DDC 2B data
5	Ground	13	Horizontal sync
6	Ground analog	14	Vertical sync
7	Ground analog	15	DDC2B clock
8	Ground analog		

**Table A-9**  
**Parallel**

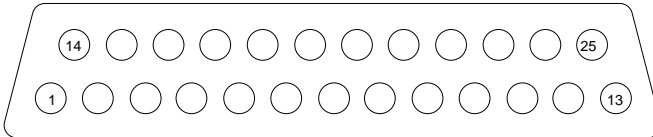

Pin	Signal	Pin	Signal
1	Strobe*	10	Acknowledge*
2	Data bit 0	11	Busy
3	Data bit 1	12	Paper out
4	Data bit 2	13	Select
5	Data bit 3	14	Auto line feed*
6	Data bit 4	15	Error*
7	Data bit 5	16	Initialize printer*
8	Data bit 6	17	Select in*
9	Data bit 7	18-25	Signal ground

\*Signal is active low.

---

## Power Cord Set Requirements

### 3-Conductor Power Cord Set

The wide range input features enable the computer to operate from any line voltage from 100 to 120 or 220 to 240 volts AC.

The power cord set received with the computer meets the requirements for use in the country where the equipment is purchased.

Power cord sets for use in other countries must meet the requirements of the country where the computer is used. For more information on power cord set requirements, contact a Compaq authorized reseller or service provider.

### General Requirements

The requirements listed below are applicable to all countries:

1. The length of the power cord set must be at least 5.00 feet (1.5 m) and a maximum of 6.50 feet (2.0 m).
2. All power cord sets must be approved by an acceptable accredited agency responsible for evaluation in the country where the power cord set will be used.

3. The power cord set must have a minimum current capacity of 10A and a nominal voltage rating of 125 or 250 volts AC, as required by each country's power system.
4. The appliance coupler must meet the mechanical configuration of an EN 60 320/IEC 320 Standard Sheet C13 connector, for mating with appliance inlet on the back of the computer.

## Country-Specific Requirements

---

### 3-Conductor Power Cord Set Requirements—By Country

---

Country	Accredited Agency	Applicable Note Number
Australia	EANSW	1
Austria	OVE	1
Belgium	CEBC	1
Canada	CSA	2
Denmark	DEMKO	1
Finland	FIMKO	1
France	UTE	1
Germany	VDE	1
Italy	IMQ	1
Japan	METI	3
The Netherlands	KEMA	1
Norway	NEMKO	1
Sweden	SEMKO	1
Switzerland	SEV	1
United Kingdom	BSI	1
United States	UL	2

---



## Notes



1. The flexible cord must be <HAR> Type HO5VV-F, 3-conductor, 1.0 mm<sup>2</sup> conductor size. Power cord set fittings (appliance coupler and wall plug) must bear the certification mark of the agency responsible for evaluation in the country where it will be used.
2. The flexible cord must be Type SPT-3 or equivalent, No. 18 AWG, 3-conductor. The wall plug must be a two-pole grounding type with a NEMA 5-15P (15A, 125V) or NEMA 6-15P (15A, 250V) configuration.
3. The appliance coupler, flexible cord, and wall plug must bear a “T” mark and registration number in accordance with the Japanese Dentori Law. The flexible cord must be Type VCT or VCTF, 3-conductor, 1.00mm<sup>2</sup> conductor size. The wall plug must be a two-pole grounding type with a Japanese Industrial Standard C8303 (7A, 125V) configuration.

# C

## Screw Listing

This appendix provides specification and reference information for the screws used in the computer. All screws listed in this appendix are available in the Miscellaneous Screw Kit, spare part number 233656-001.

**Table C-1**  
**M2.5 × 5 Screw**

 	Color	Qty	Length	Thread	Head Width
	Black	2	5 mm	M2.5	5.5 mm

**Where used:** 2 screws securing the keyboard to the base enclosure (documented in Section 5.7)



---

**Table C-2**  
**M2.5 × 4.5 Screw**

---

	Color	Qty	Length	Thread	Head Width
	Black	15	4.5 mm	M2.5	4 mm



---

**Where used:** 2 screws securing the hinge covers to the display hinges (documented in Section 5.6).

---

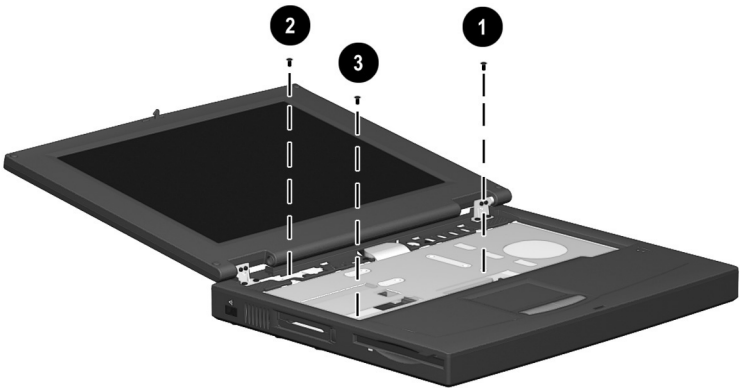

**Table C-2**  
**M2.5 × 4.5 Screw (Continued)**



 	Color	Qty	Length	Thread	Head Width
	Black	15	4.5 mm	M2.5	4 mm

**Where used:**

- 1 screw securing the optical drive to the heat sink (documented in Section 5.8)
- 1 screw securing the display ground cable to the base enclosure (documented in Section 5.9)
- 1 screw securing the heat sink to the base enclosure (documented in Section 5.10)

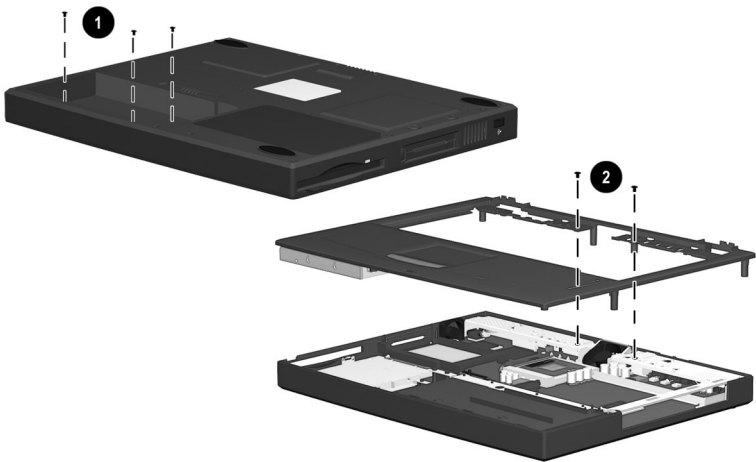

**Table C-2**  
**M2.5 x 4.5 Screw (Continued)**



		Color	Qty	Length	Thread	Head Width
		Black	15	4.5 mm	M2.5	4 mm

**Where used:**

- ❶ 3 screws securing the top cover to the base enclosure through the battery bay (documented in Section 5.11)
- ❷ 2 screws securing the top cover to the base enclosure through the top (documented in Section 5.11)

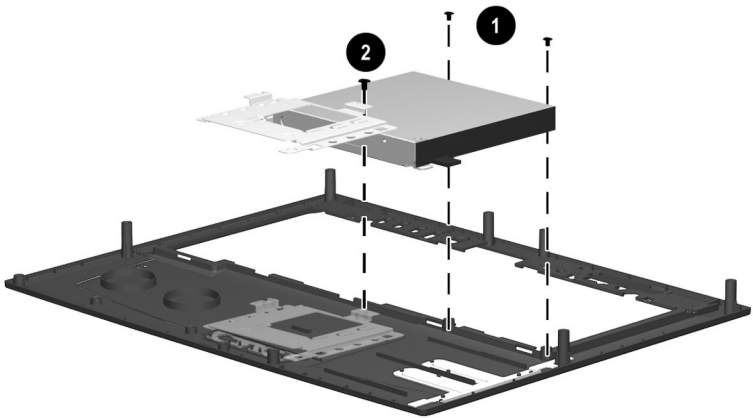

**Table C-2**  
**M2.5 × 4.5 Screw (Continued)**

 	Color	Qty	Length	Thread	Head Width
	Black	15	4.5 mm	M2.5	4 mm

**Where used:**

- ❶ 2 screws securing the diskette drive to the top cover (documented in Section 5.12)
- ❷ 1 screw securing the TouchPad to the top cover (documented in Section 5.13)



---

**Table C-2**  
**M2.5 x 4.5 Screw (Continued)**

---

	Color	Qty	Length	Thread	Head Width
	Black	15	4.5 mm	M2.5	4 mm

---

**Where used:** 2 screws securing the fan and fan bracket to the base enclosure (documented in Section 5.16)

---

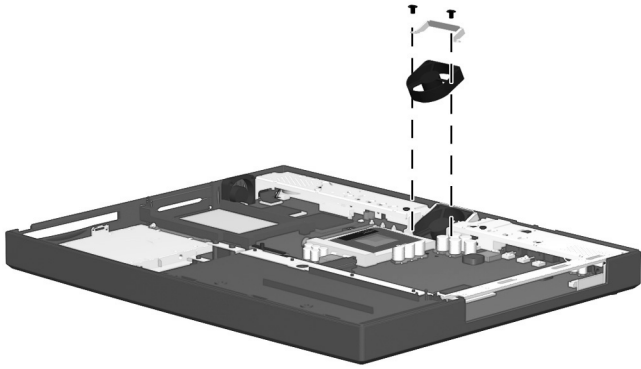
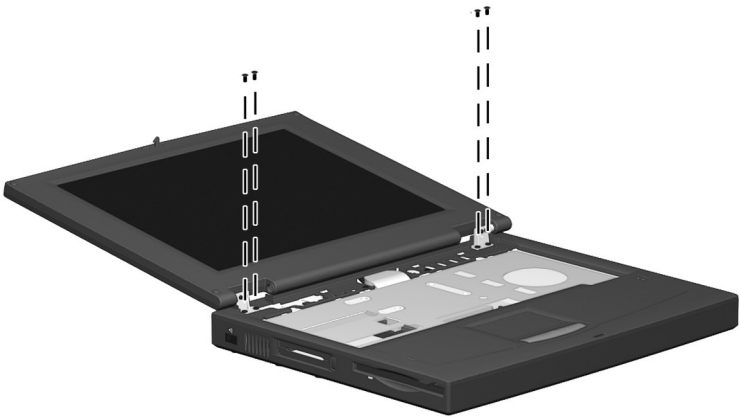

**Table C-3**  
**M2.5 × 7 Screw**

	Color	Qty	Length	Thread	Head Width
	Black	25	7 mm	M2.5	4.5 mm

**Where used:**

- 1 screw securing the modem/network interface card compartment cover to the base enclosure (refer to the *Hardware Guide* included with the computer for installation procedure)
- 2 screws securing the memory expansion compartment cover to the base enclosure (refer to the *Hardware Guide* included with the computer for installation procedure)
- 4 screws securing the display to the base enclosure (illustrated below; documented in Section 5.9)



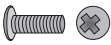
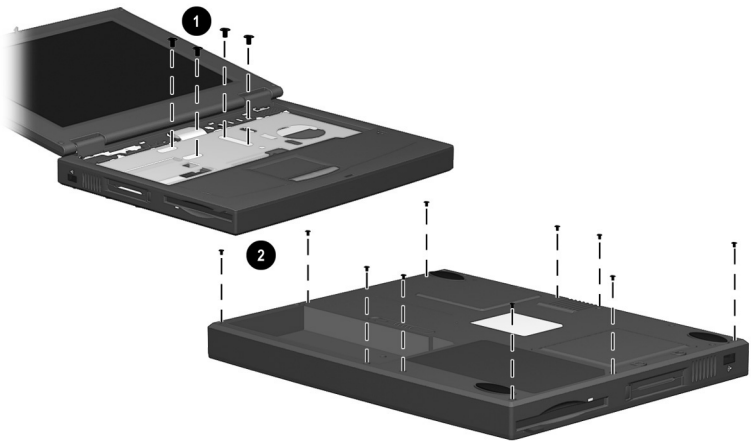

**Table C-3**  
**M2.5 x 7 Screw (Continued)**

	Color	Qty	Length	Thread	Head Width
	Black	25	7 mm	M2.5	4.5 mm

**Where used:**

- ❶ 4 screws securing the heat sink to the base assembly (documented in Section 5.10)
- ❷ 10 screws securing the top cover to the base enclosure through the bottom of the computer (documented in Section 5.11)

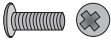

**Table C-3**  
**M2.5 x 7 Screw (Continued)**

	Color	Qty	Length	Thread	Head Width
	Black	25	7 mm	M2.5	4.5 mm

**Where used:** 4 screws securing the system board to the base enclosure through the computer bottom (documented in Section 5.17)

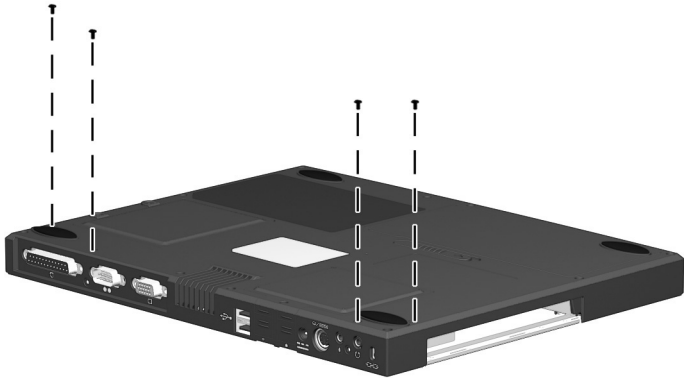

**Table C-4**  
**M2.5 x 5.5 Screw**

---

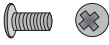
	Color	Qty	Length	Thread	Head Width
	Black	6	5.5 mm	M2.5	4.5 mm

---

**Where used:**

- ❶ 3 screws securing the hard drive and hard drive bracket to the base enclosure (documented in Section 5.14)
  - ❷ 1 screw securing the optical drive alignment rail to the base enclosure (documented in Section 5.17)
  - ❸ 2 screws securing the system board to the base enclosure (documented in Section 5.17)
- 

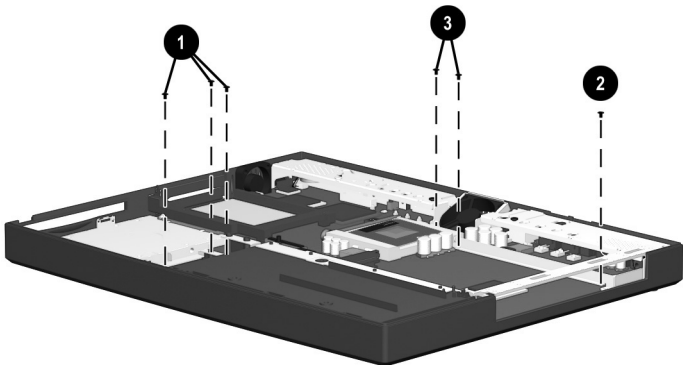

---

# Index

## A

### AC adapter

- spare part numbers 3–13
- specifications 6–10

## B

### base enclosure

- illustrated 3–4, 3–6
- spare part number 3–7

### battery

- illustrated 3–4, 3–6
- light 1–17
- release latch 1–19
- spare part number 3–7
- specifications 6–11

## C

### Cable Kit

- components 3–10
- spare part number 3–10

### cables 4–2

### caps lock

- key 1–15
- light 1–17

### CD-ROM drive

- alignment rail 5–41
  - illustrated 3–9
- illustrated 3–4, 3–6, 3–11
- removal 5–12

- spare part number 3–7, 5–12

- specifications 6–8

### Certificate of Authenticity

- label 1–19

### computer

- bottom components 1–19
- display components 1–11
- features 1–6
- feet
  - illustrated 3–8
  - locations 5–5
- keyboard components 1–15
- left side components 1–11
- models 1–2
- rear panel components 1–12
- right side components 1–12
- specifications 6–1
- top components 1–16

### connector pin assignments

#### A–1

- headphone jack A–1
- keyboard connector A–2
- microphone jack A–1
- modem jack A–2
- monitor connector A–5
- mouse connector A–2

- network interface jack A-3
- parallel connector A-6
- RJ-11 jack A-2
- RJ-45 jack A-3
- serial connector A-4
- speaker jack A-1
- universal serial bus (USB) connector A-3
- connectors 4-2
- cursor control keys 1-15
- D**
- design overview 1-20
- disassembly sequence chart 5-3
- disk cell battery
  - removal 5-34
  - spare part number 3-5, 5-34
- diskette drive 1-11
  - cable
    - illustrated 3-10
    - removal 5-26
  - illustrated 3-2, 3-11
  - removal 5-27
  - spare part number 3-5, 5-27
  - specifications 6-7
- display
  - ground cable 5-16
  - illustrated 3-2
  - installation 5-17
  - release latch 1-11
  - removal 5-14
  - spare part number 3-3, 5-14
  - specifications 6-3, 6-4
  - switch 1-15
  - video cable 5-16
- DMA specifications 6-12
- drives, preventing damage 4-2
- DVD-ROM drive
  - alignment rail 5-41
    - illustrated 3-9
  - illustrated 3-4, 3-6, 3-11
  - removal 5-12
  - spare part number 3-7, 5-12
  - specifications 6-9
- E**
- Easy Access buttons 1-17
- electrostatic
  - damage, preventing 4-4
  - voltage levels 4-7
- embedded numeric keypad 1-15
- F**
- F1 through F12 keys 1-15
- fan
  - bracket 5-37
    - illustrated 3-9
  - installation 5-38
  - removal 5-36
  - spare part number 3-5, 5-36
  - vent 1-19
- Fn key 1-15
- front label area 1-19

**G**

- grounding
  - equipment 4–6
  - methods 4–6

**H**

- hard drive
  - bracket
    - illustrated 3–9
    - removal 5–33
  - illustrated 3–11
  - light 1–16
  - removal 5–32
  - spare part number 3–5, 3–11, 5–32
  - specifications 6–5

**Hardware Kit**

- components 3–5, 3–9
- spare part number 3–5, 3–9

- headphone jack 1–12
  - pin assignments A–1

**heat sink**

- illustrated 3–2
- removal 5–18
- spare part number 3–5, 5–18

**hinge covers**

- illustrated 3–8
- removal 5–15

**I**

- I/O address specifications 6–14
- illustrated parts catalog 3–1
- infrared
  - port 1–11
- interrupt specifications 6–13

**K****keyboard**

- components 1–14
- connector 1–13
  - pin assignments A–2
- illustrated 3–2
- removal 5–9
- spare part number 3–3, 5–9

**L****LED cover**

- illustrated 3–2
- removal 5–8
- spare part number 3–3, 5–8

- Logo Kit spare part number 3–13

**M****mass storage devices**

- illustrated 3–11
- spare part numbers 3–11

**memory**

- expansion board, spare part numbers 3–13
- expansion compartment 1–19
- expansion slot cover, illustrated 3–8

- memory map specifications 6–17

**microphone 1–17**

- cable
  - disconnecting 5–41
  - routing 5–43

- jack 1–12
  - pin assignments A–1

- Microsoft logo key 1–15

- mini PCI slot cover 1–19
  - illustrated 3–8
- modem
  - adapter, spare part numbers 3–12
  - cable adapter, spare part numbers 3–12
  - cable, spare part number 3–12
  - jack, pin assignments A–2
  - removal 5–6
  - spare part number 3–12, 5–6
- monitor connector 1–13
  - pin assignments A–5
- mouse connector 1–13
  - pin assignments A–2
- N**
- network interface card (NIC)
  - removal 5–6
  - spare part number 3–12, 5–6
- network interface jack
  - pin assignments A–3
- num lock light 1–17
- O**
- optical drive 1–12
  - alignment rail 5–41
    - illustrated 3–9
  - illustrated 3–4, 3–6
  - removal 5–12
  - spare part number 3–7, 5–12
  - specifications 6–8, 6–9

- P**
- packing precautions 4–4
- parallel connector 1–13
  - pin assignments A–6
- PC Card
  - eject button 1–11
  - slot 1–11
- plastic parts 4–2
- Plastics Kit
  - components 3–3, 3–8
  - illustrated 3–2
  - spare part number 3–3, 3–8
- power
  - button 1–17
  - cord
    - 3-conductor set B–1
    - country-specific requirements B–2
    - general requirements B–1
    - notes B–3
    - set requirements B–1
    - spare part numbers 3–13
  - jack 1–13
- Power Management 1–9
- preparing the computer for disassembly 5–4
- processor
  - spare part number 3–7
- R**
- removal
  - preliminaries 4–1
  - procedures 5–1

- replacement
  - preliminaries 4-1
  - procedures 5-1
- RJ-11
  - cable, illustrated 3-10
  - cover, illustrated 3-8
  - jack 1-13
    - pin assignments A-2
  - P55 adapter spare part numbers 3-12
  - PTT adapter spare part number 3-12
- RJ-45
  - cable, illustrated 3-10
  - cover, illustrated 3-8
  - jack 1-13
    - pin assignments A-3
  - network cable
    - spare part number 3-12
- RTC battery
  - removal 5-34
  - spare part number 3-5, 5-34
- S**
- Screw Kit
  - components C-1
  - spare part number 3-13
- screw listing C-1
- scroll lock light 1-17
- security cable slot 1-12
- serial connector 1-13
  - pin assignments A-4
- serial number location 1-19, 3-1, 5-2
- service considerations 4-1
- speaker jack 1-12
  - pin assignments A-1
- speakers 1-16
- specifications
  - AC adapter 6-10
  - battery 6-11
  - CD-ROM drive 6-8
  - computer 6-1
  - diskette drive 6-7
  - display 6-3, 6-4
  - DMA 6-12
  - DVD-ROM drive 6-9
  - hard drive 6-5
  - I/O addresses 6-14
  - interrupts 6-13
  - memory map 6-17
  - optical drive 6-8, 6-9
- static shielding materials 4-7
- system board
  - illustrated 3-4, 3-6
  - removal 5-39
  - spare part number 3-7, 5-39
- T**
- tools required 4-1
- top cover
  - illustrated 3-2
  - removal 5-24
  - spare part number 3-5, 5-24



TouchPad 1–17  
  bracket 5–30  
  buttons 1–17  
  cable  
    illustrated 3–10  
    removal 5–26  
  illustrated 3–2  
  removal 5–29  
  spare part number 3–5,  
    5–29  
  transporting precautions 4–4  
  troubleshooting 2–1

## **U**

universal serial bus (USB)  
  connector 1–13  
  pin assignments A–3

## **V**

vent 1–11, 1–13

## **W**

Windows application key  
  1–15  
  workstation precautions 4–5